



McGill

ciena

HL HYPERLIGHT

KEYSIGHT  
TECHNOLOGIES

# Enabling 3.2 Tbps Interconnects: Technologies and Architectures for 448 Gbps PAM4 link

**Charles St-Arnault**<sup>1</sup>, Santiago Bernal<sup>1</sup>, Derek Kita<sup>3</sup>, Ross Dickson<sup>2</sup>, Mariam Yehia Abdelaziz<sup>1</sup>, Aleksandar Nikic<sup>1</sup>, Benton Qiu<sup>1</sup>, Benjamin Krueger<sup>4</sup>, Fabio Pittalà<sup>4</sup>, Christian Reimer<sup>3</sup>, Bruce Beggs<sup>2</sup>, Naim Ben-Hamida<sup>2</sup>, and David V. Plant<sup>1</sup>

<sup>1</sup> McGill University, Montreal, Canada

<sup>2</sup> Ciena Corporation, Ottawa, Canada

<sup>3</sup> HyperLight Corporation, Cambridge, USA

<sup>4</sup> Keysight Technologies, Böblingen, Germany



ECOC2025

# Presentation Plan

1. Challenges in achieving 448 Gbps/lane
2. Single Wavelength Setup & Results
  - a. Empirical Rx Equalizer Comparison
3. 8-WDM Setup & Results
  - a. Net 3.2 Tbps at 2 (PAM4) and 5 (PAM8) km
4. DR8 Setup & Results
  - a. Net 3.2 Tbps at 500 m and 2 km (DR8 and DR8+)
5. Conclusion
6. **Bonus Results**



# Challenges in achieving 448 Gbps/lane

- Device Limitations

1. Modulator bandwidth and  $V_{\pi}$
2. DAC Bandwidth (bottleneck)

- System Limitations

1. System bandwidth limitations → Inter Symbol Interference (ISI)
2. Colored noise spectrum → Frequency dependent SNR

- Which receiver equalizer is best for this situation?

- We empirically compare:
  - FFE
  - DFE
  - 1-tap MLSE

# Device Limitations - DAC

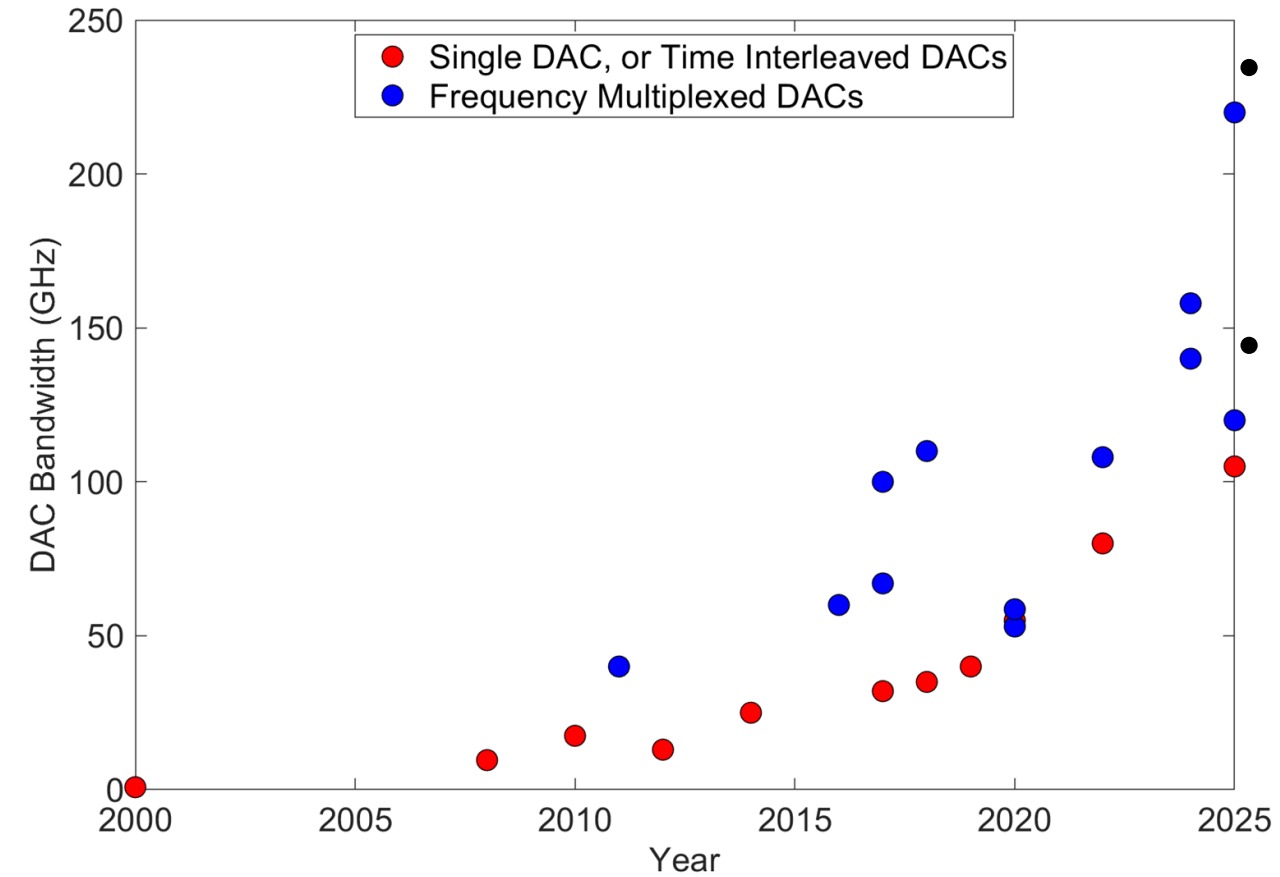

- Literature and commercial product survey from 2000 to now.
- DAC Bandwidth increase:
  - DAC BW : +15 %/year
  - Freq. Multiplexed DAC BW : +11 %/year

# Device Limitations - Modulator

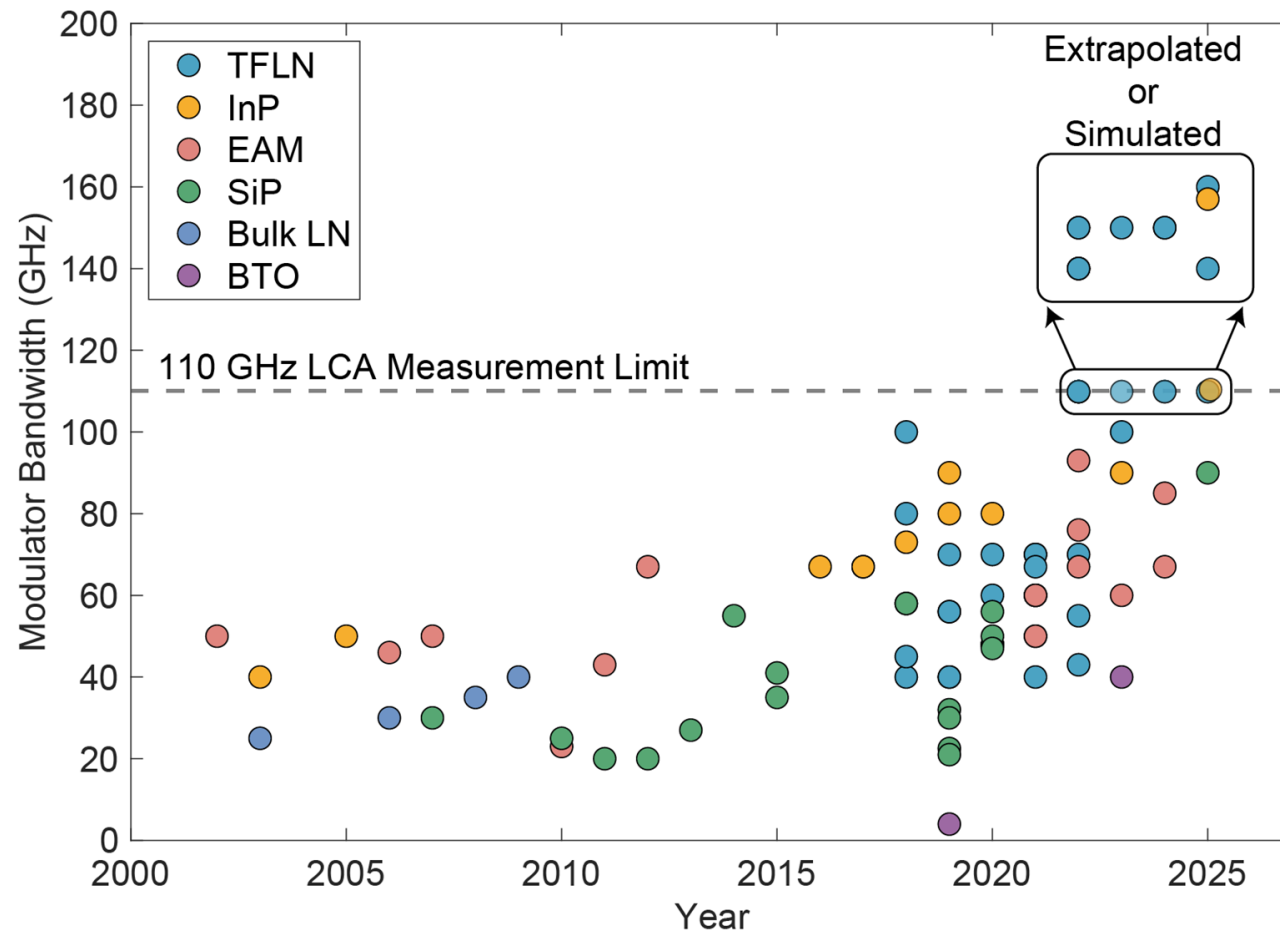

- Literature and commercial product survey from 2000 to now.
- Modulator Bandwidth increase:
  - TFLN : +19 %/year
  - InP : +7 %/year
  - EAM : +3 %/year
  - SiP : +8 %/year
  - BTO : not enough data for curve fit

\*No device was measured and published beyond 110 GHz. Slow E/O S21 rolloffs make for usable BW far beyond 110 GHz.

# The DAC Bottleneck

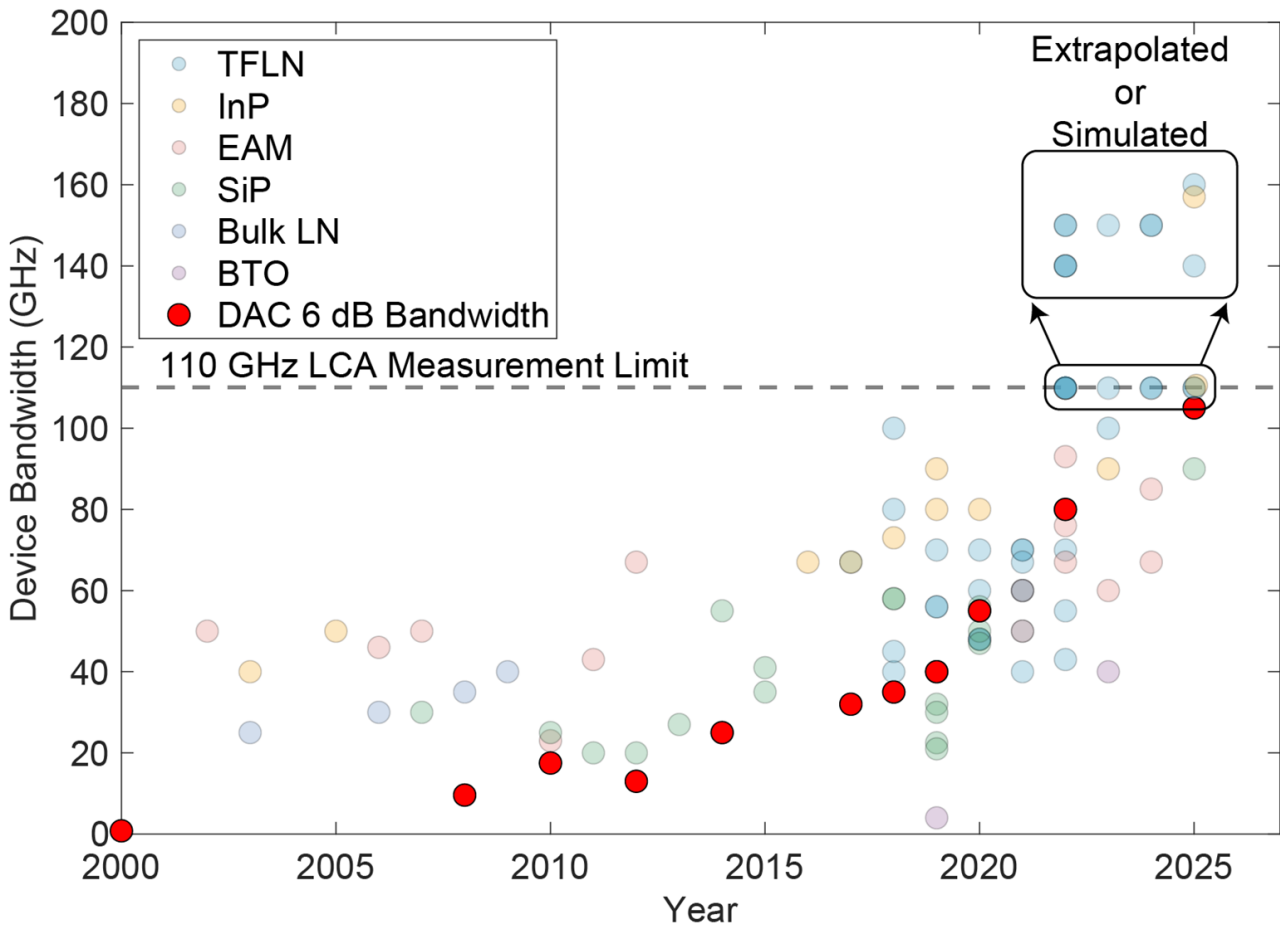

- Modulator bandwidth has already surpassed the DAC bandwidth
- TFLN MZM BW : +19 %/year
- DAC BW : +15 %/year

# System Level limitations

1. System bandwidth limitations □ Inter Symbol Interference (ISI)
    - From combined component bandwidth limitations
  2. Colored noise spectrum □ Frequency dependent SNR
- 100G and 200G / lane standardization raised many issues and concerns
  - Which receiver equalizer is best for this situation?
    - We theoretically and empirically compare:
      - FFE
      - DFE
      - MLSE

# Feed-Forward Equalizer (FFE)

- Linear filtering, lowest complexity
- Cannot discriminate between noise and signal
  - Colors noise spectrum -> SNR depends heavily on the frequency
- Ineffective in high-ISI channels, such as FTN transmission

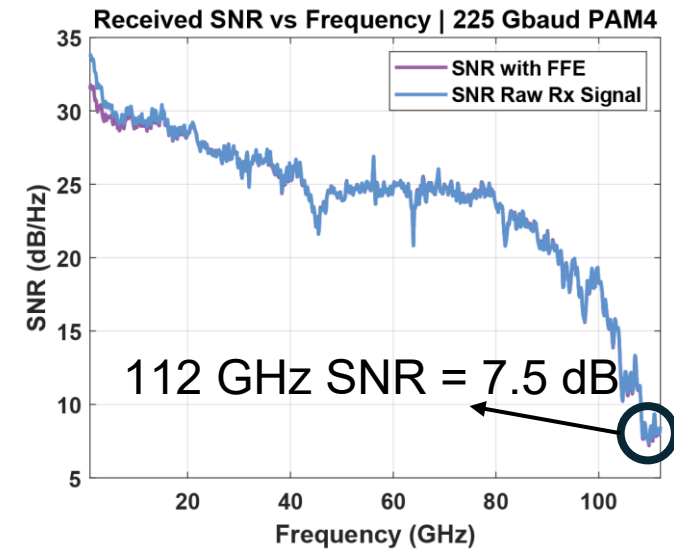
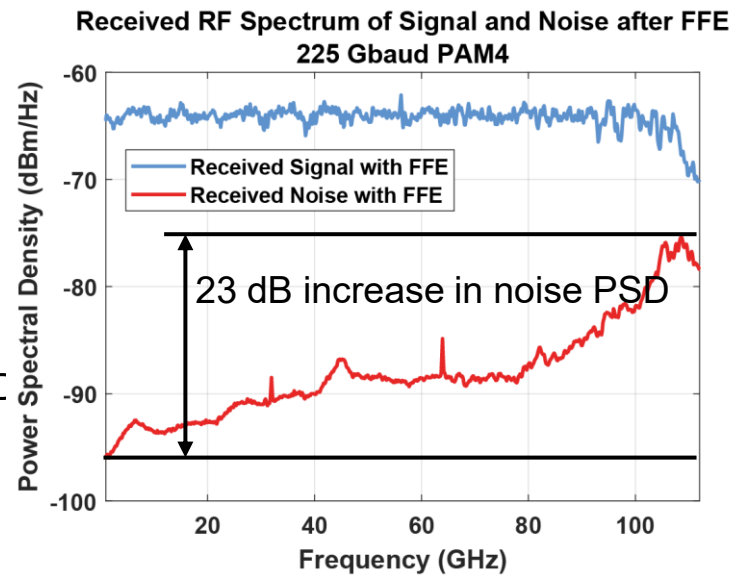
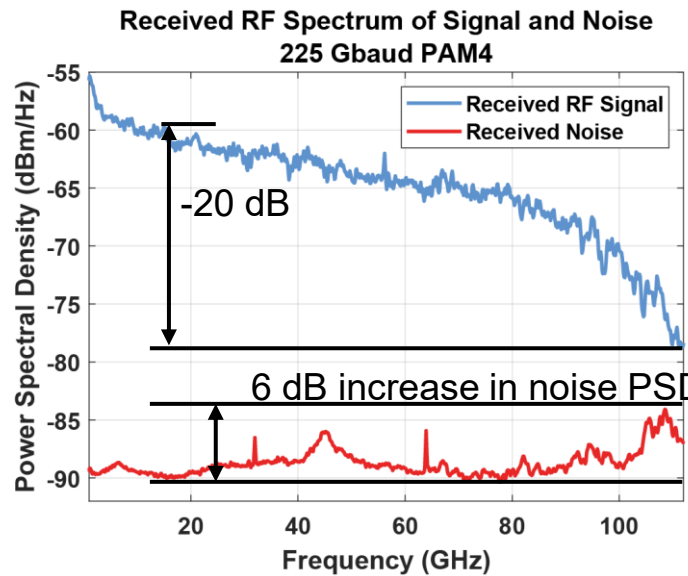
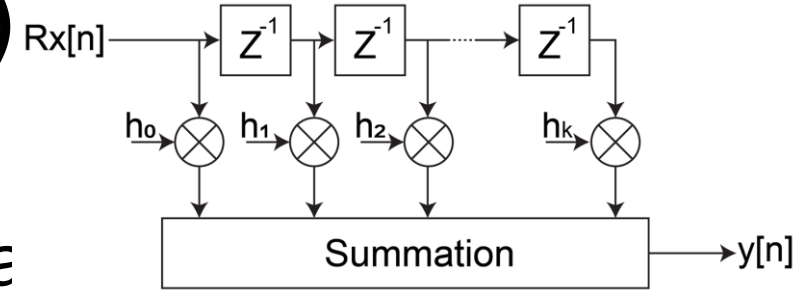

# Decision-Feedback Equalizer (DFE)

- Combats ISI without noise enhancement
  - Uses past-decisions instead of linear channel response inversion
- Wrong decisions spread into the feedback path increasing ISI
  - Error propagation
- The decision block can be integrated with a MLSE block
  - Reduced error propagation

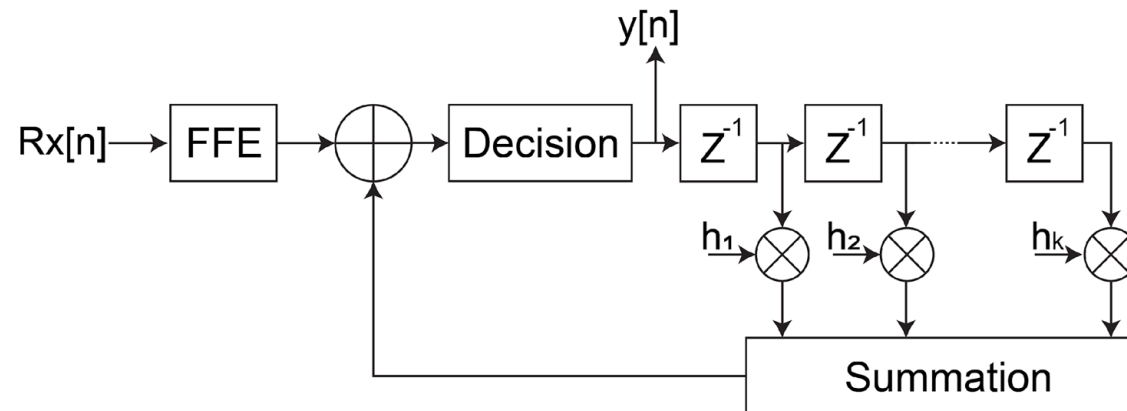

# Maximum Likelihood Sequence Estimation (MLSE) & Maximum a Posteriori Probability (MAP)

	MLSE	MAP
<b>Complexity</b>		
<b>Performance</b>	High ISI mitigation	High ISI mitigation
<b>Output</b>	Hard Decision output	Soft Decision output • LLR output

$|\chi|$  is the alphabet size (e.g., 4 for PAM4)

$L$  the channel memory length

# Cascaded Equalizers

- Use of FFE+DFE before the MLSE block
  - Drastically shortens the channel response
  - Simplifies MLSE complexity
    - Without FFE+DFE : effective channel response length  $\sim 20$  taps
      - $4^{20} \approx 1e+12$  complexity...
    - With FFE+DFE, only the main tap needs to be equalized
      - $4^1 = 4$  complexity

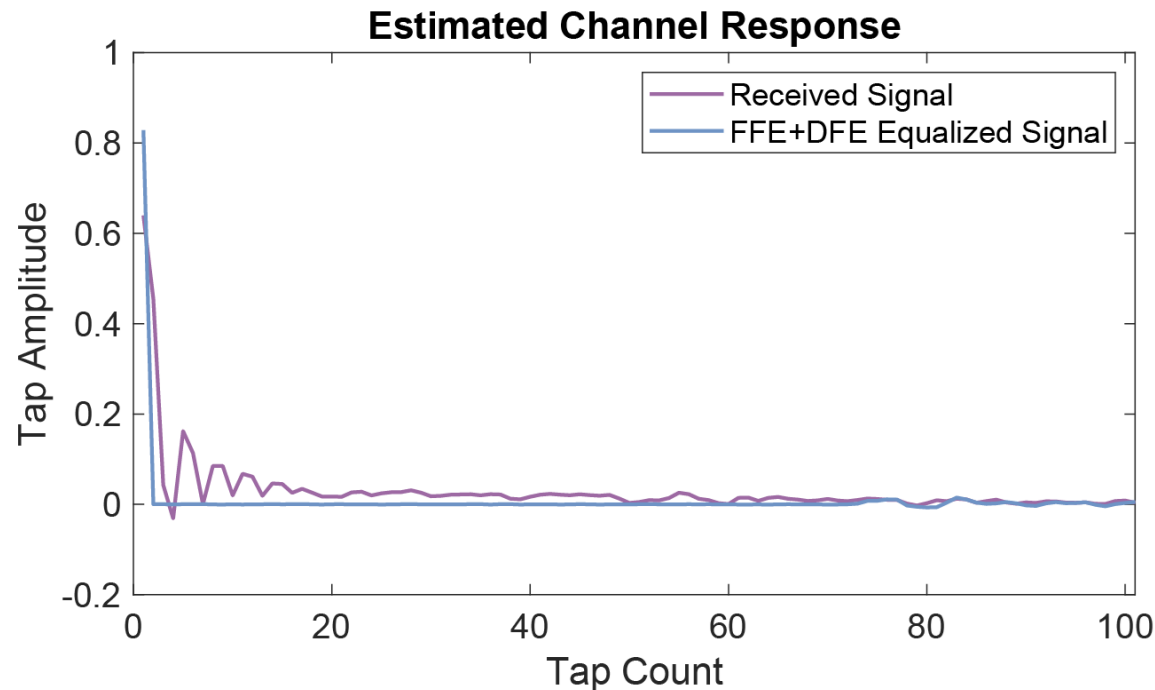

# WDM vs Parallel Single Mode Fiber

- FR8 (WDM):
  - Chromatic Dispersion
    - Increasingly tight WDM grids
    - Higher mux loss
  - Receiver demux required
  - Single fiber (LR standard - 10 km)

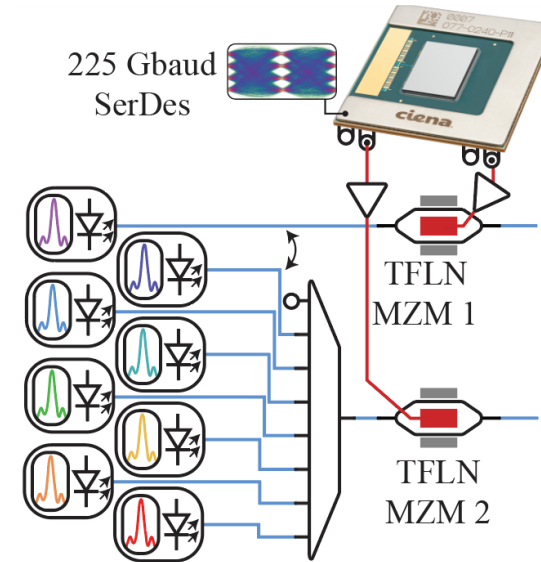

- DR8 (Parallel SMF)
  - Need 8 fibers
    - More costly for longer distances (e.g., 10 km)
  - Single or dual laser operation for 8 lanes
    - Reliability & power consumption improvements
    - Uncooled operation

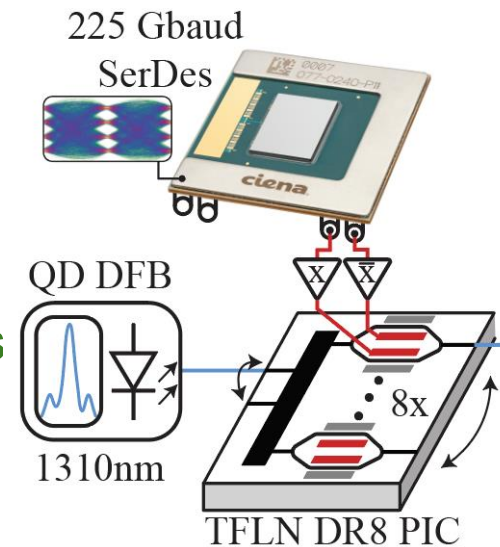

# Single Wavelength Experimental Setup

3 nm SerDes DAC Freq. Response

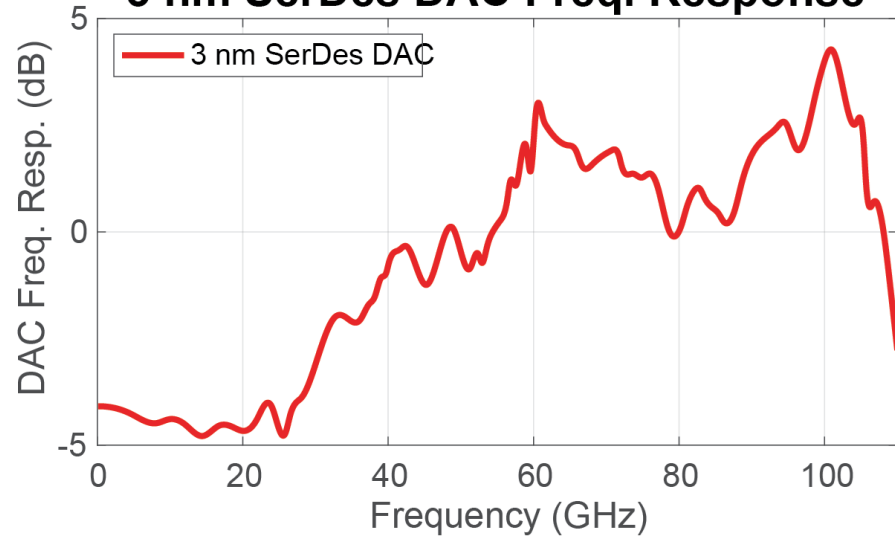

TFLN MZM E-O S21

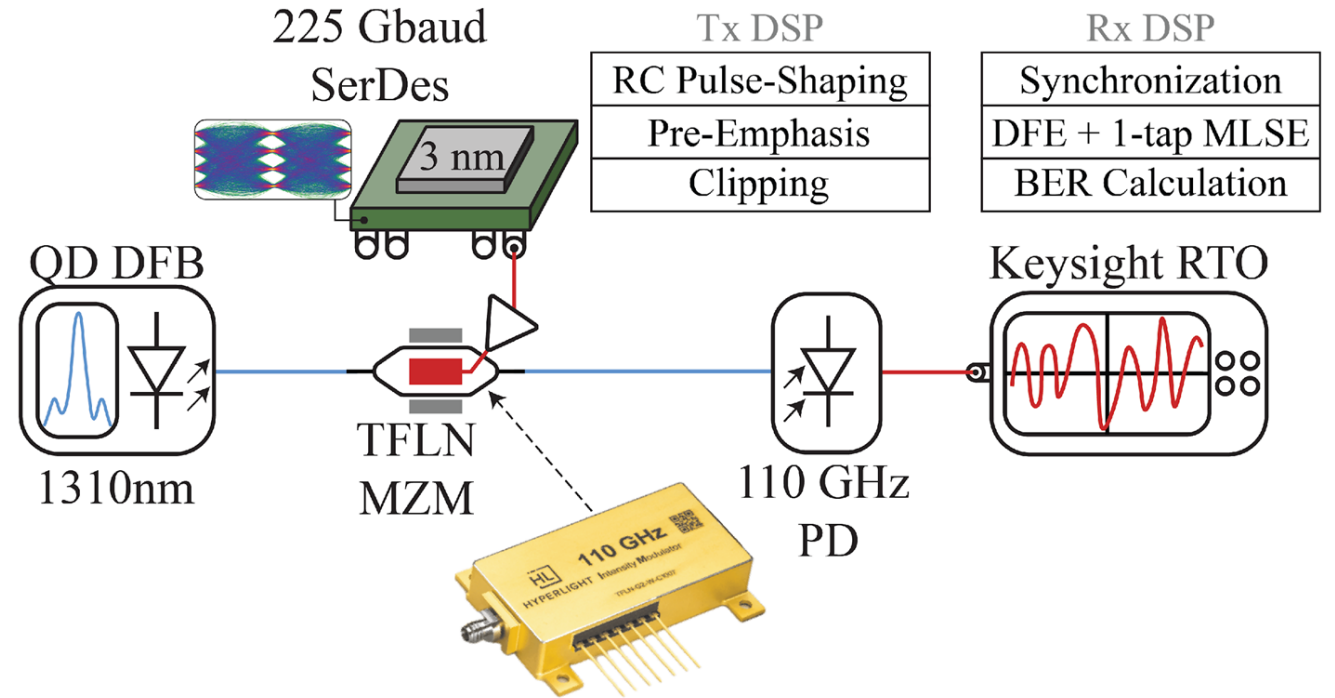
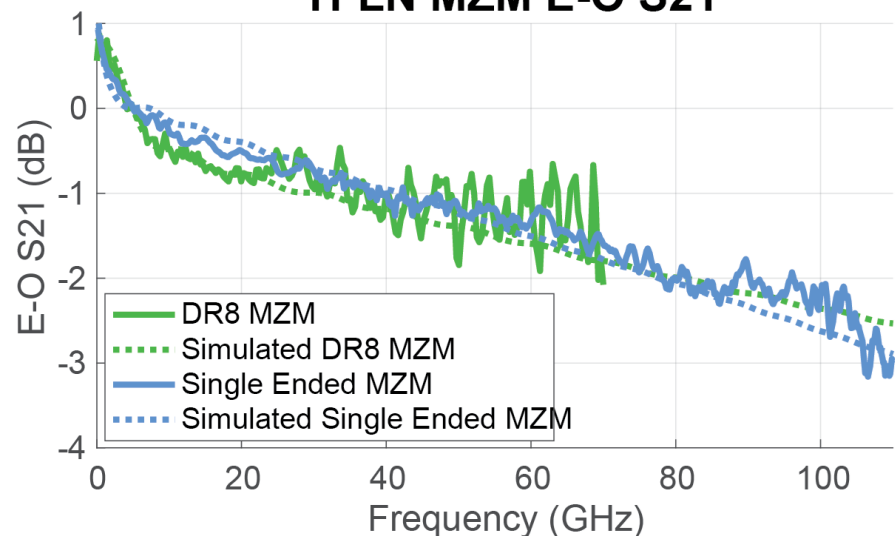

- Packaged TFLN 3 dB S21 > 110 GHz
- 3 nm DAC 6 dB bandwidth > 110 GHz

# Transmission Setup Performance

PAM-4 | 225 Gbaud

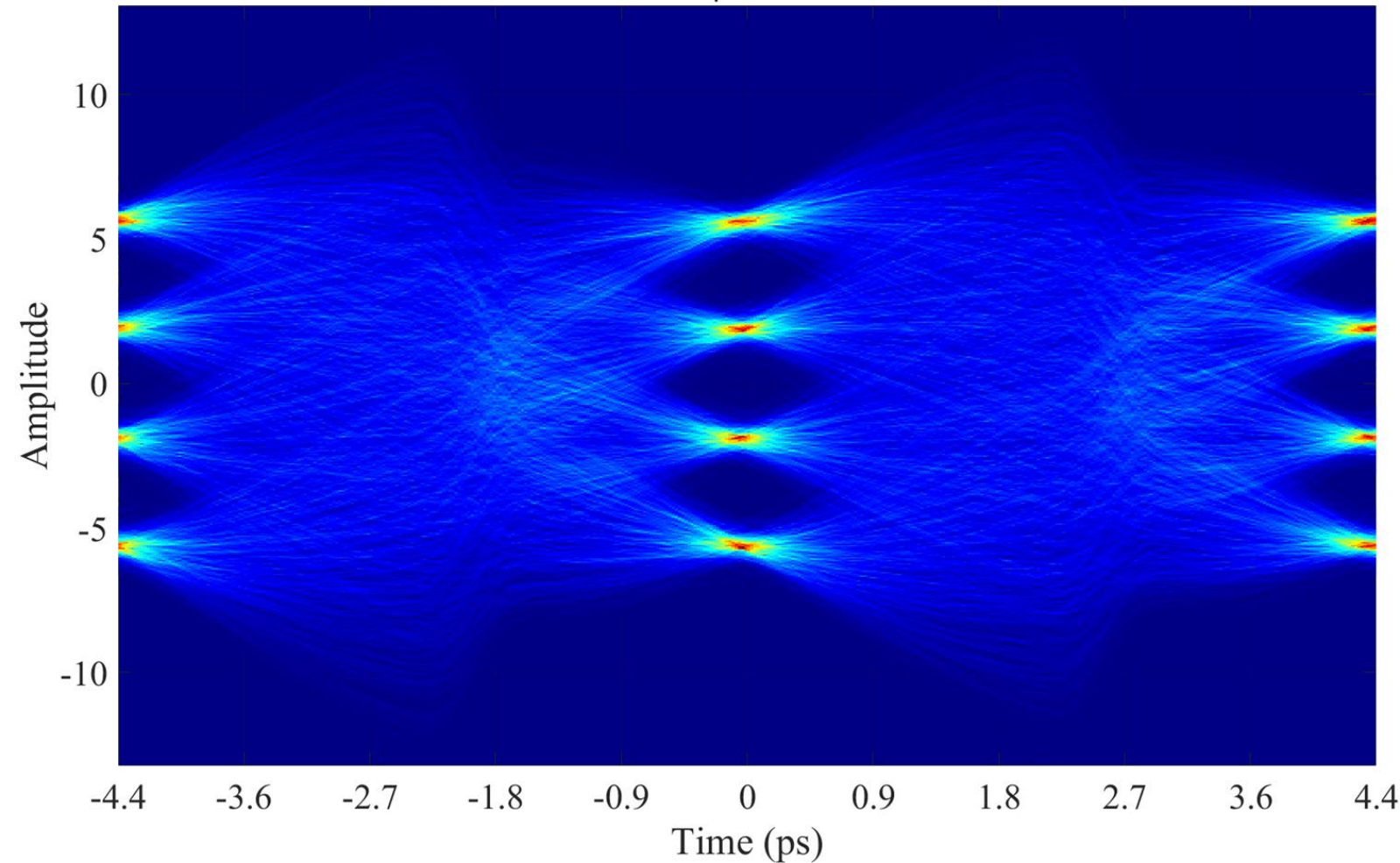

Pre-FEC BER = 2.1E-04  
 Net Rate = 420.5 Gbps (HD-FEC)

- Tx DSP
  - RC Pulse-shaping
    - Rolloff = 0.01
  - 21-tap pre-emphasis
  - Clipping
    - Tx PAPR = 3.2 dB
- Rx DSP
  - 4<sup>th</sup> order BT filter
    - $F_c = BR/2$
  - 41 FFE - 3 DFE
    - T-spaced
  - No averaging

# Rx DSP Comparison – Single Wavelength

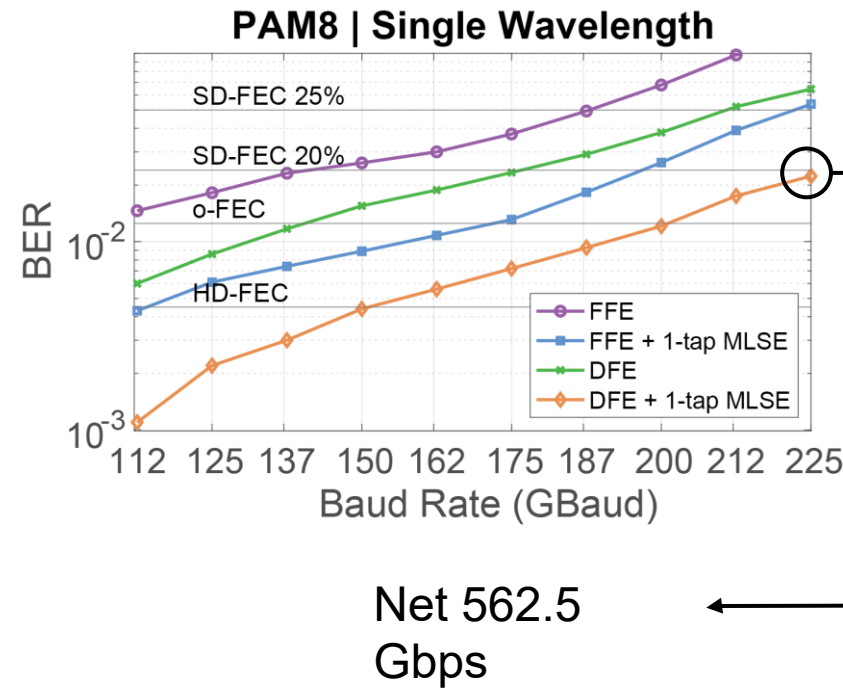
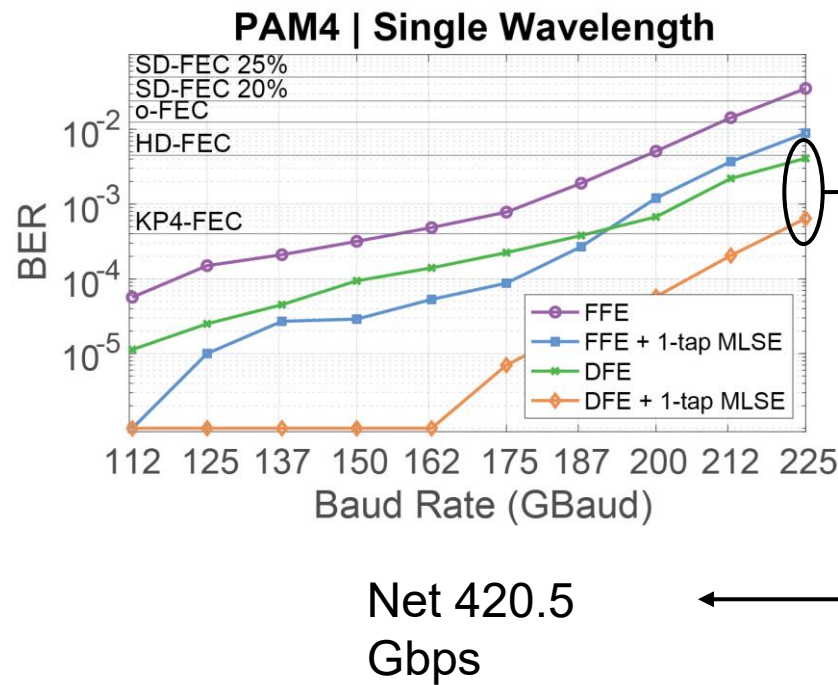

225 Gbaud PAM4 Receiver Eq. comparison:

- FFE vs DFE : 8.6x BER (compared to FFE)
- Adding 1-tap MLSE to FFE : 4.0x BER reduction (compared to standalone FFE)
- Adding 1-tap MLSE to DFE : 6.3x BER reduction (compared to standalone DFE)

# Rx DSP Comparison – Single Wavelength

## Received Optical Power Sensitivity Improvement

Receiver EQ	ROP Sensitivity Improvement (dB)
FFE + 1-tap MLSE vs FFE <sup>1</sup>	5.5
DFE vs FFE + 1-tap MLSE <sup>2</sup>	1.5
DFE + 1-tap MLSE vs DFE <sup>3</sup>	3.0

<sup>1</sup> At 25% SD-FEC

<sup>2</sup> At o-FEC

<sup>3</sup> At HD-FEC

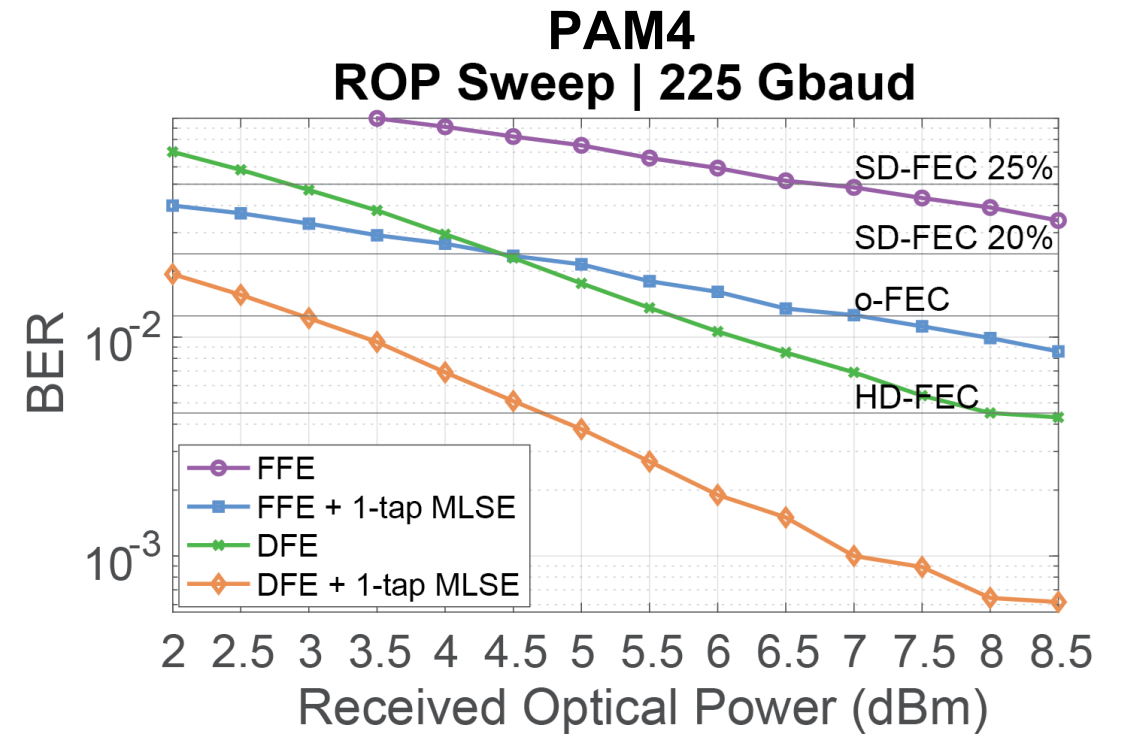

# 8-WDM Experimental Setup

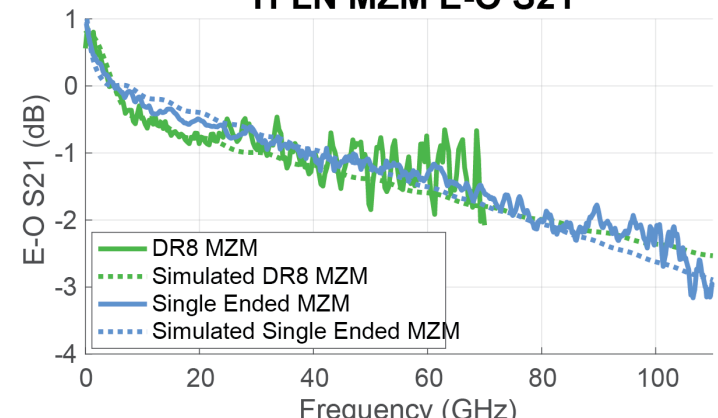
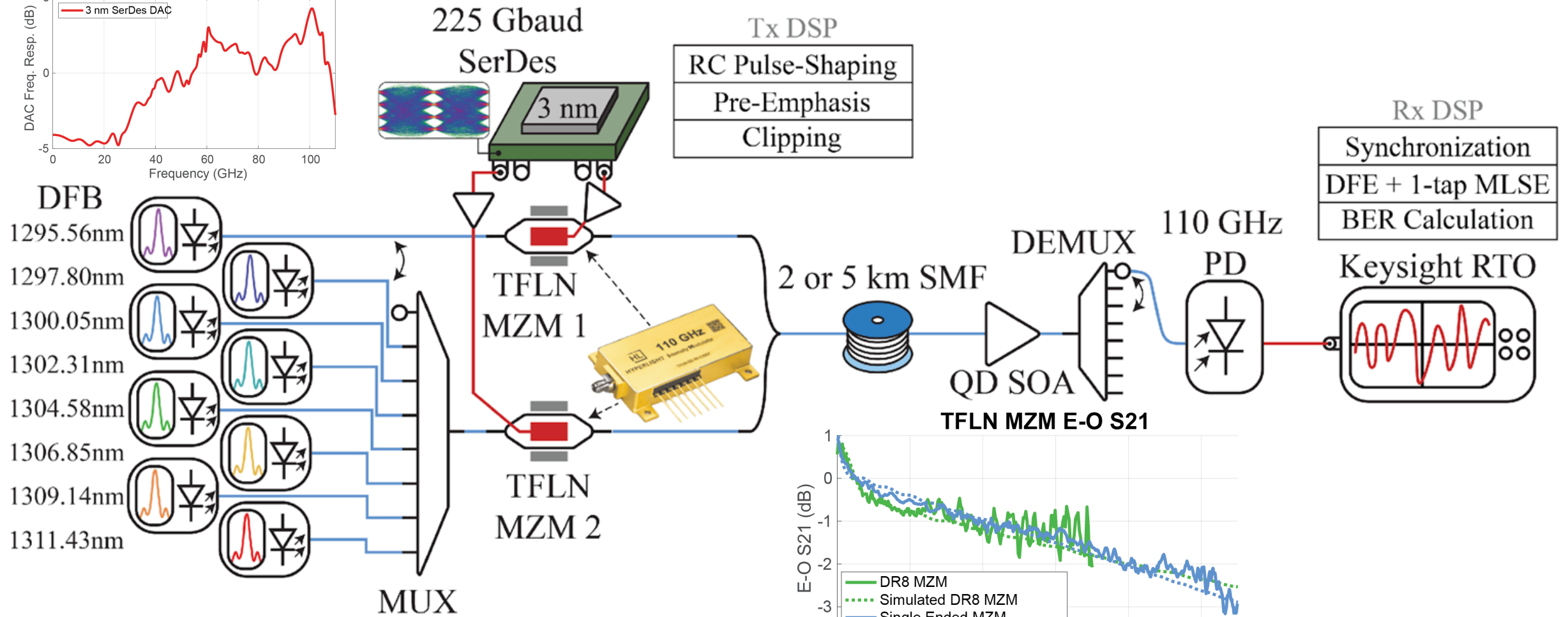
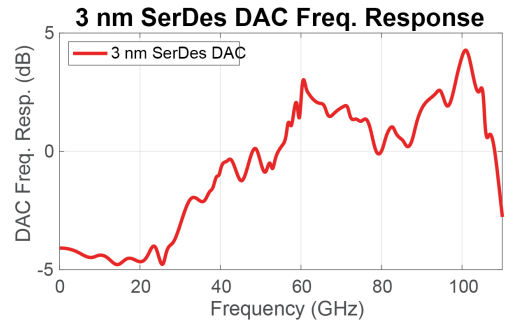

# PAM4(8) 2 km - 8WDM Results

## PAM4 | 8-WDM | 2 km

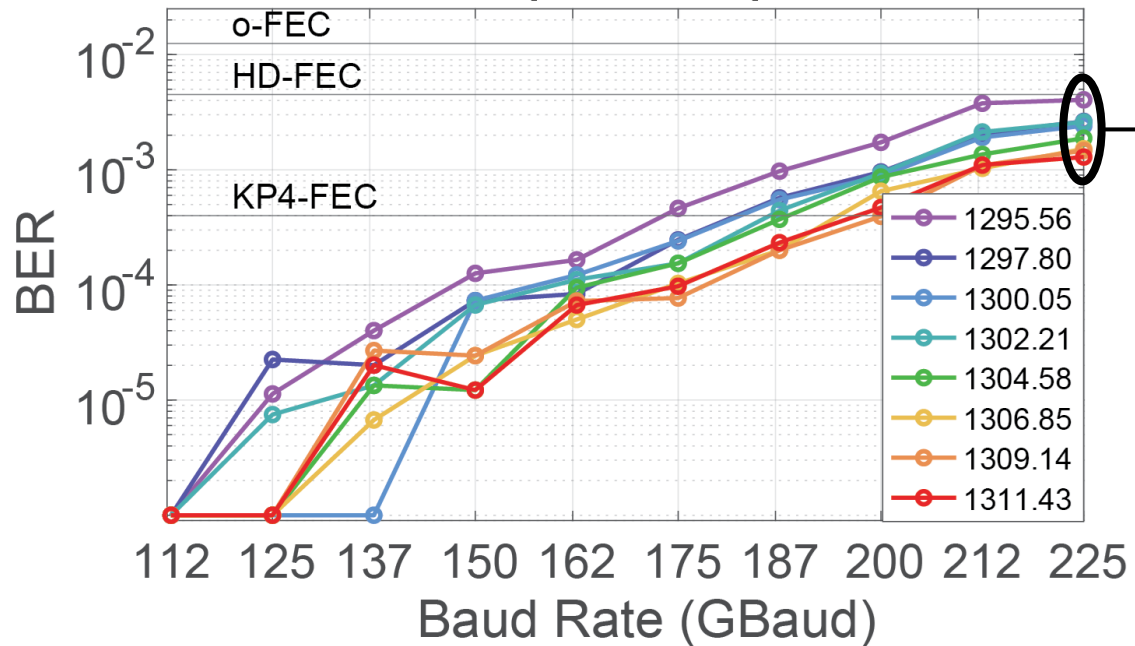

**3.2 Tbps**

8 x Net 420.5 Gbps

Net 3.2 Tbps  
(HD-FEC)

## PAM8 | 8-WDM | 2 km

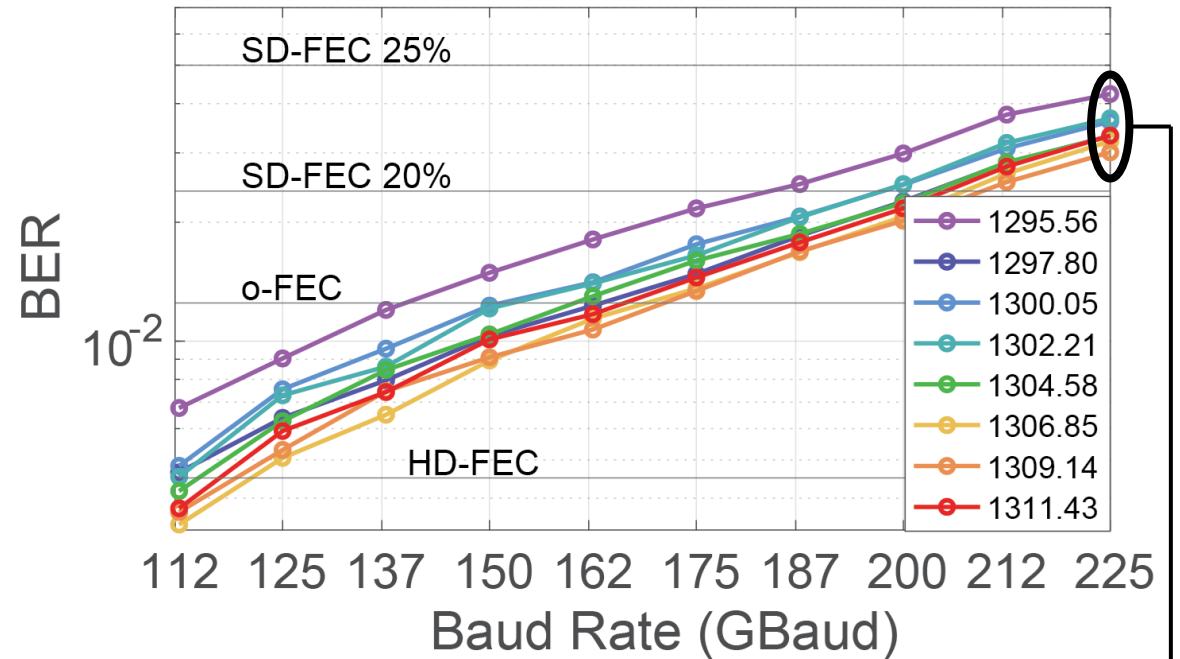

**4.2 Tbps**

8 x Net 540 Gbps

Net 4.32 Tbps  
(25% SD-FEC)

# PAM4(8) 5 km - 8WDM Results

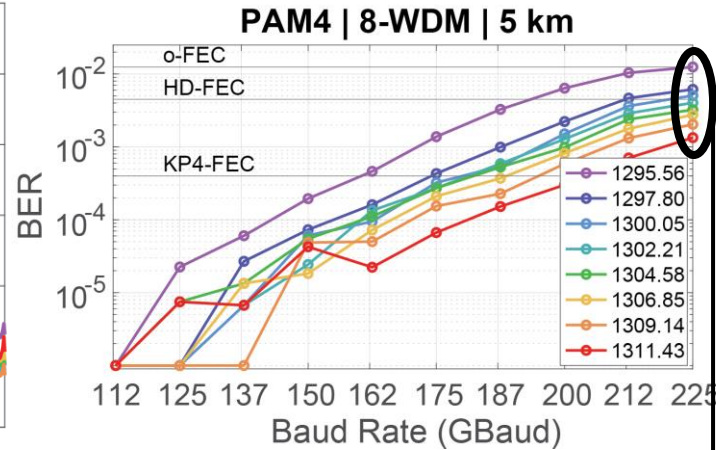
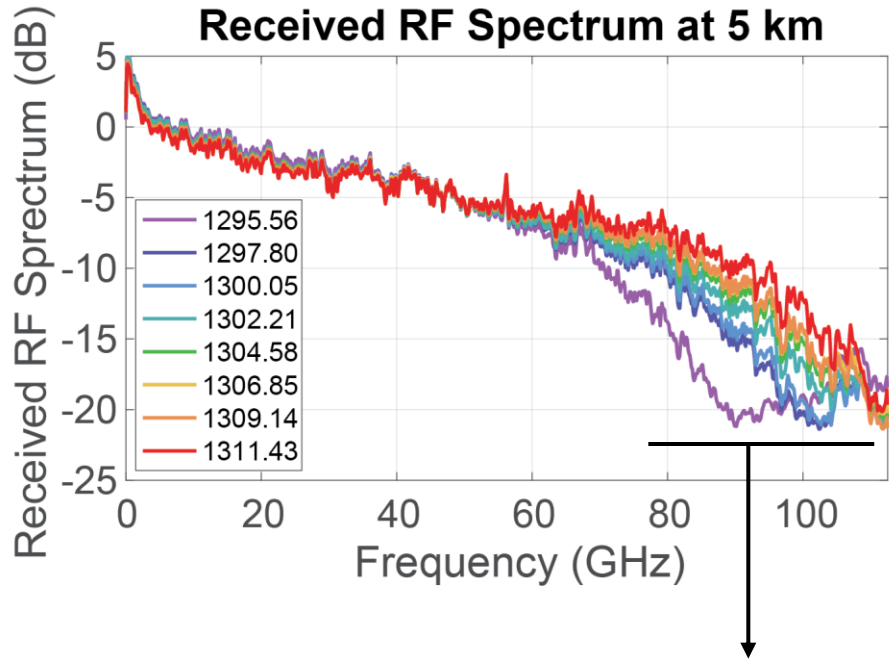

8 x Net 375 Gbps  
Net 3.0 Tbps  
(20% SD-FEC)

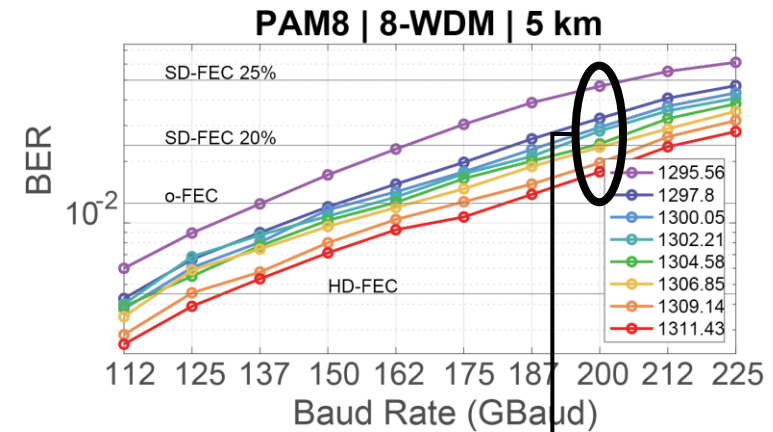

8 x Net 480 Gbps  
Net 3.84 Tbps  
(25% SD-FEC)

Severe CD-induced power fading and dips observed

- Impact edge-most channels performance
- **Cannot achieve Net 3.2 Tbps with PAM4 at 5 km**
  - Need more optimized WDM grids
  - Centered on the zero-dispersion wavelength?

# DR8 Experimental Setup

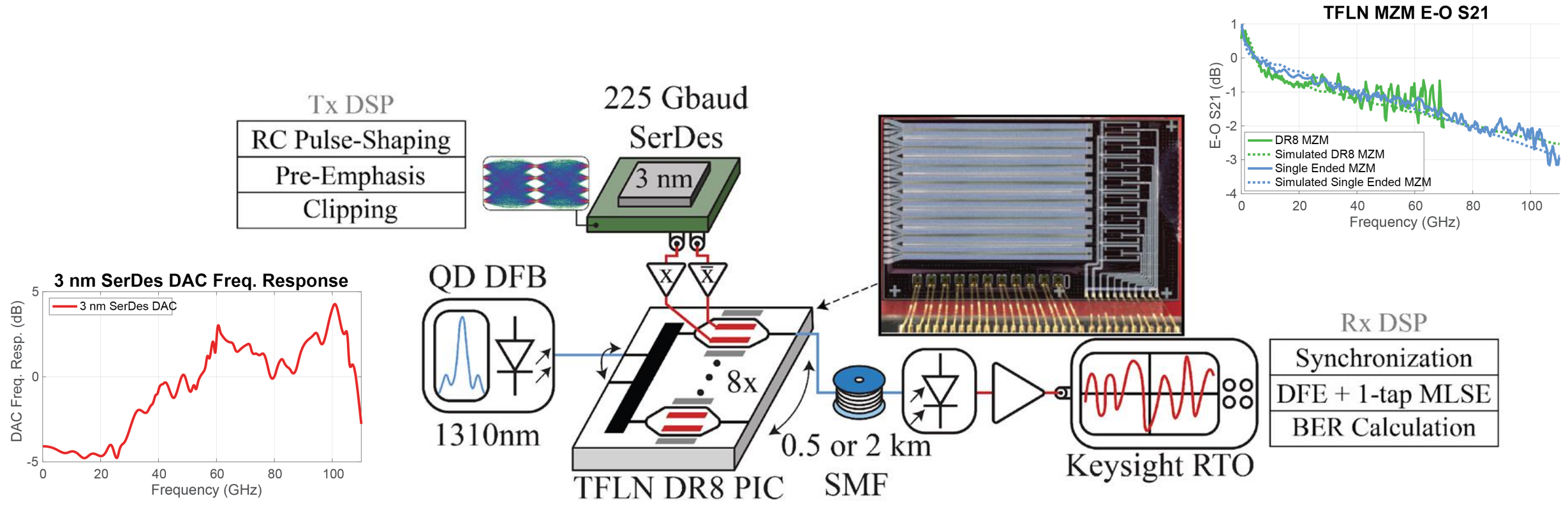

# DR8 TFLN chip Design Challenges

- DR8 requires 8 parallel MZMs
  - TFLN devices typically tend to be longer (~ 10 mm)
    - Makes for large TFLN die
  - How can we make the MZM shorter?
    - i.e., Reduce the  $V_{\pi}L$  ?

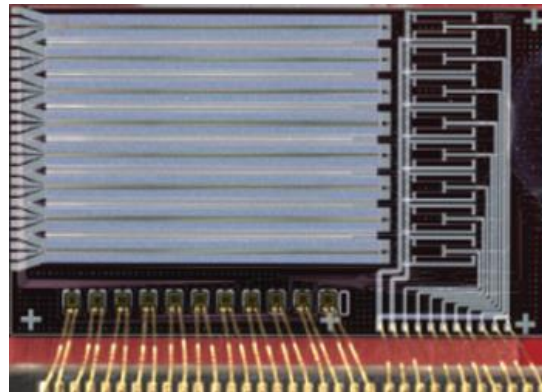

# Optimizing MZM length – Novel approach

- Currently available TFLN products are built on x-cut TFLN
  - $E_{field}$  must align with z-axis of TFLN crystal for highest Pockels coefficient
    - Not compatible with chirp-less differential push-pull designs
    - Electrode cannot be placed on top of the waveguide
      - Much reduced Pockels coefficient
  - Differential push-pull increases field amplitude across waveguide
    - Reduces  $V_{\pi}L$

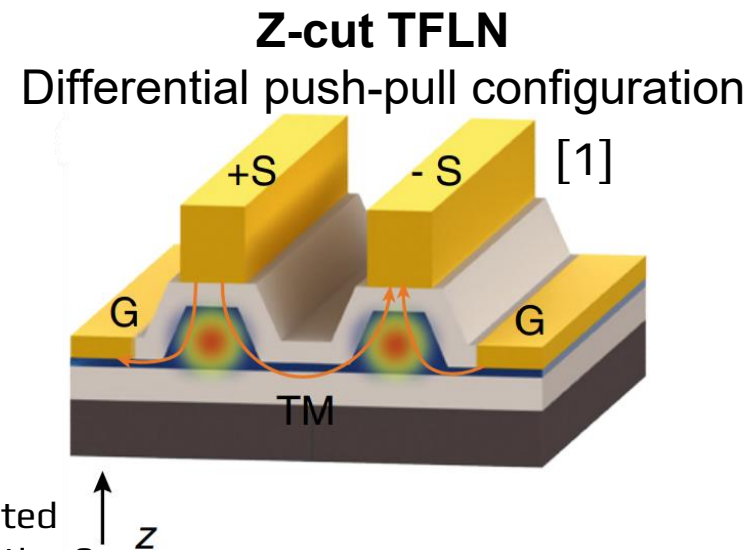
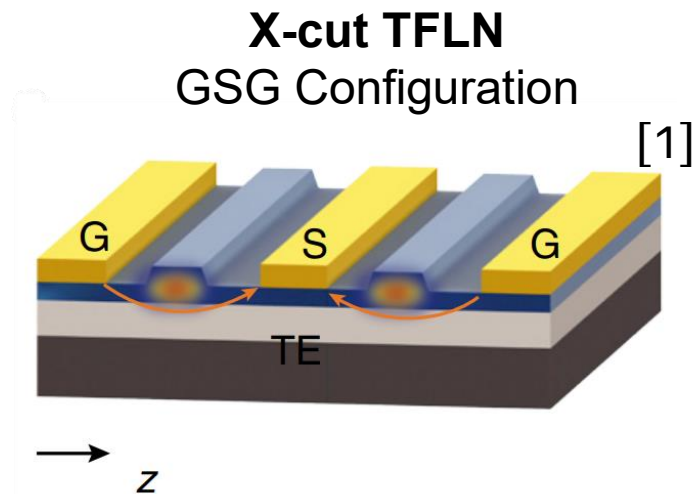

[1] Mian Zhang, Cheng Wang, Prashanta Kharel, Di Zhu, and Marko Lončar, "Integrated lithium niobate electro-optic modulators: when performance meets scalability," Optica 8,

# Optimizing TFLN MZM length – Novel approach

- Semi-differential push-pull design
  - Allows for reduction of  $V_{\pi}L$
  - Introduces a  $\pm 1/3$  chirp factor
    - Causes pulse shortening or broadening in the presence of chromatic dispersion

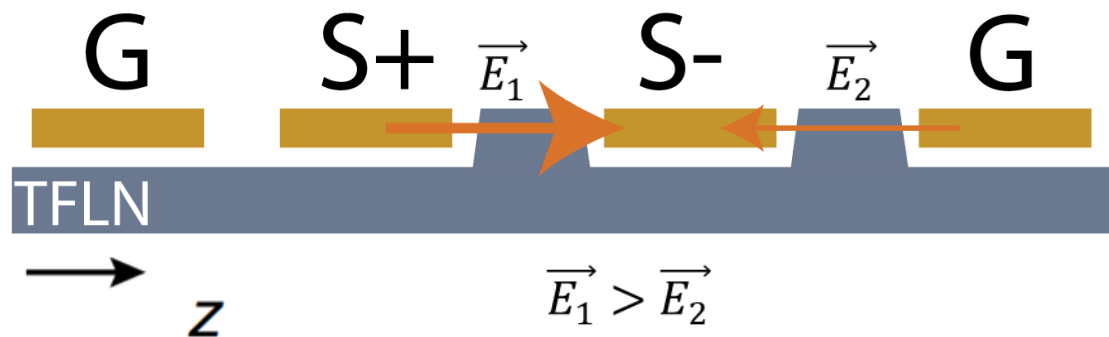

DR8 standard wavelength range

- 1304.5 – 1317.5 nm
- Tightly constrained around SMF28 ZDW
  - Short distance
  - Low CD accumulation

- Design allows for MZM length of 6 mm only with a 4.5 V differential  $V_{\pi}$ 
  - 6-dB bandwidth extrapolated with simulations to  $> 150$  GHz

# PAM4(8) 500m & 2 km - DR8 Results

- Net 3.2 Tbps 225 Gbaud PAM4

- 500 m and 2 km
- HD-FEC

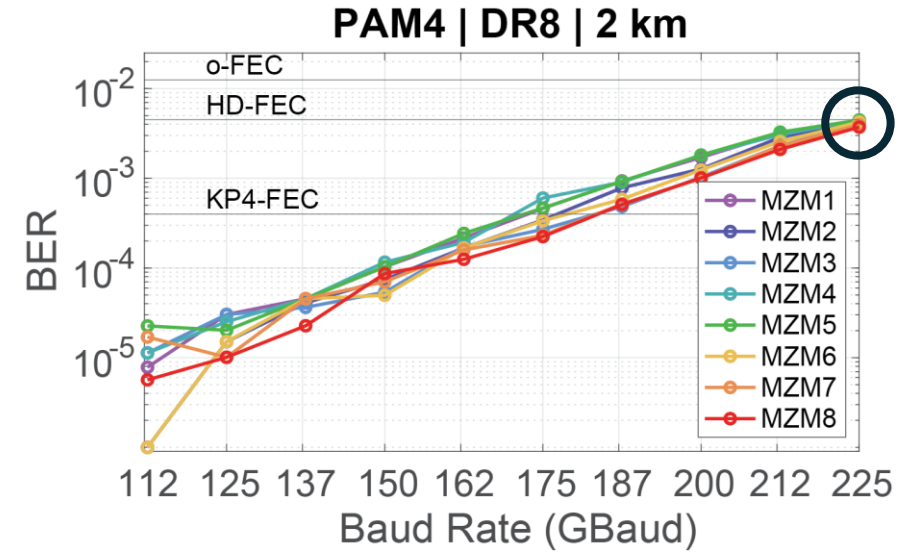
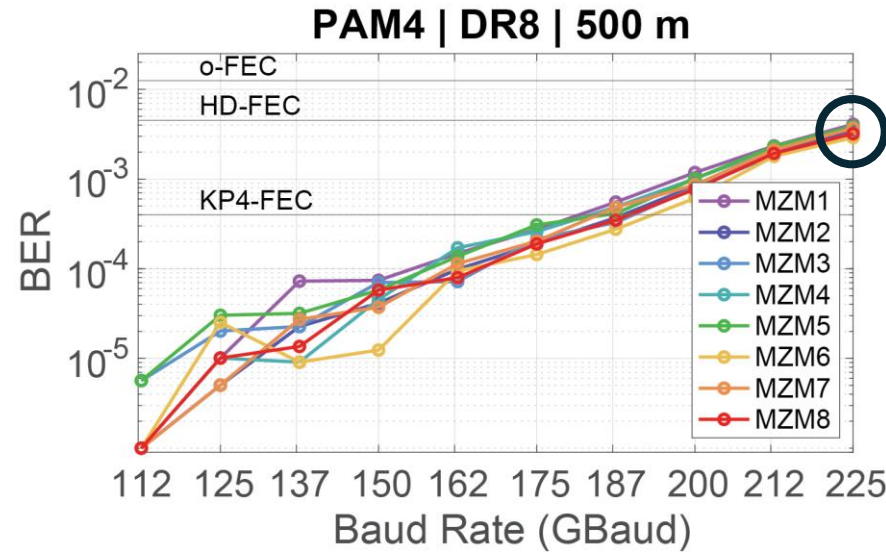

- Net 4.2 Tbps 225 Gbaud PAM8

- 500 m and 2 km
- 25% SD-FEC

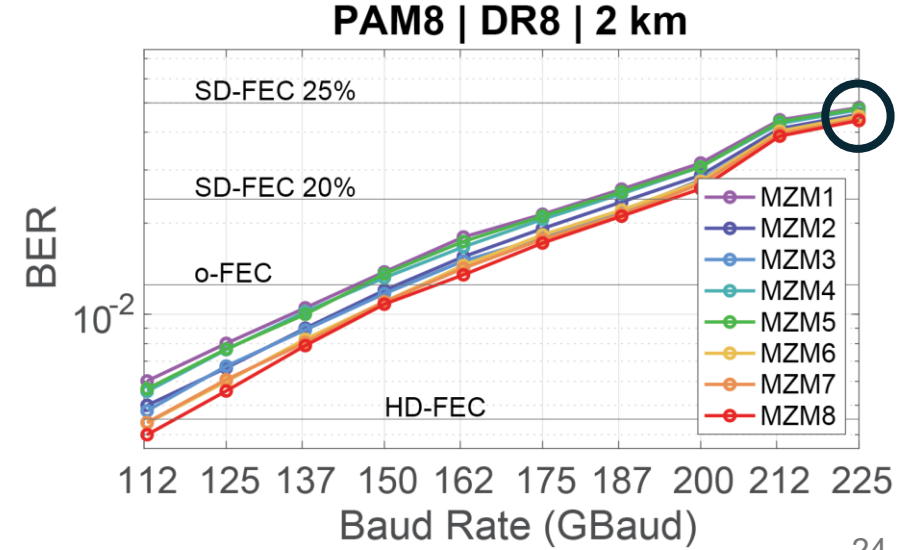
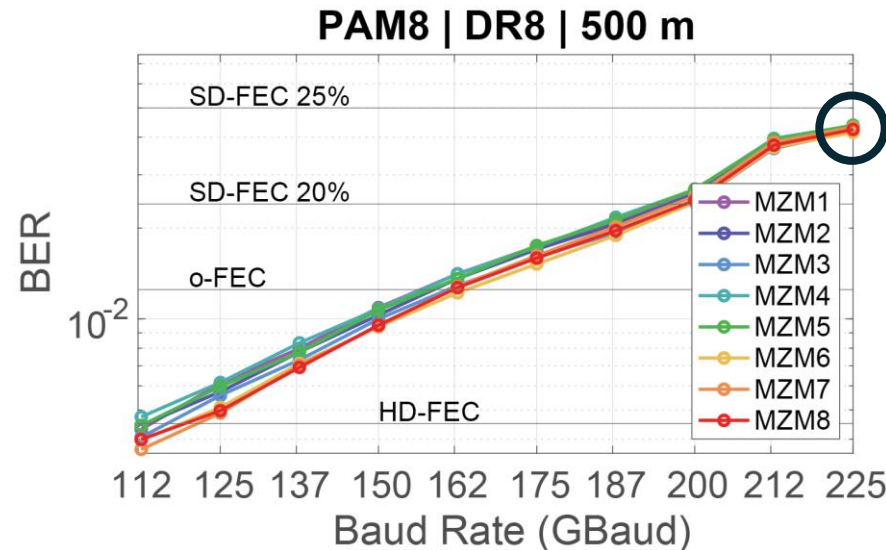

# Uncooled Operation - DR8 Results

- DFB laser operating temperature swept
  - From 30°C to 85°C
- BER remains under HD-FEC
- Carrier wavelength varies:
  - 1308.3 nm to 1315.7 nm
  - Complies with 200 Gbps/lane DR8 Ethernet standard operating wavelength spec.

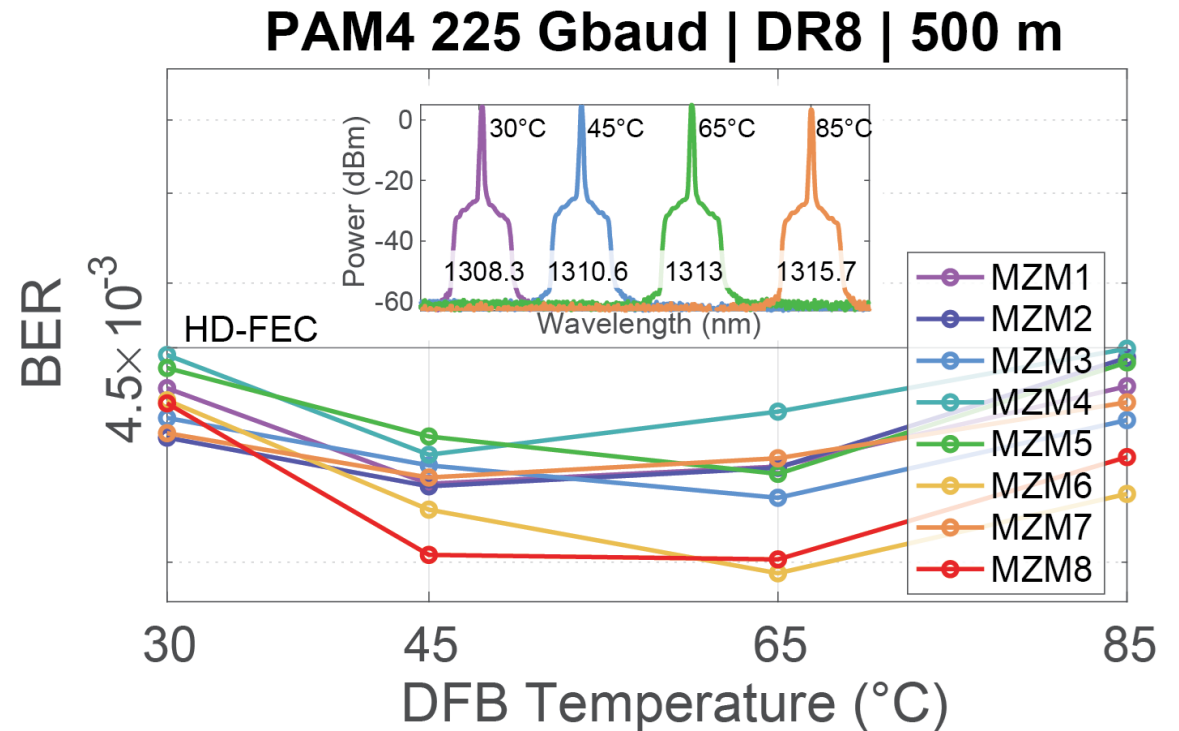

# Conclusion

- We achieved the industry's first 448 Gbps PAM4 back in March 2025
- Receiver equalizer for 448Gbps/lane will need to be more powerful than to account for current BW limitations and noise
- Adding 1-tap MLSE to FFE or DFE provides significant improvements
- Using FR8, DR8 and DR8+, we achieve :
  - 3.2 Tbps (PAM4)
  - 4.2 Tbps (PAM8)

# Driverless 448 Gbps PAM4

- Press-release to come tomorrow
  - McGill, Ciena, HyperLight

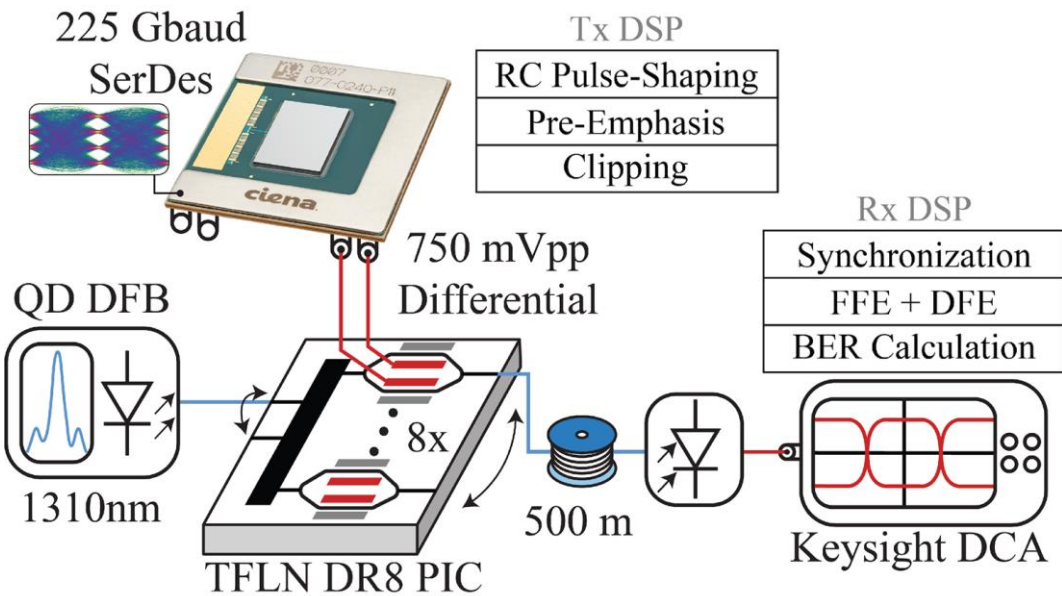

St-Arnault, *et al.*, to be published, 2025.

Driverless PAM-4 | 225 Gbaud

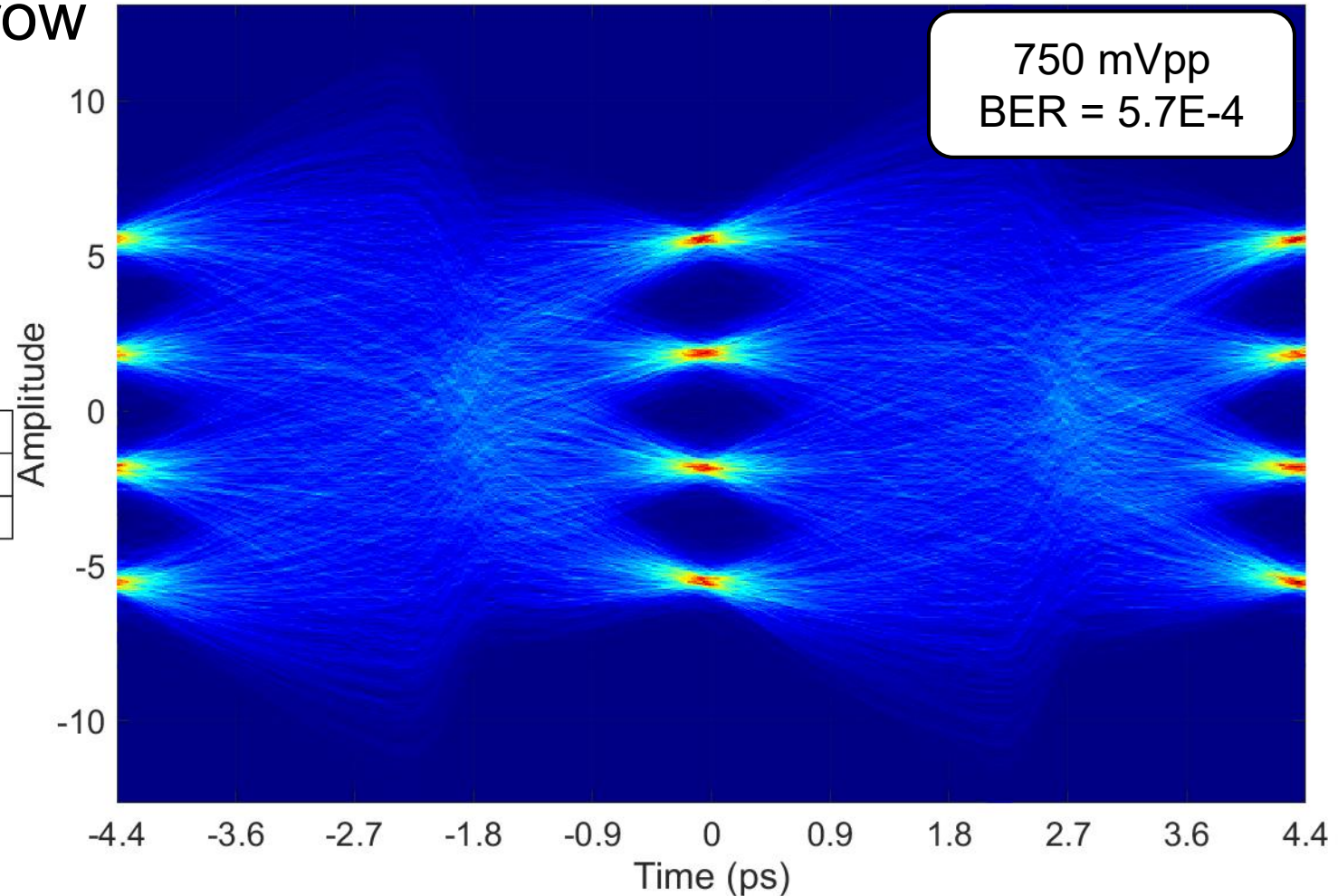

# Faster-than-Nyquist Transmission

- ECOC 2025 | M.02.07.4 Talk
  - Upgraded to invited
  - Monday 2h30 pm

# Faster-than-Nyquist Transmission

- Pushed the Ciena 3nm DAC beyond the sampling rate limit
  - Achieved 320 Gbaud PAM4 – Net 512 Gbps
  - Achieved 252.5 Gbaud PAM8 – Net 606 Gbps

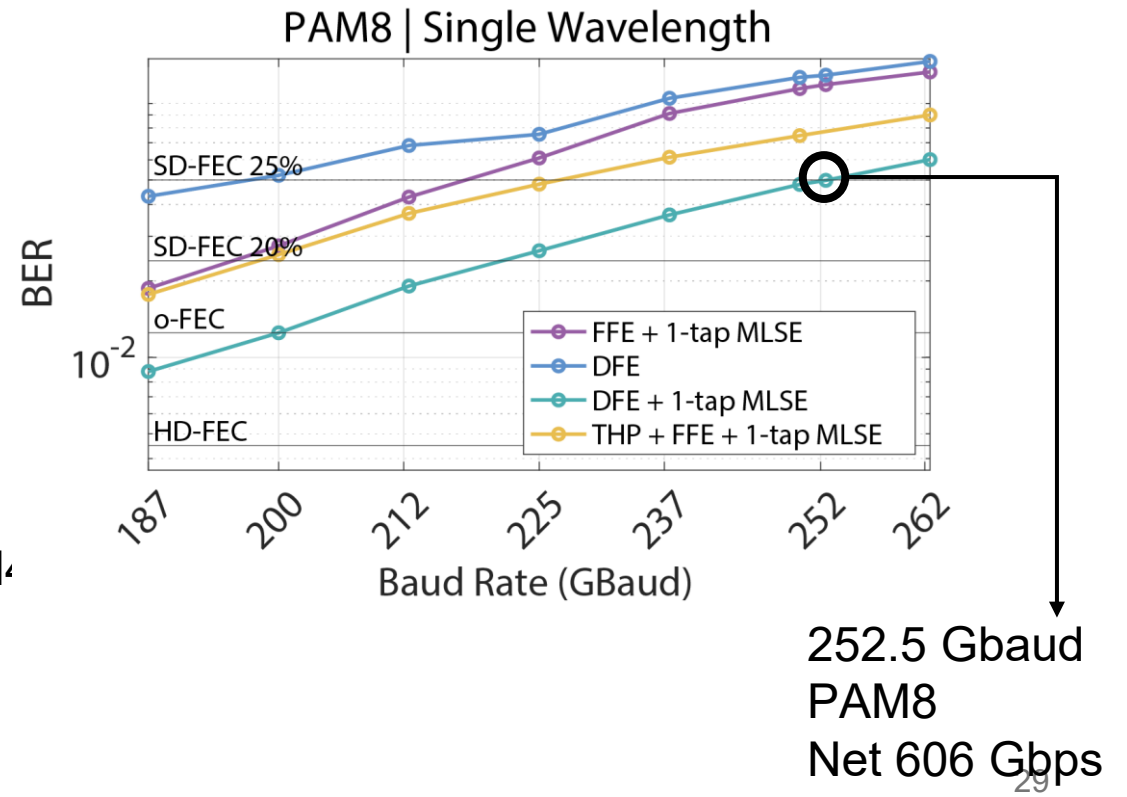
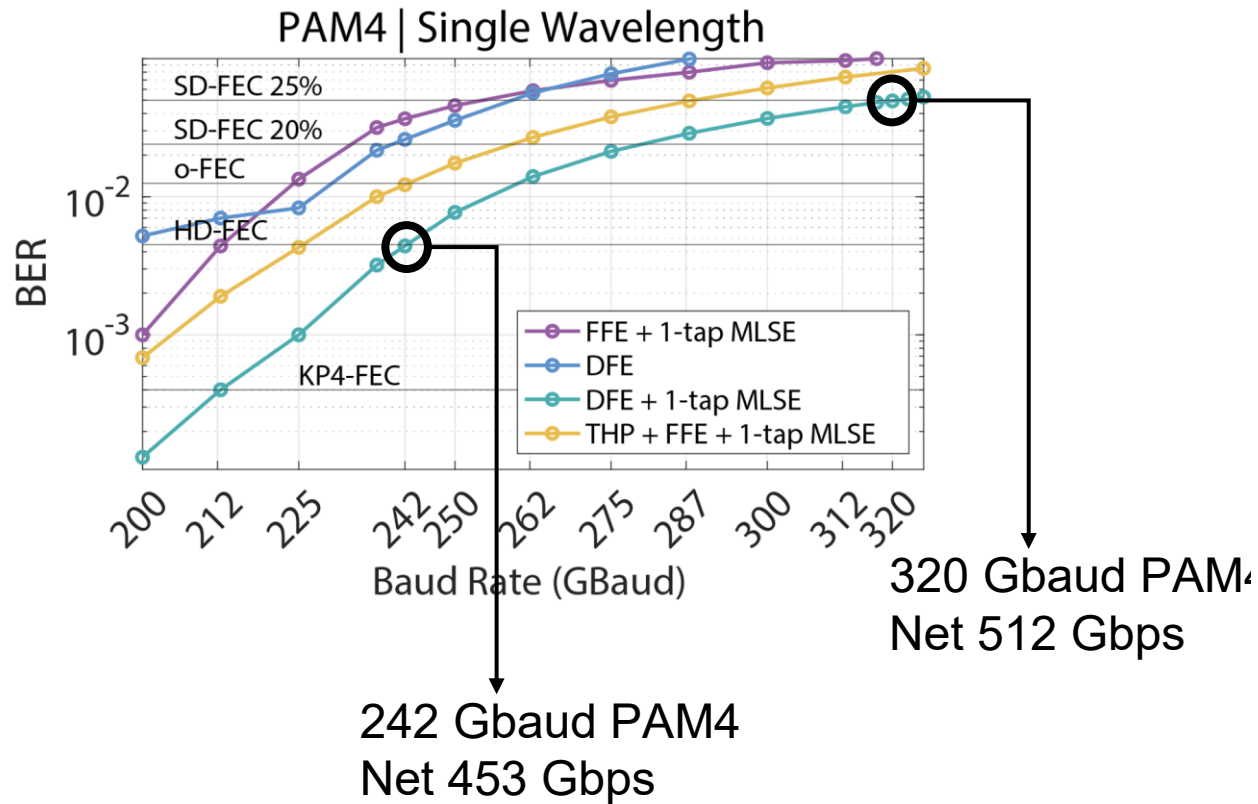

# Special Thanks

- This work was enabled by our collaborators
  - Ciena (Ottawa)
  - HyperLight
  - Keysight

# Questions?