



Long reach, low power fronthaul DWDM:
quasi-coherent technologies

DSP-free Coherent for Fronthaul – why, how, and what?

- **Latency** - We should aim to not increase the latency over that of IMDD transceivers to maintain tight synchronization
- **DWDM reach** – 15 to 20 km reach in the C-band is required even at 50 Gbps line rates
- **Power Consumption & Formfactor** – Maintaining an SFP formfactor dictates less than 3 Watt pr. Module over I-temp. 2-2.5 Watt is preferred

DSP-free Quasi-Coherent Receiver technology has the potential to deliver on all three points

What do we mean by “Quasi-Cohrent”?

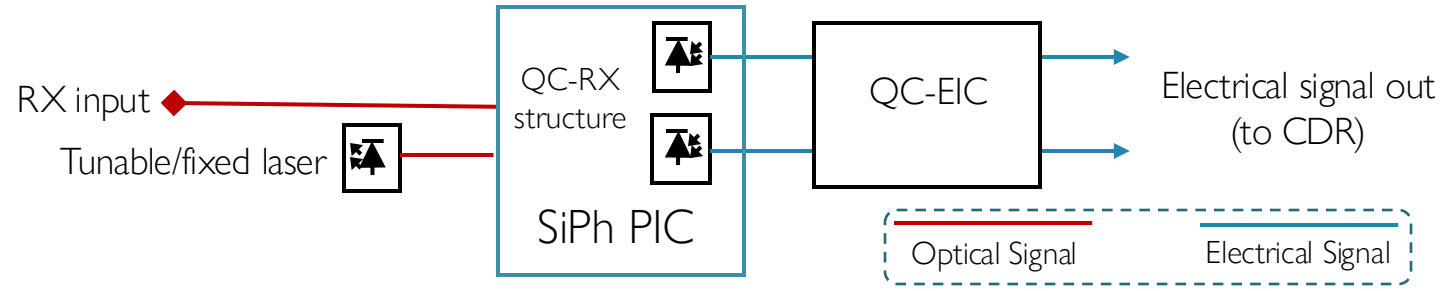

- Beating the incoming signal with an LO laser provides amplification
- Optical heterodyning removes the need for carrier-phase recovery for IM signals (hence quasi 😊)
- Optical heterodyning converts the optical signal to RF while maintaining frequency and phase information – enables simple, latency-free dispersion compensation
- Heterodyning demands higher PD bandwidth, but Silicon Photonics standard PDKs can deliver this today
- Low-cost DFB LO laser adds power consumption, but 1 Watt SFP total power consumption at room temperature is achievable. At 1-temp 2.5 Watts is realistic

Chromatic Dispersion in time domain

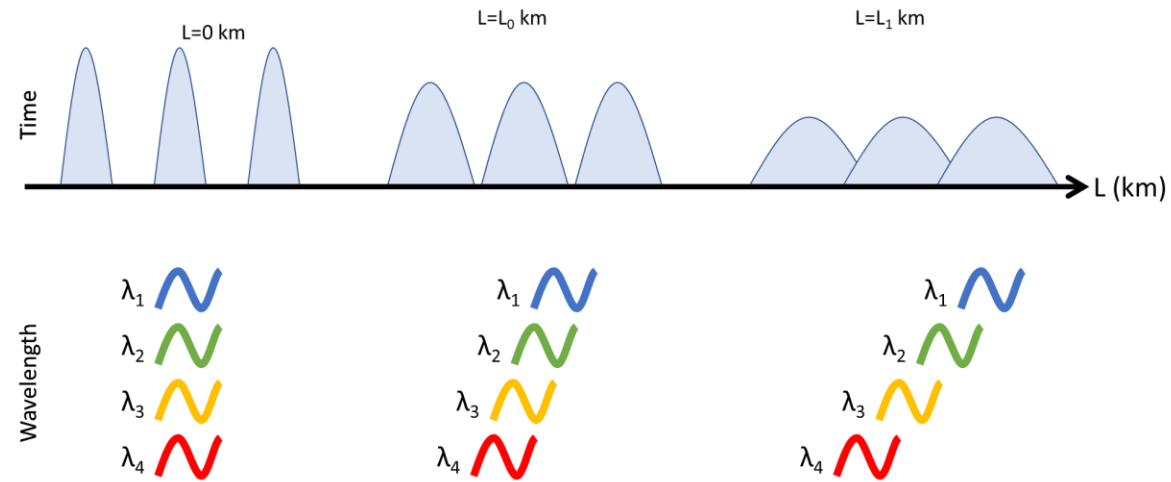

- Frequency dependent group delay causes different spectral components of the signal to travel through the fiber at different speeds, thus leading to pulse broadening and inter-symbol interference (ISI)
- Doubling the symbol rate doubles the spectrum, but in addition halves the allocated time-slot for each symbol, thereby leading to a 4-times reduction in the dispersion tolerance

Chromatic Dispersion in IMDD receivers

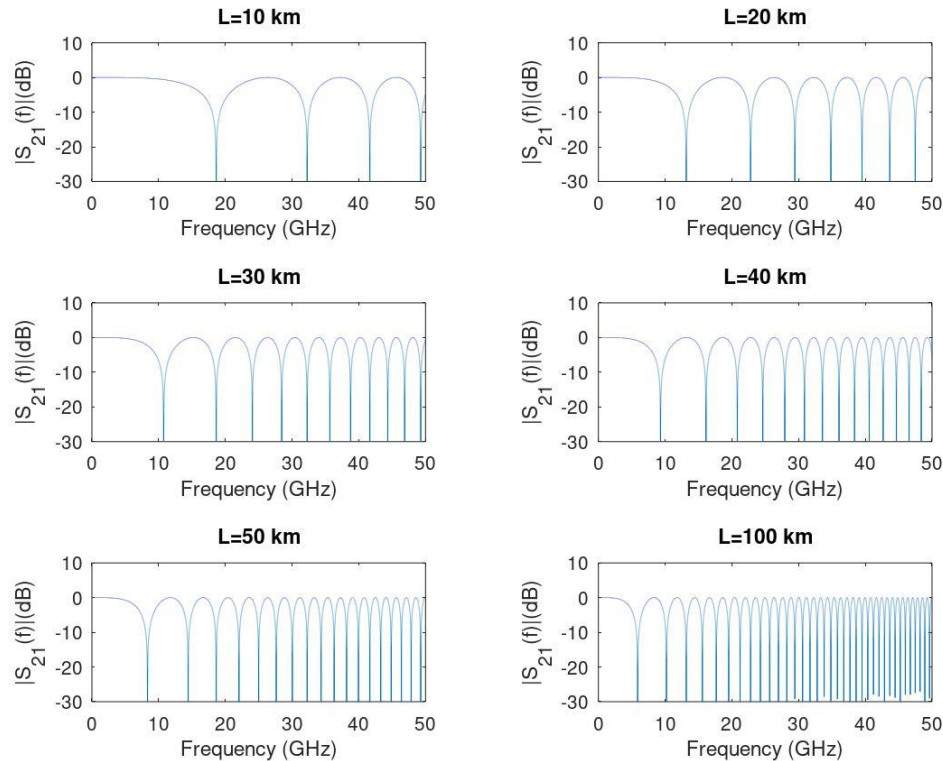
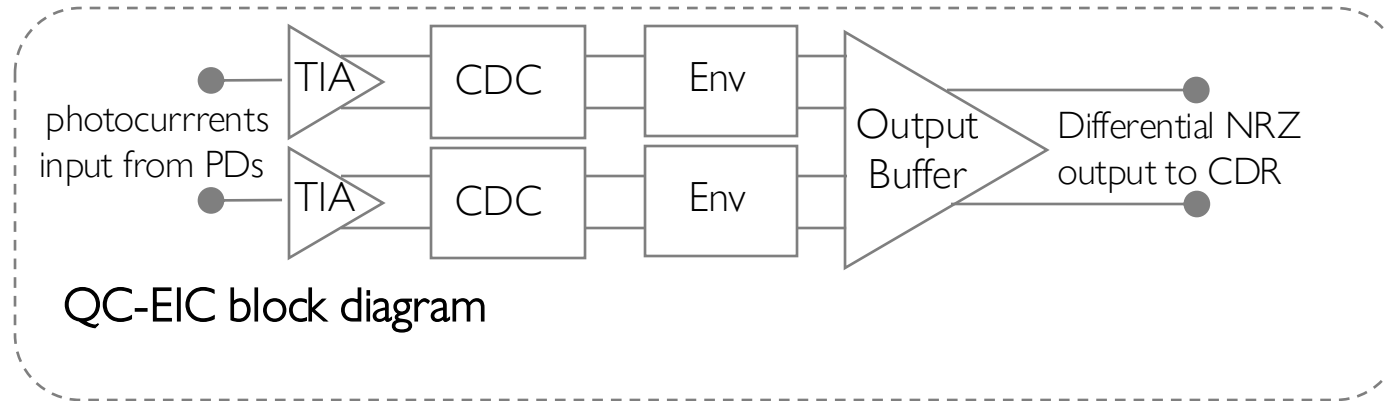

Figure 2. Frequency response for IM/DD link with SSF of 10 km, 20 km, 30 km, 40 km, 50 km and 100 km. Assuming a $D=18$ ps/(nm km) and $\lambda=1550$ nm. [Bifrost patent]

- Notches appear in the detected spectrum due to destructive interference between corresponding frequency components in the upper and lower sidebands
- As chromatic dispersion increases, these notches move closer to DC
- When the notches reach the Nyquist frequency (roughly half the symbol rate, or 12.5 GHz for 25 Gbps NRZ), it is essentially "game over" for IMDD, unless very advanced equalization with more than 3 symbol memory is used
- Quasi-Coherent Receivers can correct this with analog RF signal processing

QC-EIC with dispersion compensation



TIA – Converts photocurrent to voltage and provides gain

CDC – Inverts optical fiber's frequency dependent group delay to compensate chromatic dispersion without adding latency

Env – Envelope detector that converts from RF to baseband without DSP

Output Buffer – Conditions the signal for conventional IMDD clock and data recovery circuits (CDR)

Performance at 25 Gbps

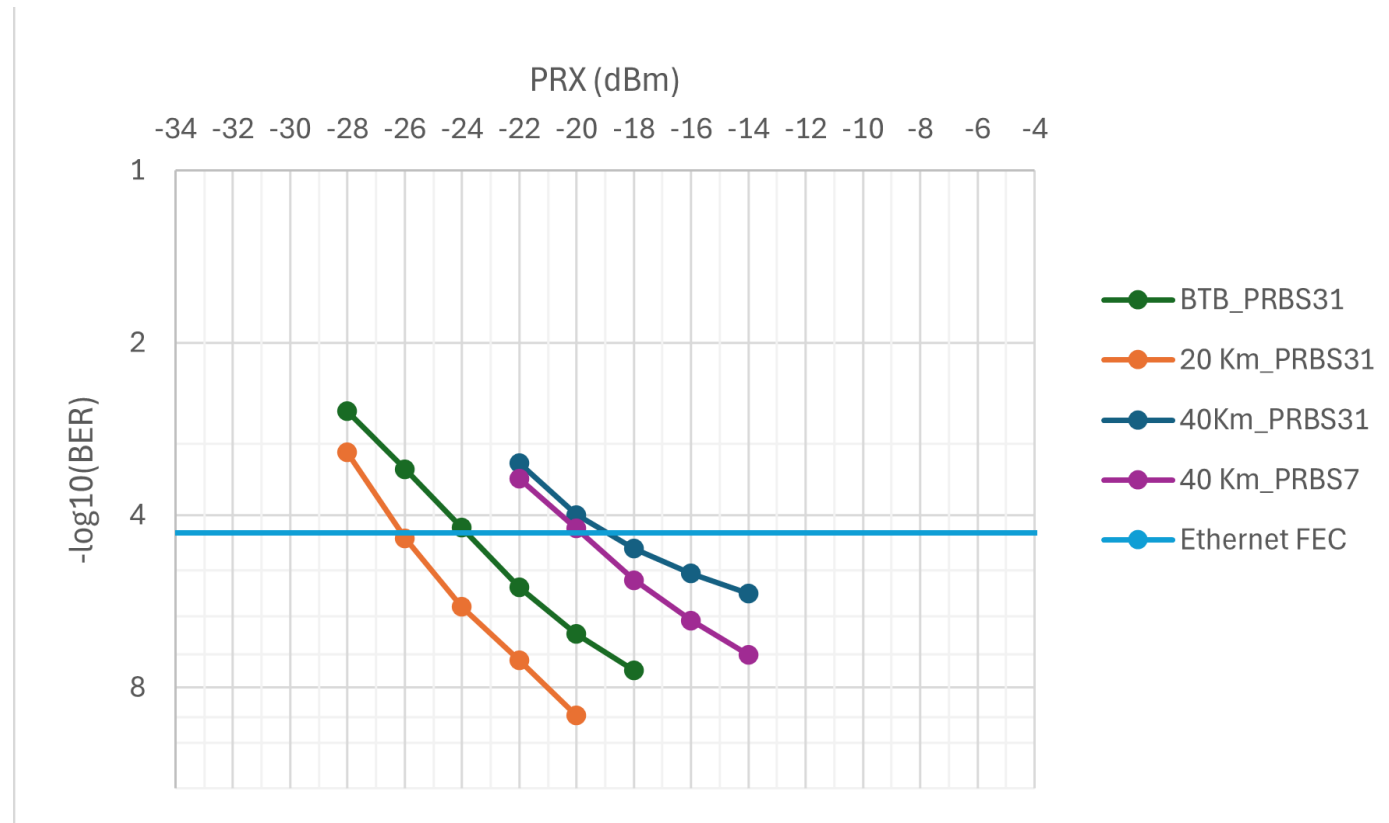

- BER vs received optical power for 25 Gbps QC transceiver for BTB, 20 km and 40 km SSMF transmission.
- Transmitter is a standard EML transmitter
- 50 GBPS PAM4, 20 Km solution under development

Summary and Conclusion

- QC-receiver technology can increase reach and receiver sensitivity over IMDD
- No added latency
- Small increase in power consumption from LO laser
- SFP compatible
- 25 Gbps, 40 km available
- 50 Gbps, 20 km under development



Thank you for your attention
Questions?

Jesper Bevensee Jensen, CTO

✉ jjb@bifrostcommunications.com

☎ +45 2414 4047