



Mobile Optical Pluggables Alliance (MOPA)

Technical paper

Version 3.1

September 22, 2024



Work item drivers (in alphabetical order)

Antonio Tartaglia¹
 Fabio Cavaliere¹
 François Fredricx⁴

Kenneth Jackson³
 Kevin Cheng⁸
 Uwe Schmiade⁴

Stefan Dahlfors¹

Contributors (in alphabetical order)

Alberto Artuso³
 Allard van der Horst⁶
 Andrew Gallant⁶
 Bart Zydel⁸
 David Kuo⁹
 David Sinicrope¹
 Faraz Shouka⁹
 Giacomo Losio²

Giampaolo Bendelli²
 Hock Gin Lim²
 James Kannan³
 Jun Pan⁵
 Justin Abbott²
 Ken Cockerham⁵
 Kumi Omori⁷
 Raza Khan⁶

Ronald Heron⁴
 Ryan Latchman⁸
 Steven Buchinger⁶
 Ulf Parkholm¹
 Tero Kemila⁴
 Zhao Wang⁶

(1) Ericsson, (2) Lumentum, (3) Sumitomo Electric, (4) Nokia, (5) Coherent, (6) Semtech, (7) NEC, (8) MACOM, (9) Point 2 Technologies

Operator Advisory Board (in alphabetical order)

Dirk Breuer¹⁰
 Philippe Chanclou¹ (Chair)
 Henry Cheng⁶
 Edwards James Echeverry Zuleta⁵
 Jun-ichi Kani³
 Francisco Javier Lopez Santolla⁵

Stefan Melin⁴
 Albert Rafel⁹
 Hongseok Shin⁸
 Uladzimir Norka⁴
 Mark T. Watts²

(1) Orange, (2) Verizon, (3) NTT, (4) Telia, (5) Telefonica, (6) T-Mobile, (8) SK Telecom, (9) BT, (10) DT



1. Executive summary

From the International Mobile Telecommunications (IMT) visions for consecutive generations of mobile systems (see the 2020 vision [M2083] for 5G and the 2030 vision [M2160] for 6G) and resulting global and national efforts, the spectrum allocations for mobile systems are growing. This together with innovative and high bandwidth consuming applications drive transport network capacity growth, resulting in an urgent and significant need for high-capacity and cost-effective optical solutions as part of those mobile transport networks.

Consequently, there is a need for a shared and common view of the optical solutions needed for mobile transport [OptConn]. This has several benefits:

- Technological and architectural: fewer and better suited architectures and technologies.
- Cost: operators, system vendors and optical pluggables suppliers can better focus on the most relevant needs.
- Availability: having the right solution commercially available at the right time and at the right cost.

An improved common understanding and focus can be achieved by making mobile optical blueprints resulting in:

- Clear optical pluggable needs for operators, systems vendors and optical pluggable suppliers.
- An eco-system ensuring timely, cost-efficient, and optimized architectures.

By mobile optical blueprint we mean a network solution description documenting a use case with the optical pluggables and passive optical components (wavelength division multiplexing (WDM) mux, splitter, etc.) implementing that use case, with high-level optical and pluggables requirements. The Blueprints in this paper—nineteen in total—cover all globally relevant deployment variants for distributed radio access networks (DRAN), centralized RAN (CRAN) and virtualized RAN (VRAN) for the links connecting the radio units (RUs) with distributed units (DUs), DUs with centralized units (CUs), and CUs with the mobile core.

In light of new needs for mobile optical networks, this 3.1 technical paper makes updates and additions to several areas:

- A new Chapter 10 has been added introducing Cloud RAN optics with a high-level description and summarized responses from a MOPA Operator Advisory Board questionnaire.
- A new section 13.9 has been added related to retimed and linear optics for 100 Gbps SFP112. This section makes a high-level overview of retimed and linear implementations and summarizes responses from the MOPA members on SFP112 implementations.
- Outside this paper, a new stand-alone paper related to tight sync implementations for coherent and other modules is part of this release.

It should be mentioned that much of the content generated by the MOPA group is made as contributions to standardization bodies such as ITU-T, SNIA/SFF, OIF and IEEE.



Contents

1. Executive summary	2
2. Introduction, purpose and scope	6
3. Acronyms	7
4. Legend and nomenclature	9
5. Background: 5G, 6G evolution and optical impact	12
6. Generic optical solutions requirements in mobile transport networks	17
6.1. Operating temperature and power consumption classes.....	17
6.2. Power saving mechanisms.....	18
6.3. EMI and EMC	18
6.4. Latency.....	18
6.5. Synchronization.....	18
6.5.1. Impact of optical pluggables on synchronization.....	18
6.6. Support of multiple bit rates	19
6.7. Form factor standards	19
6.8. Connectors: UPC, APC.....	20
6.9. Tunable and automatic self-tunable DWDM pluggables	20
6.10. Loss budget (channel insertion loss) and chromatic dispersion.....	21
6.11. Lifespan of optical pluggables.....	23
6.12. Remote optical module management.....	23
6.13. Firmware update of optical pluggables.....	23
6.14. Optical module system vendor qualification, interoperability and the role of MOPA	24
7. Mobile Optical Solution Blueprints for LLS in Distributed RAN (DRAN)	26
7.1. Overview.....	26
7.2. DRAN Optical Blueprints.....	29
7.2.1. 2 km RU-DU direct parallel fibers, dual fiber Blueprint	29
7.2.2. 10 km RU-DU direct parallel fibers, dual and BiDi fiber Blueprint	30
8. Mobile Optical Solution Blueprints for LLS in Centralized RAN (CRAN)	31
8.1. Overview.....	31
8.2. Evolution of WDM systems over different bands	33
8.3. CRAN Optical Blueprints.....	33



8.3.1.	15 km RU – DU direct parallel fibers, dual and BiDi fiber Blueprint.....	34
8.3.2.	10 km RU – DU, passive CWDM over a single fiber Blueprint.....	35
8.3.3.	15 km RU – DU, passive LWDM over a single fiber Blueprint	36
8.3.4.	15 km RU-DU, passive DWDM over a single fiber Blueprint	37
8.3.5.	15 km RU-DU, passive DWDM bus over a single fiber Blueprint	38
8.3.6.	15 km RU-DU, semi-active DWDM over a single fiber Blueprint.....	39
8.3.7.	2 km RU-DU packet multiplexing, dual fiber Blueprint	40
8.3.8.	15 km RU-DU packet multiplexing, dual or BiDi fiber Blueprint	41
9.	Mobile Optical Solution Blueprints for Backhaul and HLS	42
9.1.	Overview.....	42
9.2.	Backhaul and HLS Optical Blueprints	44
9.2.1.	2 km DRAN intraoffice backhaul, direct parallel fibers, dual fiber Blueprint	44
9.2.2.	10 km DRAN backhaul, direct parallel fibers, dual and BiDi fiber Blueprint	45
9.2.3.	40 km DRAN backhaul, direct parallel fibers, dual and BiDi fiber Blueprint	46
9.2.4.	15 km DRAN backhaul, passive DWDM bus over a single fiber Blueprint.....	47
9.2.5.	2 km intraoffice CRAN hub site intraoffice backhaul Blueprint.....	48
9.2.6.	10 km CRAN backhaul, direct parallel fibers, dual and BiDi fiber Blueprint.....	49
9.2.7.	40 km CRAN backhaul, direct parallel fibers, dual and BiDi fiber Blueprint.....	50
9.2.8.	15 km CRAN backhaul, passive DWDM over a single trunk fiber Blueprint	51
9.2.9.	20 km DRAN Backhaul and HLS with TDM-PON, Separate ONU box Blueprint ..	52
9.2.10.	20 km DRAN Backhaul and HLS with TDM-PON, Pluggable ONU.....	53
10.	Cloud RAN optical solutions	54
11.	Summary of Optical Pluggables vs. Blueprint	56
12.	Summary of important technologies, capabilities, and components not yet available	59
12.1.	Optical transceivers operating at high temperature.....	59
12.2.	Cost effective high-capacity transceivers.....	59
12.3.	Pluggable optical amplifiers and dispersion compensators	60
12.4.	Cost-effective tunable filters and wavelength switches	60
13.	Solutions under evaluation and future work.....	61
13.1.	LLS using TDM-PON with separate ONU box	61



13.2.	LLS using TDM-PON with pluggable ONU.....	61
13.3.	Higher speed TDM-PON technologies.....	62
13.4.	LLS using semi-active DWDM wavelength multiplexed links over a power splitter ODN (WS-WDM-PON).....	62
13.5.	50 Gb/s xWDM 15 km LLS blueprint	63
13.6.	LLS data rate auto-negotiations.....	63
13.7.	30-40 km LLS WDM solutions	64
13.8.	100 Gb/s IM/DD LLS WDM solutions.....	65
13.9.	100G retimed and linear technology outlook.....	66
14.	Conclusion	68
15.	References	69
Appendix A: Referenced Physical Layer Standards Exceptions for MOPA Blueprints ..		71
Annex A: 50 Gb/s xWDM 15 km LLS blueprint.....		79
1.	Implementations under study.....	80
2.	Candidate O-band wavelength grid vs Four-wave mixing penalties	81
3.	Preliminary Blueprint	85
4.	References	86
Annex B: Remote optical module management.....		88
1.	Description of the application	89
2.	Message channel characteristics.....	90
3.	Frame structure and message types	91
4.	SFP memory pages and registers	92
5.	Operations enabled by the message channel	93
5.1	The value and standardization of remote monitoring and management of optical modules	93
5.2	Proposed Remote-Performance Monitoring (RPM) method	93
5.3	Autonomous module tuning	94
5.4	Proposed remote tuning method	94
6.	References	94



2. Introduction, purpose and scope

From the International Mobile Telecommunications (IMT) visions for consecutive generations of mobile systems (see the 2020 vision [M2083] for 5G and the 2030 vision [M2160] for 6G) and resulting global and national efforts, the spectrum allocations for mobile systems are growing. This together with innovative and high bandwidth consuming applications drives transport network capacity growth, resulting in an urgent and significant need for high-capacity and cost-effective optical solutions as part of those mobile 5G transport networks.

To better support the industry to optimize efficiency and time plans, this technical paper aims to describe uses of optical technologies and solutions across mobile transport in a clear way, as elaborated below.

This document describes and clarifies what the authors think is needed for the mobile RAN equipment for optical pluggables. This description makes it clear what function is needed and lowers the barrier to entry by making it clear what to develop for the RAN equipment environment without wasting time and investment on unnecessary solutions for which there is no demand. Ideally this would result in robust, competitive offerings of optical components and solutions for the mobile environment to the ultimate benefit of consumers.

By mobile transport we mean networks to connect RAN equipment such as RUs, DUs and CUs, including eNodeB and gNodeB, and also transport equipment such as cell site gateways and active WDM equipment dedicated to mobile traffic¹.

This paper outlines important RAN deployment cases (see e.g. [G8300]) and the optical solutions best suited to these cases. The solutions in this paper are called mobile optical solution blueprints, or just Blueprints, encompassing the optical technologies—mainly optical pluggable modules but also accompanying components such as WDM filters—best suited to satisfy deployment needs. Optical pluggables are defined as front-panel pluggable optical transceivers in popular form factors like SFPxy, QSFPxy, etc. and the Blueprints are intended as global solutions, i.e., as generic as possible to cover a wide range of network scenarios.

This paper organizes and integrates existing standards and implementation agreements produced by Standards Development Organizations (SDO), Industry Fora and multi-source agreements (MSAs), where the Blueprints cover the different technical aspects, forming a broad description of optical solutions useful and important for mobile transport networks.

This paper will look at the mid-term future identifying new Blueprints and possible new standardization activities considered of strategic interest for mobile transport networks.

Another way to clarify the important optical solutions for mobile transport is to classify them according to

1. Important solutions with wide consensus in the mobile transport industry.
2. Solutions in discussion where the importance is not yet concluded/agreed.
3. Solutions with a wide consensus seen as not important in the mobile transport industry.

The paper mainly deals with the first category, with some examples of the second outlined in Section 12.

¹ In this document, RAN node terminology is reused from [TS38306], [TS38470] and [GSTR-TN5G].



3. Acronyms

5G	5th Generation mobile networks, generic term for 5G system (or just the RAN part)
5GC	5G core, packet core part of 5G system
6G	6th Generation mobile networks
AI	Artificial Intelligence
AAV	Alternative Access Vendor
APC	Angled Polished Connector
AWG	Arrayed Waveguide Grating (optical DWDM multiplexer)
BiDi	BiDirectional (using a single fiber strand for both transmission directions from an optical pluggable pair, where the two directions use different wavelengths)
BER	Bit Error Rate
C-band	The conventional fiber transmission band, around 1550 nm (aka "3rd window")
CapEx	Capital expenditure
CD	Chromatic Dispersion
CO	Central Office
CRAN	Centralized RAN
CPRI	Common Public Radio Interface
CU	Central Unit
CWDM	Coarse WDM (20 nm wavelength spacing)
DAC	Direct Attach Copper (cable)
DCO	Digital Coherent Optics
DDM	Digital Diagnostics Monitoring
DFB	Distributed Feedback (laser)
DRAN	Distributed RAN
DWDM	Dense WDM (≤ 0.8 nm wavelength spacing in C-band)
DU	Distributed Unit
eCPRI	Ethernet-based CPRI
FP	Fabry-Pérot (laser)
FWM	Four-Wave Mixing
HLS	High-Layer Split
HTMC	Head-to-Tail Message Channel
IL	Insertion Loss
IM-DD	Intensity Modulated – Direct Detection
LC	Optical Connector
LLS	Low-Layer Split
LO	Local Oscillator
LWDM	Local Area Network (LAN) WDM
MPI	Multi-Path Interference
MSA	Multi-Source Agreement
NR	New Radio, RAN part of 5G system
NRZ	Non-Return to Zero modulation
O-band	The original fiber transmission band, around 1310 nm (aka "2nd window")



ODN	Optical Distribution Network
ONU	Optical Network Unit (for TDM-PON)
OLT	Optical Line terminal (for TDM-PON)
OpEx	Operational expenditure
OPP	Optical Path Penalty
P2MP	Point-to-multipoint
P2P	Point-to-point
PAM4	Pulse Amplitude Modulation, 4 levels
Phy	Physical layer (optical)
Pkt	Indicates a node for packet switching and aggregation. May include mapping CPRI to packet, TDM to packet, etc.
PTP	Precision Time Protocol
QSFP	Quadruple-density Small Form factor Pluggable
RAN	Radio Access Network
R-DDMI	Remote – Digital Diagnostics Monitoring Interface
ROSA	Receive Optical Sub-Assembly
RPM	Remote Performance Monitoring
RU	Radio Unit
SDO	Standards Development Organization
SNR	Signal to Noise Ratio
SFP	Small Form factor Pluggable
STO	Self-Tuning Optic
TDP	Transmitter Dispersion Penalty
TDECQ	Transmitter Dispersion Eye Closure Quaternary
TOSA	Transmit Optical Sub-Assembly
UC	Use Case
VHT	Very High Temperature (range)
VRAN	Virtual RAN
WDM	Wavelength Division Multiplexing. In a node, WDM indicates an active WDM equipment, also known as a WDM transponder
WL	WaveLength
WR	Wavelength Routed
WS	Wavelength Selected

4. Legend and nomenclature

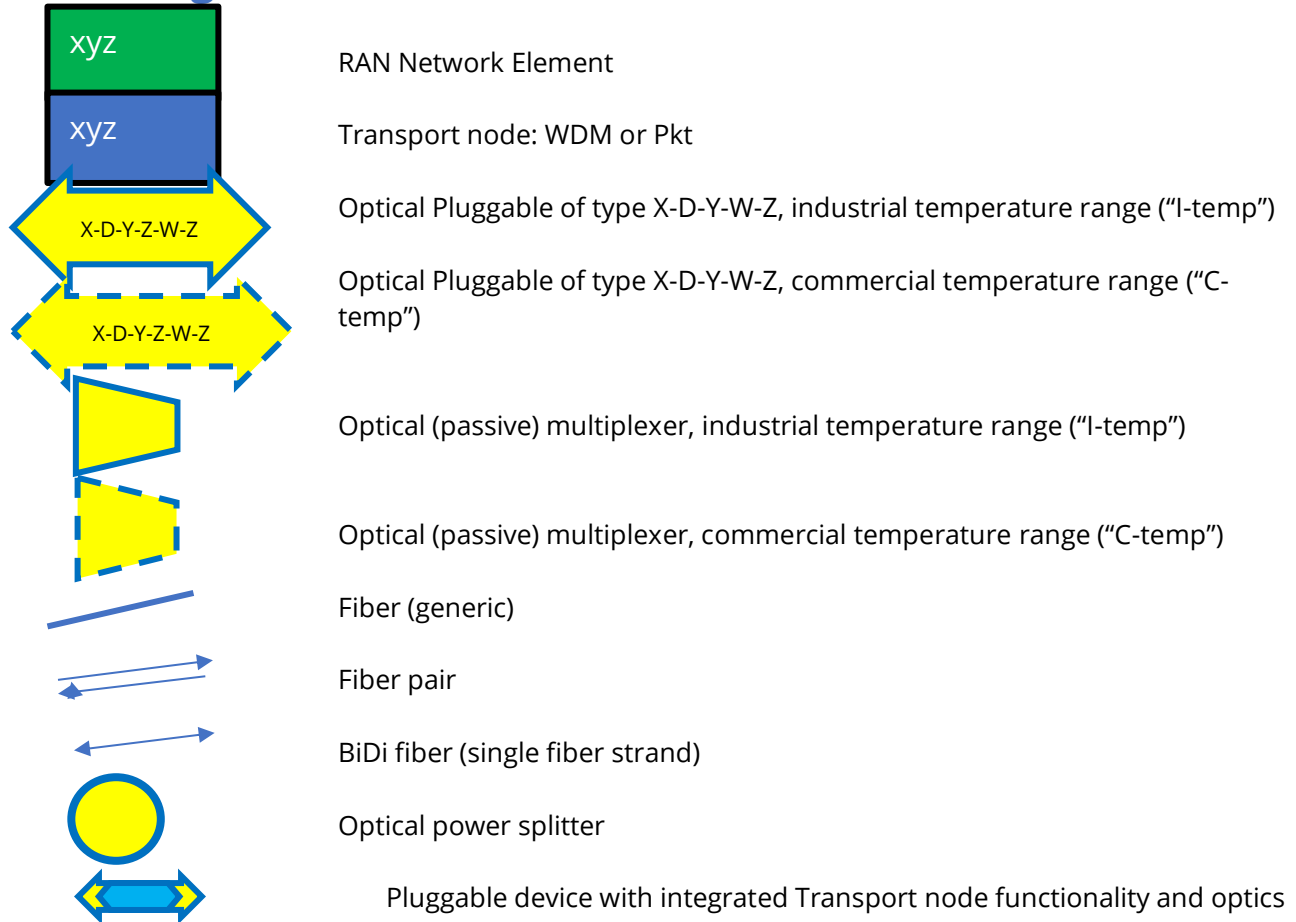

The optical pluggable type in the icons above is meant to provide an indication at a glance of the category to which the transceiver belongs. It is intended to be a compact and not all-encompassing description: detailed characteristics are provided in the optical Blueprints description in sections 7-9, with further details in *Appendix A: Referenced Physical layer Standards Exceptions for MOPA Blueprints*. The different type fields is defined in Table 1.



X Bit rate	D Distance	Y1 Wavelength region(s)	Y2 WDM grid	Y3 Number of wavelengths / fiber strand	W Fiber mode 1=BiDi 2=dual	Z Form factor
10G	2 km	O (1260-1360 nm)	G – gray	1	1	SFP+
25G	5 km	E (1360-1460 nm)	(wavelength generic)	2	2	SFP28
50G	10 km	S (1460-1530nm)	B1 – BiDi 1270nm/1310nm	4		SFP56
100G	15 km	C (1530-1565nm)	B2 – BiDi 1270nm/1330nm	6		SFP112
200G	20 km	L (1565-1625nm)	B3 – BiDi xxxx / yyyy nm	8		QSFP+
400G	40 km	** (all bands, only for CWDM)	L – LAN-WDM (4.5nm)	12		QSFP28
GPON	80 km		D – DWDM (100 GHz, 0.8nm)	16		QSFP56
XGSPON			DL – DWDM with wavelocker (50 GHz, 0.4nm)	48		QSFP-DD
25GSPON			C – CWDM (20nm)	96		QSFP-DD56
						SFP-DD
						SFP-DD56
						DSFP
						DSFP56
						(prefix T is used for tunable)

Table 1: Optical pluggables codes nomenclature².

Some examples of using this nomenclature are illustrated below:

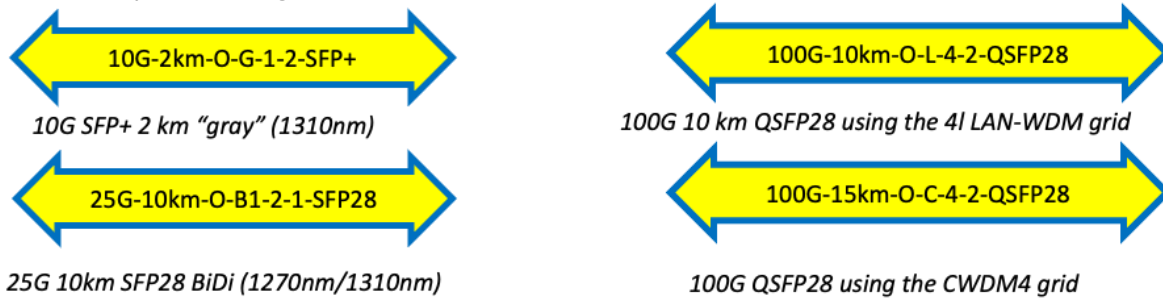

Figure 1: Example of icons and codes for "client" pluggables.

² It should be noted that some values and variants are not yet used for the Blueprints in this paper, e.g. the distances 5, 20 and 80 km.

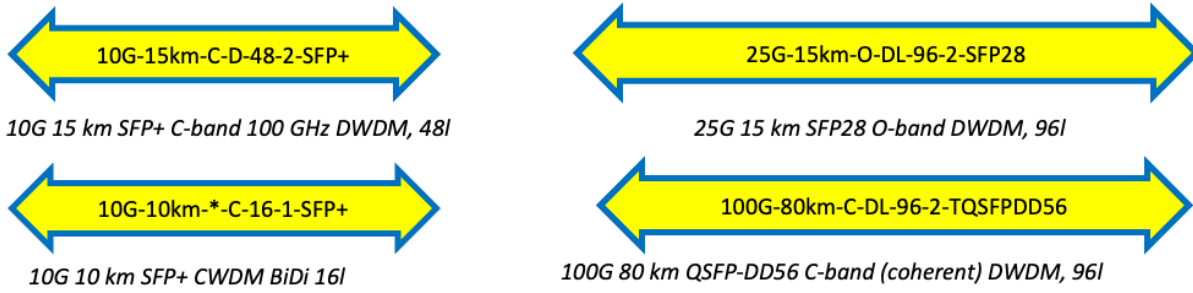
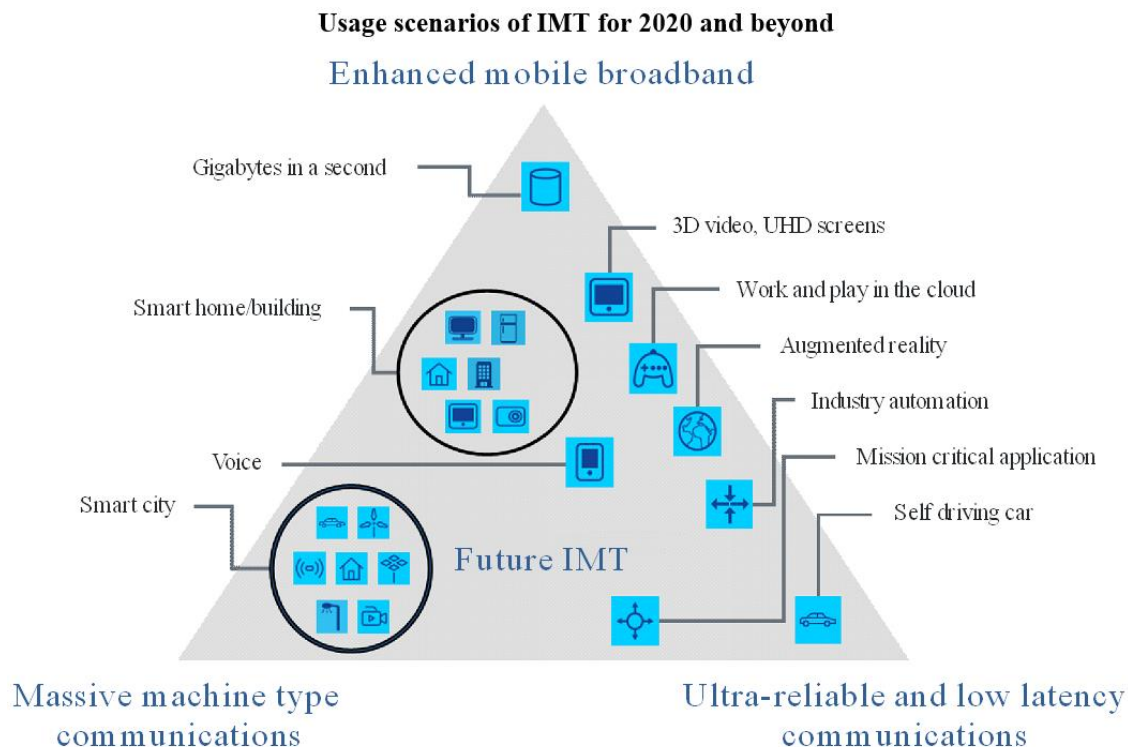

Figure 2: Example of icons and codes for "line" pluggables.

5. Background: 5G, 6G evolution and optical impact

With 5G research starting in the early 2010s [Wiki5G], and standardization efforts in 3GPP and ITU starting a few years later, the goals were to provide an enhanced mobile broadband experience as well as add capabilities for very scalable cellular networks for massive machine type communications (MMTC), and ultra-reliable and low-latency communications (URLLC). This is described in ITU-R M.2083 [M2083] and illustrated in Figure 3.



M.2083-02

Figure 3: IMT 2020 vision from ITU-R M.2083.

For the first goal, much larger pieces of spectrum are planned for 5G compared to LTE (see [LTEbands], [NRbands]) and bands can be combined for even more spectrum. With such a wide spectrum, the peak data rates for a radio unit can reach well beyond 10 Gb/s (see Section 4.1.2 in [TS38306]). Thus, the physical line rates for the optical pluggables used in radio units must be at least 10 Gb/s, often 25 Gb/s with 50 Gb/s and 100 Gb/s as next steps. Another driving factor is the consolidation of RAN baseband processing, performed by distributed units (DUs), to fewer locations: DUs are moved from the cell sites to central locations. Centralized RAN (CRAN) deployments started even before 5G and are steadily continuing also with the addition of small cells. Having said that, DRAN is today the dominant deployment variant. In CRAN, due to the longer distance between RUs and DUs, the interconnect is no longer simply cabling

at the mobile site but becomes a transport network, making it more challenging to meet stringent latency requirements between RU and DU and growing in complexity and cost. A generic name for the interface between RU and DU is Low-Layer Split (LLS, [TS38801]), where CPRI and eCPRI are common connectivity protocols, encapsulated in IP and Ethernet. High-Layer Splits (HLS) and the 3GPP F1 transport interface [TS38470] allow the partitioning into DU and CU, resulting in an architecture commonly referred to as virtual RAN³. Requirements for F1 transport are similar to the interfaces between RAN and the mobile core, i.e. S1 and N3 (for EPC and 5GC, respectively), commonly called backhaul [GSTR-TN5G].

While commercial 5G networks are being deployed worldwide and the technology and capabilities are continuously evolving, the research and development of the 6th generation mobile networks is gaining momentum and the ITM-2030 vision was recently published [M2160]. Figure 4 below shows a proposed timeline: 2023 included visions and feasibility work, followed by work on technical requirements during 2024-36. It is expected that the first implementation specification from 3GPP will be released in 2028 and the first commercial 6G network deployment will be in 2030.

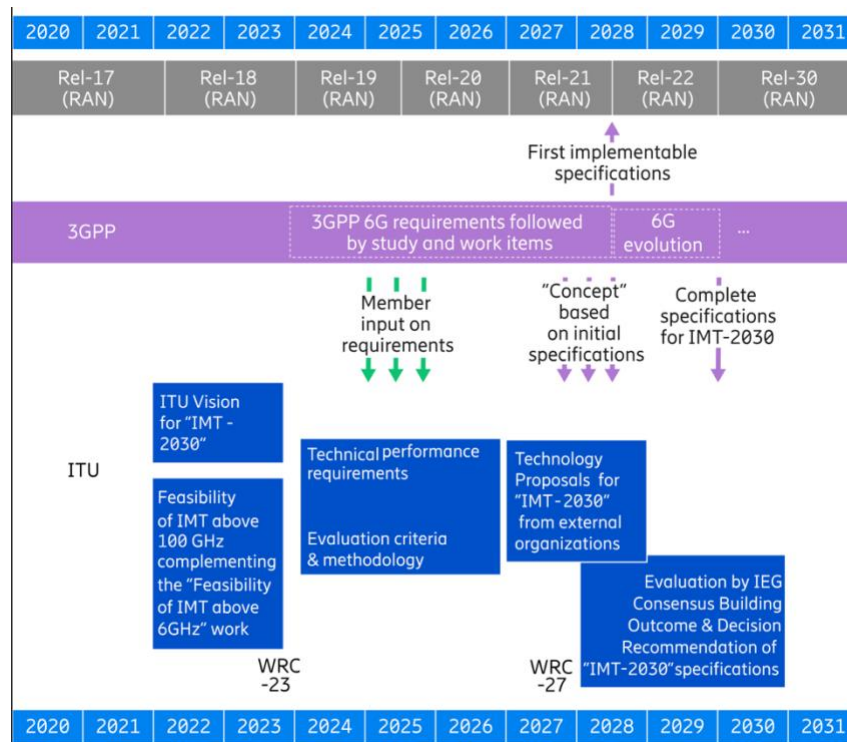

Figure 4: Ericsson proposed ITU-R and 3GPP timeline, simplified view from [ERI-6G-Spectrum].

So, what new capabilities will 6G bring? One improvement traditionally offered by new mobile generations is ~10x data rates. To achieve this, there's much work on securing new spectrum for 6G

³ It should be noted that virtualization is a technology and not an architecture, but since one popular technology choice is to virtualize the CU function, the term virtual RAN is common.

(see [ER-6G-Spectrum] for more details). But 6G is much more than just higher data rates: much work is currently invested in security/trustworthiness, sustainability, and AI/connected intelligence. The EU project Hexa-X (<https://hexa-x.eu>), with the continuation Hexa-X II (see <https://hexa-x-ii.eu>) is looking into these areas, and others in great detail over the next years. Figure 5 summarizes the different capabilities and technical areas described by Hexa-X.

Looking into capabilities such as extreme experience and global service coverage, one can conclude that higher data rates with more antenna locations and lower latencies will be needed with 6G. This then naturally requires higher speed optics in greater volumes and with tightened control of the latency impact.

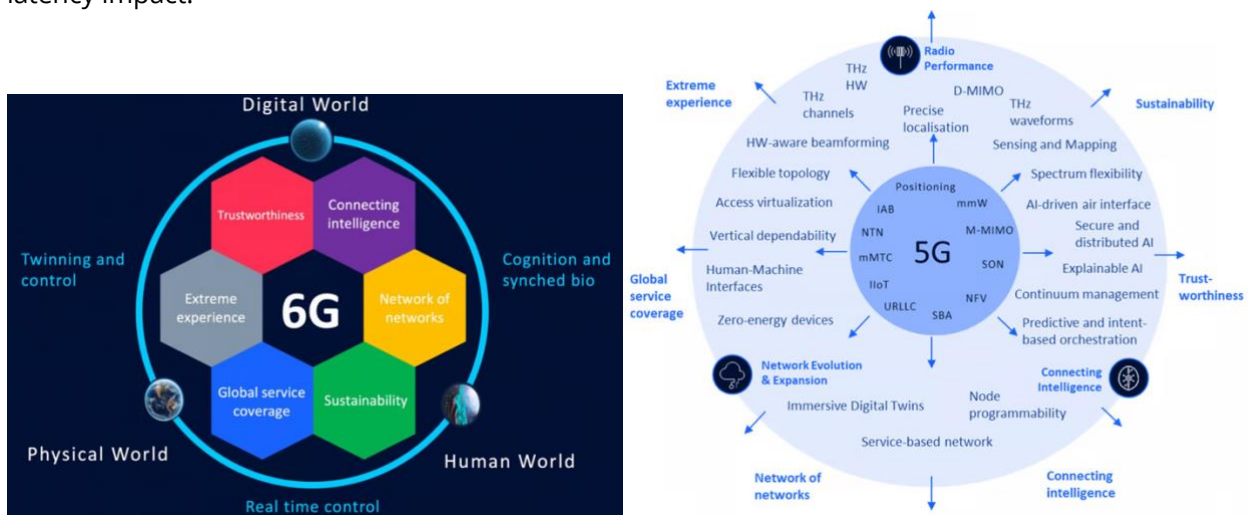

Figure 5: The illustration to the left shows the 6 different capabilities of 6G being addressed by the Hexa-X project and its continuation Hexa-X II. These go along the dimensions of the Human, Physical and Digital worlds. The illustration to the right details technical areas being studied. See [Hexa-X].

Figures 6, 7 and 8 below illustrate the architectures of DRAN. CRAN and virtual RAN, respectively⁴. It should be noted from the below figures:

- The illustrations are greatly simplified. For example, each cell site normally includes multiple RUs.
- All the architectures below have LLS, either locally at the site for DRAN and virtual RAN or spanning sites as in the CRAN case.
- While the below figures explicitly show that DU and CU may be collocated, the illustrations in the rest of this paper may be less explicit. Unless “CU” nodes are explicitly illustrated, the “DU” nodes may include the CU function as well.

⁴ In this paper, the network terms LLS and HLS are used instead of fronthaul, midhaul, x-haul etc., due to the ambition to be unambiguous and to use 3GPP terms whenever possible.

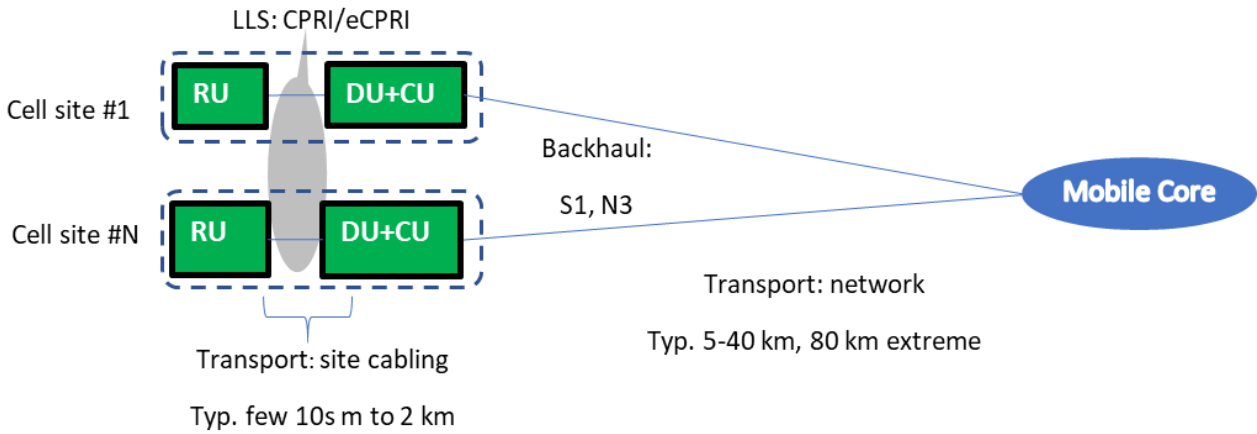

Figure 6: DRAN architecture. The LLS links are highlighted by the gray oval.

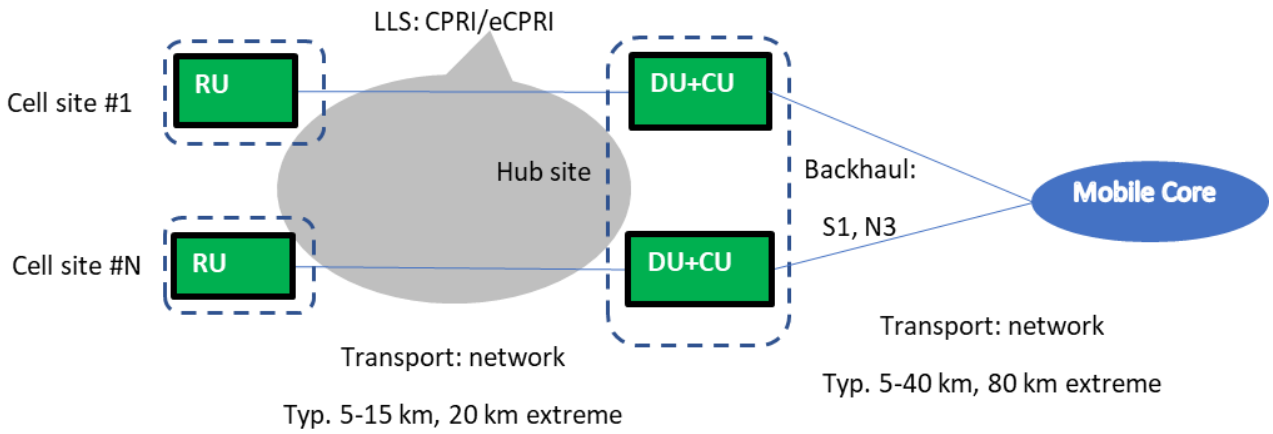

Figure 7: CRAN architecture. The LLS links are highlighted by the gray oval.

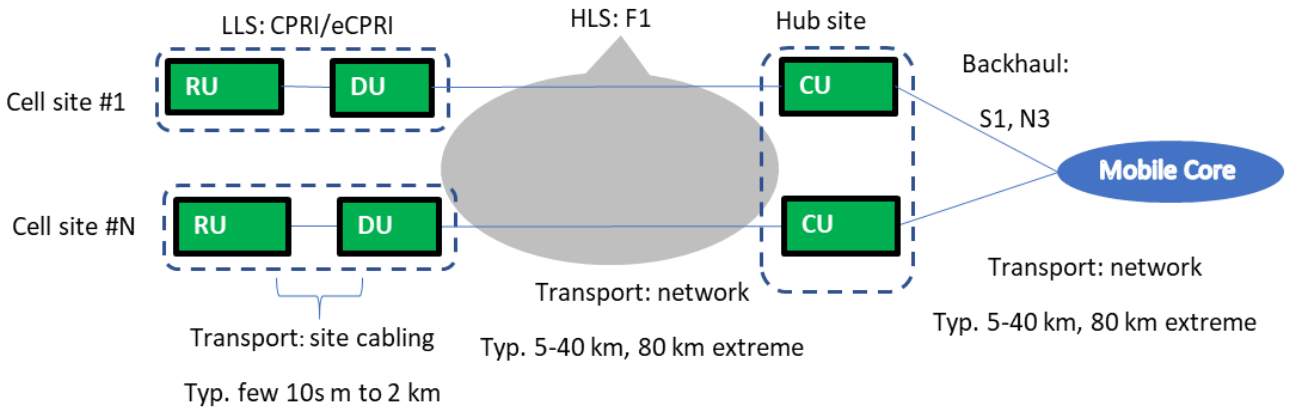

Figure 8: Virtual RAN architecture. The HLS links are highlighted by the gray oval.



6. Generic optical solutions requirements in mobile transport networks

The purpose of this section is to outline the specific requirements characterizing “radio-grade” optical solutions.

6.1. Operating temperature and power consumption classes

In mobile transport networks, optical pluggable modules can be used in RUs or packet nodes that are located outdoors, which requires a wide operating temperature range. While DUs may be deployed in temperature-controlled locations, especially for CRAN, it might be beneficial from an inventory, planning and testing perspective to use wide temperature optical pluggable modules also for DUs. Using wide temperature optics for indoor applications can add cost during the initial phases of the technology and product life cycle, but history and consolidated trends in the industry indicate that this cost addition disappears over time.

The typical requirement for outdoor-grade optical pluggables is the so-called “industrial case operating temperature range”, or “I-temp” for short, ranging from -40 °C to 85 °C. It is identified that a lower bound of -20 °C could provide cost advantages in certain scenarios: the definition of such scenarios and the intended transceiver behavior between -40°C and -20°C case temperature is for further study.

For certain applications with a high density of dissipated power, it could also be necessary to exceed the upper temperature limit, which may require alternative solutions. One such “higher than I-temp” class is very high temp (VHT), which extends the upper limit of I-temp to 95 °C. In this paper, we assume I-temp for all pluggables unless otherwise stated.

Following the methodology described in [OIF-Thermal], we can use the following power consumption classes (PC) which should not be exceeded to facilitate implementation and thermal management on host units.

Form factor	PC 1 [W]	PC 2 [W]	PC 3 [W]	PC 4 [W] ⁵	PC 5 [W]	PC 6 [W]
SFP/+28	1	1.5	2.0	2.5	-	-
DSFP/SFP-DD	1	1.5	2.0	2.5	-	-
SFP56	1	1.5	2.0	2.5	-	-
SFP112	1	1.5	2.0	2.5	5.0	-
QSFP28	1.5	2.0	2.5	3.5	4.0	4.5 ⁶
QSFP-DD	1.5	3.5	7.0	8.0	10	12

Table 2: Power consumption classes (PC) for pluggables, using the methodology in [OIF-Thermal].

The form factors and power classes of Table 2 will be used for the Blueprints outlined in this paper.

⁵ In SFF-8472, the single-lane transceiver power level 4 allows exceeding 2W.

⁶ BiDi DWDM QSFP28 can have up to 7 W power consumption.



Apart from thermal aspects, it's important not to exceed these values because they are used to dimension the electrical power supply of the host boards.

6.2. Power saving mechanisms

Equipment sleep modes are being investigated in the industry and being standardized, for example for radio units (RUs). The resulting implications/requirements for pluggable optics for a RU are not yet clear. What can be said for the optical pluggable is that the total module wake-up time depends on the complexity of the optics, where for today's designs, simpler transmitters without a TEC may require 100s of ms while tunable lasers may require several seconds. Without the optical link, the timing synchronization of the RU cannot be maintained (i.e. holdover times are often practically zero).

6.3. EMI and EMC

EMI and EMC requirements at module level are particularly important, given the possible proximity of optical pluggables to RF receivers: in order to provide enough margin for system-level tests, it's not uncommon to require figures of 6 dB to 12 dB better than the applicable transceiver-level standards in [ETS-EMC] and [FCC15], where FCC Part 15 Class B should be the target on a node level.

6.4. Latency

Particular care must be taken to limit the worst-case latency introduced by the optical pluggable (due to DSP, serialization, FEC encoding and decoding, possibly other manipulations like interleaving). As a general criterion, a contribution to single-ended latency on the order of a few μ s can be tolerated.

6.5. Synchronization

It is also important that potential sources of PTP (Precision Time Protocol) timestamping inaccuracy are tightly controlled. Any effect, deterministic or stochastic, potentially leading to uplink/downlink propagation delay asymmetry, directly impacts the time error budget. The acceptable contribution of pluggables in point-to-point links to overall uplink/downlink delay asymmetry should be less than a few ns. For TDM-PON systems the delay is inherently asymmetric, and this is circumvented by a termination of PTP at the OLT, the use of TPS-TC (Transport Protocol Specific – Transmission Convergence), and generation of PTP at the ONU side.

6.5.1. Impact of optical pluggables on synchronization

In a packet transport network using PTP for synchronization distribution, PTP timestamping inaccuracy must be tightly controlled. Any effect, deterministic or stochastic, potentially leading to uplink/downlink propagation delay asymmetry in a link, directly impacts the time error budget. The acceptable contribution of pluggables in point-to-point links to overall uplink/downlink delay asymmetry should be a small percentage of the overall requirement for the full system. For TDM-PON systems the delay is inherently asymmetric, and this is circumvented by a termination of PTP at the OLT, the use of TPS-TC (Transport Protocol Specific – Transmission Convergence), and



generation of PTP at the ONU side. In the case of TDM-PON the uplink/downlink propagation delays as such are allowed to be different but they must be estimated correctly for a precise distribution of Time of Day to the ONUs.

The MOPA paper “Optical pluggable performance for tight time synchronization” [MOPAsync] presents a detailed description of node level and link level aspects of accurate sync distribution via PTP, and of how the characteristics of optical pluggables can impact them. For this purpose, we propose a classification of delays of optical pluggables. The paper also includes updates related to EEPROM data to estimate propagation delay contribution of a pluggable and propagation delay measurement principles.

6.6. Support of multiple bit rates

The specific nominal bit rates which must be supported are part of the detailed Blueprints descriptions. In general terms, transceivers using internal re-timer ICs are expected to support “re-timer bypass” functions, to allow operation at lower bit rates.

6.7. Form factor standards

The aforementioned form factors are expected to be fully compliant with the relevant SFF MSA specifications in Table 3.

Name	Main specification	Low-speed and general electrical specifications	High-speed electric specification	Common management specification
SFP+	SFF-8083	SFF-8419	SFF-8418	SFF-8472, SFF-8690
SFP28	SFF-8402	SFF-8419	CEI-28G-VSR, IEEE 802.3, 109B.3.2,4	SFF-8472, SFF-8690
SFP56	SFF-8402	SFF-8419	CEI-56G-VSR, IEEE 802.3, 135G.3.2,4	SFF-8472, SFF-8690
SFP112	SFF-8402	SFF-8419	CEI-112G-VSR, IEEE 802.3, Annex 120	ACMIS (abridged CMIS ⁷)
DSFP	DSFP MSA		CEI-28G-VSR	ACMIS (abridged CMIS)
QSFP28	SFF-8665	SFF-8679	CEI-28G VSR, IEEE 802.3 83E.3.2,4	SFF-8636
QSFP-DD	QSFP-DD MSA		CEI-56G VSR, IEEE 802.3 120E.3.2,4	CMIS (common management interface spec)

Table 3: Pluggable form factors and their standards.

The so-called *digital diagnostic monitoring* (DDM) in SFF-8472 and SFF-8636 is very important for observability of optical links, and the *internally calibrated* approach is nowadays almost ubiquitous in line card implementations. No standards exist yet for *remote* DDM, i.e., the possibility to access the DDM of a remote transceiver using the management interface of a local transceiver, using an out-of-band, low bit rate auxiliary communication channel. However, Section 6.11 and Annex B “Remote optical module management” introduces the solutions for remote optical module monitoring with further details in the MOPA Remote Monitoring specification [MOPA-PerfMon]. This work is the basis for MOPA contributions to ITU-T SG15 and SNIA SFF.

⁷ CMIS offers management extensions for wavelength tunability.



6.8. Connectors: UPC, APC

Solutions must be able to work on outdoor fiber plants based on UPC/LC single mode connectors: thus, they must be able to tolerate a maximum discrete optical return loss of -50 dB⁸ [IEC61753]. The only exception to this rule is represented by PON solutions, which can also be based on APC/LC single mode connectors in some cases. Unless stated otherwise in the detailed Blueprints descriptions, UPC/LC single mode connectors are assumed.

6.9. Tunable and automatic self-tunable DWDM pluggables

Currently, DWDM networks utilize either fixed wavelength or wavelength tunable transceivers. It is highly desirable that all DWDM applications described in this document rely on tunable transceivers, for inventory simplification and consequent reduction of the operational costs (no need to label or track fibers, only a single part number is required instead of 48⁹ or 96, easier forecasting and inventory management, less potential for stranded inventory at unused wavelengths). Sub-optimal solutions, where the transceiver can only tune over a subset of wavelengths, can be acceptable as temporary solutions, if the cost gap between full-tunable transceivers and fixed wavelength transceivers remains large.

Self-tunable transceivers add the capability to automatically set the transmission wavelength (*self-tune*) leading to further simplification of network installation and operation practices. This is usually achieved by means of a negotiation procedure between the transceivers at the two ends of the link, exploiting information conveyed through a signaling channel, which can be either in band prior to the start of traffic (e.g., using the same transmission protocol and frame of traffic data) or out of band (e.g., superimposing to the modulating signal an additional amplitude modulation at a low bit rate and low modulation depth). Both solutions have the advantage of being agnostic to the protocol used for transmitting the data (e.g., Ethernet or OTN).

Although customers understand the significant benefits of the self-tune feature, cross-brand units will not inter-operate properly due to the proprietary Self-Tuning Optic (STO) schemes which have been designed and implemented by the various transceiver suppliers. Due to the increasing interest in these features, it is important to identify requirements and propose multi-vendor inter-operable solutions for standardization.

An MSA for STO functionally has been made [SmartT] that enables reduction in OpEx and CapEx:

- Plug and Play feature means less technician time in the field.
 - No need to label or track fibers and no need to buy hundreds of tuning boxes to set the wavelength.
- Only 1 part number is required instead of 96.
 - Easier forecasting and inventory management.
 - Reduces the potential for stranded inventory at the wrong/unused wavelengths.

⁸ It should be pointed out however, that such low values are difficult to assure in field environments, where return loss values of 35 dB are more realistic.

⁹ Used in this paper, reference [G.698.2] specifies a 48 channel 100 GHz grid with min central frequency of 191.4 THz, and max central frequency of 196.1 THz



The self-tuning functionality will not require anything new from the host system and the host system can enable or disable this function.

6.10. Loss budget (channel insertion loss) and chromatic dispersion

In this document we focus on single-mode fiber. Compared to multi-mode fiber, single-mode fiber has clear advantages for the outside plant fiber with its much higher bandwidth-distance product, better tolerance to fiber bends, and lower cable cost. Pluggables for multi-mode fiber can be lower cost than corresponding ones for single-mode fiber, but that cost has historically vanished with volume. Moreover, I-temp tends to be challenging for low-cost multi-mode transmitters. Multi-mode can be interesting for short distance temperature-controlled data center environments. i.e., when using short patch-cords and active cables.

There are many standards for loss budgets, also called channel insertion loss, used in standards documents and the industry. Examples for cabled fiber and splice attenuation include:

- ITU-T G.652 [G.652] Table I.1: Cabled concatenated links incl splices: 0.5 dB/km 1260-1360 nm, 0.275 dB/km 1530-1565 nm
- Commercial example for SMF-28: max 0.35 dB/km 1285-1330nm, max 0.20 dB/km @ 1550 nm (excl. splices).
- ITU-T G.671: Fusion splice active alignment: 0.3 dB.
- ITU-T G.sup39: Cables installed after 2003, Fiber att. average 0.349 dB/km @ 1.3um, 0.205 dB/km @ 1.55um (incl. splices every 2 km).

For connectors (typ. LC assumed in this paper), examples include:

- ITU-T G.671: max 0.5 dB 1260-1360 nm.
- Commercial products: 0.25 - 0.5 dB.

The values above will, in many cases, over-engineer the optics, leading to higher component costs. Instead, this paper suggests a pragmatic approach to find a balance between high quality/reasonable margin and cost: 0.4 dB/km 1260-1360 nm (i.e. O-band), 0.25 dB/km 1530-1565 nm (i.e. C-band), connector loss of 0.5 dB.

We assume there are up to four intermediate connector jumps for distances up to 20 km. For 40 km, since such long links may pass additional flexibility points, we assume up to six connector jumps.

In addition, it is customary for operators to allocate a small margin for maintenance reasons (e.g., degradation of fiber, new splices, bad connectors or minor fiber bends). Consequently, the following loss budget values will be used in this paper:



Distance	Fiber attenuation O-band (1260-1360 nm)	Fiber attenuation C-band (1530-1565 nm)	Connectors Insertion Loss	Maintenance Margin	Total Loss budget - P2P fiber O-band	Total Loss budget - P2P fiber C-band
≤ 2 km	0.8 dB	0.5 dB	2 dB (4x)	0 dB	2.8 dB	2.5 dB
10 km	4 dB	2.5 dB	2 dB (4x)	1 dB	7.0 dB	5.5 dB
15 km	6 dB	3.8 dB	2 dB (4x)	1 dB	9.0 dB	6.8 dB
20 km	8 dB	5 dB	2 dB (4x)	1 dB	11.0 dB	8.0 dB
40 km	16 dB	10 dB	3 dB (6x)	2 dB	20.0 dB *	15.0 dB

Table 4: Loss budget values used in this paper. The total loss budget is sometimes called Channel insertion loss. * The sum of the connector loss and margin is capped at 4 dB.

It should be noted that,

- The above values do not take into account the transmitter and dispersion penalties etc., which are in addition to the loss values for a complete power budget specification. Thus, this paper does not deal with power budget specifications and the related transmitter and receiver requirements.
- The above total loss values are higher than those for IEEE 10GBASE-ER, 25GBASE-ER and 4WDM-40, due primarily to the maintenance margin. For further details, see Appendix A: Referenced Physical layer Standards Exceptions for MOPA Blueprints.

For 10G, we assume a BER of 10e-12, while for 25G and 100G we assume a BER of 5e-5. The latter assumes using FEC with RS(528, 514), i.e., the so-called "KR" FEC. The FEC functionality is implemented in the host system, not in the pluggable.

In some cases, a wavelength mux is required. Commercial values for the insertion loss vary in the range of 4.6 to 6.0 dB depending on the type (AWG vs TFF) and design. For networks that employ a point-to-multipoint fiber infrastructure with passive power-splitting, i.e., a TDM-PON fiber network, the insertion loss of splitters must be added to the insertion loss values indicated for P2P fiber in Table 4.

Nominal wavelength mux and power splitter insertion losses are shown in Table 5 below.

Component	CWDM Mux DeMux 6ch (TFF), Matched Pair	LWDM Mux DeMux 12ch (TFF) matched pair *	DWDM Mux DeMux 48 ch (AWG), Unit	DWDM fixed OADM 6 ch (TFF) Pass / AddDrop, Unit	Power splitter 1:2,4,8,16,32,64
Insertion loss [dB]	4.5	4.5	5.5	0.6 / 3.0	3.5, 7, 10.4, 13.9, 17.4, 21

Table 5: Insertion loss values for passive optical components used in this paper. * Matched pair requires different units on each side. If the same unit is required, the loss per side is 3.5 dB for a total of 7 dB for the pair.



With a similar line of thinking, the value for Chromatic Dispersion (CD) used in this paper is 18 ps/(nm*km) for the C-band and 4 ps/(nm*km) for the O-band. An appropriate Optical Path Penalty (OPP) must be included in the network design to account for the impairments over a fiber distance taken together with any CD mitigation capabilities.

6.11. Lifespan of optical pluggables

Whatever the functional split and the architecture, antenna sites in RAN will remain geographically scattered as they must ensure the intended radio layer coverage. The number of antenna sites and their variety are very large: some antenna sites can be quite difficult and expensive to access, for instance tall cell towers. Geographical distribution of antenna sites also makes spare parts management and logistics an important operational cost. Therefore, lifespan and reliability of optical transceivers for RAN cannot be relaxed to a point where they adversely impact whole network operation costs.

The lifetime of optical transceivers, defined as the period of time for which all requirements must be fulfilled, must be at least 15 years.

During the lifetime, it is also very important that the number of random failures expressed in FITs (number of failures per billion device hours) at high case operating temperatures is very low. If converted from FITs to MTBF and expressed in years, the typical reliability figure required at high case temperature is normally *one order of magnitude larger* than the 'lifetime' figure.

6.12. Remote optical module management

Annex B "Remote optical module management" describes a messaging channel, a frame structure, a memory map, and a protocol that together enable the management of optical modules at the two ends of an optical "black link", either WDM or gray and single or double fiber. The term "black link" means that the internal details of the link are not defined here. In the tunable DWDM case, the requirement for end-to-end operation of the messaging channel is that the two module transmitters are tuned to the correct wavelength(s) so that messages sent by one module's transmitter will be received at the receiver port of the other module.

In the MOPA specification "Remote Performance Monitoring Specification v1.0" [RemMon], a method of sending remote performance monitoring data using the ITU-T G.698.4 frame structure as a basis is defined. A small set of Type of Message is defined for the purpose of sending special messages specifically for SFF-8472 Transceiver Management register device addresses, pages and bytes (inventory and digital diagnostics data mainly). The memory map defined and associated with this specification is detailed in SFF-8472 Rev 12.4.1 and above.

6.13. Firmware update of optical pluggables

There are some cases where the firmware in the EEPROM memory of optical pluggables needs to be updated in the field, for example:

- Error fix. Examples include problems reading diagnostics and laser wavelength misalignment due to inaccurate look-up table values in the memory to account for aging the laser.



- New Standard (e.g. SFF) revisions with new functionality and/alignment with host software revisions.

There are two distinct cases of firmware updates:

- In the case of optical pluggables in a DU, firmware updates could be considered to be done locally in the sense that they are done in a relatively controlled environment with easy access to manual intervention if anything goes wrong.
- In the case of optical pluggables in a RU, firmware updates could be considered to be done remotely in the sense that the locations are often more difficult and costly to visit in case of problems.

From a system vendor perspective,

- Remote in-service firmware updates are typically not supported due to risk of high costs in case of failures (site visits, mast climes, network downtimes etc.). A safer approach is to view the firmware as part of the optical pluggable.
- A module firmware modification will void existing type approvals and respective equipment operation certificates/warranties.

6.14. Optical module system vendor qualification, interoperability and the role of MOPA

System vendors of network equipment, such as RAN and transport equipment, need to ensure the network and system function and performance during the agreed life span – from contractual and/or public relations and/or critical infra perspectives. This also includes pluggable optics being an integral part of the overall system. For an optical pluggable to function as intended in a system/box a number of qualification tests must be met:

1. Meet the applicable available standards and specifications.
2. Fulfill additional functionality not standardized.
3. Module performance is consistent over subcomponent and design changes.
4. Unit variability (i.e. by tests, quality control and audits confirm the module performance variation due to component and manufacturing variation).
5. Function as intended with the specific system/box for that specific network function and deployment type(s).

An industry effort such as MOPA feeds into 1 and 2 above, and in the case of MOPA, specifically for mobile optical pluggables. Areas 3 and 4 above require a continuously adapting testing organization, which is outside the scope of MOPA. Number 5 requires system vendor expertise, continuously evolving with new products and features.

There is a common misconception/expectation that industry work and documentation, such as MOPA and other industry organizations, can produce specifications that include all the necessary information to qualify any optical pluggable for any system box. The main complication is that the combined host equipment (e.g. RU or DU) and optical pluggable system function and performance, for example regarding EMI, must be tested together for the specific combination. Both host



equipment and optical pluggables have continuous updates to hardware, firmware and software that may impact the combined function and performance. While many combinations may work for the base functionality at room temperature during a limited time, the target for critical infrastructure such as mobile networks, must be that all functionality works for all the environmental conditions it is specified for during its entire life span.

From the above, it is fair to conclude that using “any pluggable for any system” is not feasible in the general case, as integration testing and type approval are essential to guarantee system performance, quality, and stability.

The simple answer to the question “Why can’t I just take any optical pluggable and use it in my system box?” is that one wouldn’t know how well the optical pluggable works for that system box over the intended life span. In case of any problems, the system vendor cannot help troubleshooting the problem since the optical pluggable is unknown with regards to its system related behavior. And to answer the follow-up question of “What should I do if there is a problem with a (by the systems vendor) non-qualified optical pluggable in my system?” The response would be that the first action would be to replace the non-qualified optical pluggable with an optical module qualified by the system vendor since this is helping the system reliability and the system vendor troubleshooting task.

7. Mobile Optical Solution Blueprints for LLS in Distributed RAN (DRAN)

7.1. Overview

DRAN is the original RAN deployment and is the most popular deployment method where the DU and RU are in proximity, often within a cell site. The figure below illustrates a simplified DRAN architecture.

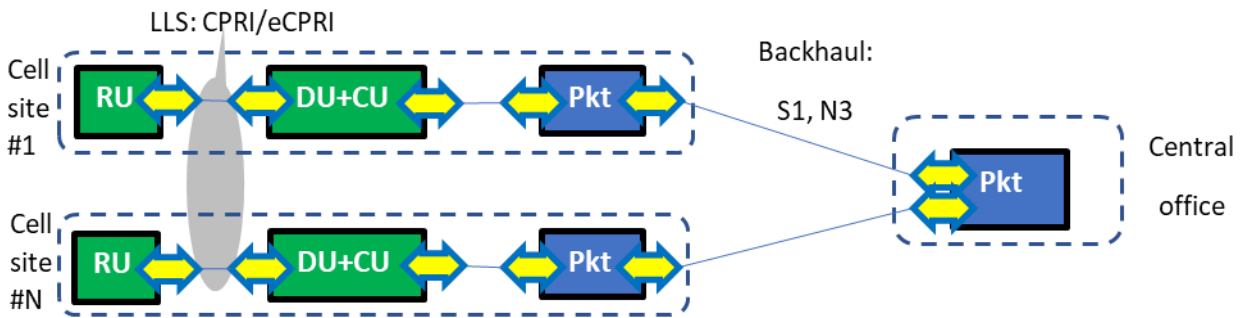

Figure 9: DRAN architecture with RAN nodes, transport nodes and optical pluggables.

Following the above, most of the DRAN DU-RU links are less than 300 m, with a significant number of links extending up to a few kilometers, as shown in Figure 10. .

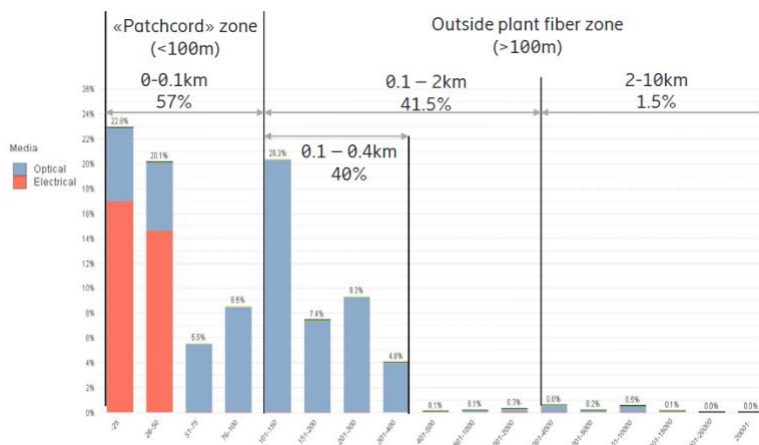

Figure 10: LLS link length distribution.

(source: Ericsson, by characterizing millions of LLS links in live networks).

The typical rooftop installation for macro base stations consists of three radios, with three antennas each covering a 120° sector, to provide omni-directional coverage. This structure is replicated on the same site when several frequency bands have to be supported: for instance, in

4G/LTE a typical deployment is 3x2 (three sectors, two frequency bands). Thus, the number of RU pluggables required at a cell site tends to be a multiple of 3 or 6, with the same for the number of fibers or WDM channels (when used). For 4G/LTE-E deployments, considering typical radio configurations and capacities, the required LLS capacity per sector usually does not exceed 10 Gb/s.

With the adoption of 5G, capacity requirements have increased but the re-architecting of the radio base stations have exposed more bandwidth-efficient LLS transport interfaces, thus limiting the potential explosion of capacity. For 5G NR deployments, considering early radio configurations and capacities, the required LLS capacity per sector usually does not exceed 25 Gb/s today but the adoption of AAS and higher frequency bands will push the required LLS capacity further [GSTR-TN5G].

The two typical scenarios of fiber resources availability in DRAN are reported below:

In the majority of cases, DUs (or DU+CU) are located in close proximity of the RUs (cell towers or rooftop installations) and the fiber interconnect length is relatively short, on the order of few hundred meters: in this scenario not only is the fiber an abundant resource: it is often considered a *consumable* (patch-cords) part of a site cabling solution. Duplex fiber short reach pluggables, which are very cost-effective, can be used.

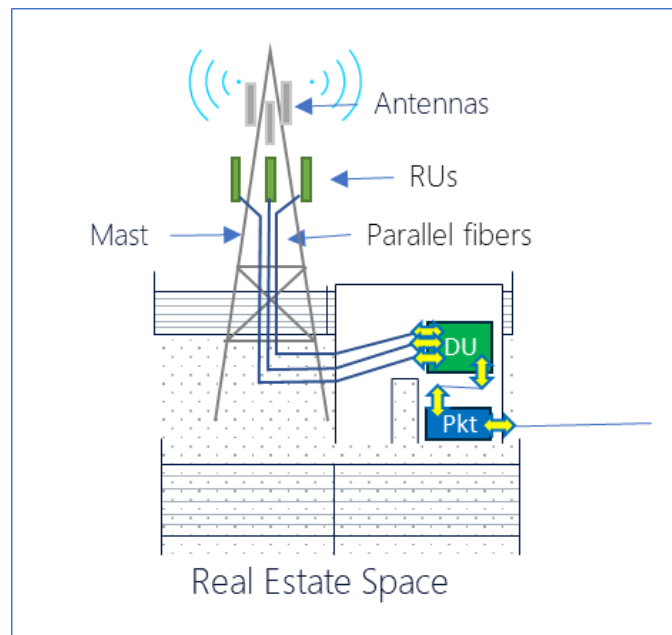

Figure 11: Cell site illustration for the DRAN fiber abundance case.



There are other cases in which the DUs (or DU+CU) and the RUs are not co-located due to for example real estate constraints¹⁰. In these cases, optical patch-cords cannot be used, and dark fiber (typically part of a large cable running in an underground duct) must be used. In this case, it may be beneficial to deploy single-fiber BiDi pluggables, allowing the use/lease of a single dark fiber strand instead of two.

For DRAN deployments, considering the short distance, it is relatively uncommon to find scenarios with a lack of fiber resources. Still, solutions to save fiber count are of interest if the added cost is low, for example BiDi or using fewer higher speed ports rather than multiple ports of lower speeds, daisy-chaining, etc.

10 km is traditionally considered the *shortest distance of interest* for transport networks. However, as is evident from Figure 10, the fiber distances in DRAN deployments are typically much shorter. Reducing the reach requirements may allow reduced costs by using inherently cheaper laser sources. This happened, for instance, with Fabry-Pérot (FP) lasers, creating in LLS the typical “up to 2 km” solution space also seen in ITU-T specs for intra-office and IEEE802.3 for data center interconnects.

It can be noted that even for DRAN where RU and DU equipment is typically collocated resulting in short fiber links, 10 km class optics may still be used, either because the potential shorter class optics devices do not offer any cost advantage (leading the market not to develop or standardize such optics), or that the operator prefers the fewest number of variants, or that the link distance or loss happens to be just too much for 2 km optics. This results in the 7.2.2 blueprint.

Scenarios requiring 10G BiDi are currently covered with 15 km-capable lasers due to the lack of suitable Fabry-Pérot lasers with the proper wavelengths (B2: 1270 nm, 1330 nm). Reach-reduced BiDi pluggables at 25 Gb/s can be achieved by reusing the DFB laser with the proper wavelengths (B2: 1270 nm, 1330 nm), currently in use for 15 km 10 Gb/s BiDi. This is an example of trading fiber reach for extra penalties introduced by the higher speed modulation.

¹⁰ One common example is when the DUs are located in the basement of a building and the RUs on the rooftop of another building, one or more blocks away.

7.2. DRAN Optical Blueprints

7.2.1. 2 km RU-DU direct parallel fibers, dual fiber Blueprint

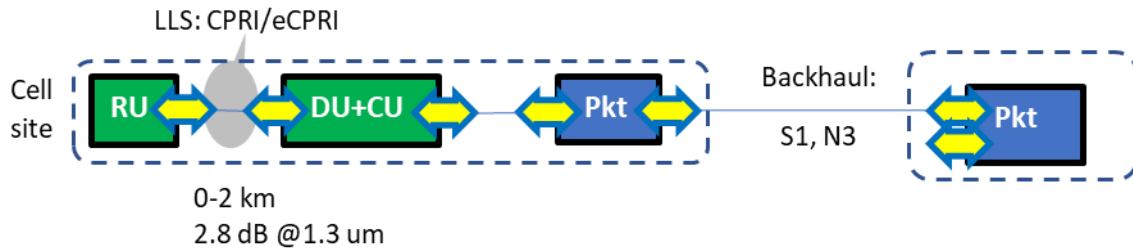

Figure 12: 2 km RU-DU direct parallel fibers Blueprint.

2 km RU-DU Direct parallel fibers Blueprint			
Typical UC	DRAN DU to RU; DU to cell site router intra-site; DU and/or cell site router to microwave element intra-site. Up to 2 km. The BiDi use cases, which are high volume, are covered by 10 km optics (see 7.2.2. blueprint)		
Distance	Typ Min 0 km; Typ. Max: 2 km		
Channel IL	2.8 dB O-band (For typ. max distance)		
Mode, Nr ch., WL	Dual fiber: O-band 1310 nm.		
Temp. Range/Class	I-temp, VHT cases also exist		
Lifespan	15 years		
Data rates	10 Gb/s	25 Gb/s	50 Gb/s
Form factor	SFP+	SFP28	SFP56
FEC, Mod. format	No, NRZ	Yes, NRZ	Yes, PAM4
Power Class	PC2 (1.5 W)	PC2 (1.5 W)	PC2 (1.5 W)
Pluggables codes	10G-2km-O-G-1-2-SFP+	25G-2km-O-G-1-2-SFP28	50G-2km-O-G-1-2-SFP56
Key technologies	-	Low-cost 25G DFB (e.g., reuse 10G 10 km). New low-cost tech like 25G FP.	TBD
Standards	IEEE 802.3, Clause 52	IEEE 802.3, Clause 114	IEEE 802.3, Clause 139
Market status and outlook (*)	Mature	Mature	Introduced

Table 6: 2 km RU-DU direct parallel fibers Blueprint. Following Figure 10, distances up to 2 km are expected to cover a large majority of the deployments.

7.2.2. 10 km RU-DU direct parallel fibers, dual and BiDi fiber Blueprint

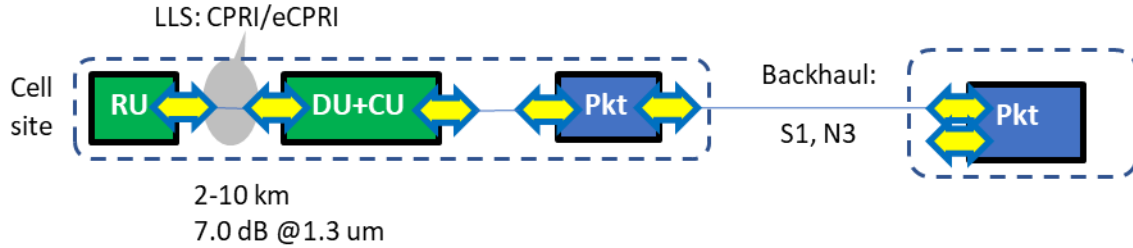

Figure 13: 10 km RU-DU direct parallel fibers Blueprint.

10 km RU DU Direct parallel fibers Blueprint			
Typical UC	DRAN DU to RU. 2-10 km. (This blueprint covers that case when 2 km optics is not available or preferred, or does not meet the distances and/or loss requirements even for short DRAN links)		
Distance	Typ Min 2 km; Typ. Max: 10 km		
Channel IL	7.0 dB O-band (For typ. max distance)		
Mode, Nr ch., WL	Dual fiber: O-band 1310 nm. BiDi O-band 1270nm/1330 nm.		
Temp. Range/Class	I-temp		
Lifespan	15 years		
Data rates	10 Gb/s	25 Gb/s	50 Gb/s
Form factor	SFP+	SFP28	SFP56
FEC, Mod format	No, NRZ	Yes, NRZ	Yes, PAM4
Power Class	PC2 (1.5 W)	PC2 (1.5 W)	PC2 (1.5 W)
Pluggables codes	10G-10km-O-G-1-2-SFP+ 10G-10km-O-B2-2-1-SFP+	25G-10km-O-G-1-2-SFP28 25G-10km-O-B2-2-1-SFP28	50G-10km-O-G-1-2-SFP56 50G-10km-O-B2-2-1-SFP56
Key technologies	-	Low-cost 25G DFB	TBD
Standards	IEEE 802.3, Clauses 52 & 158 ITU-T G.9806 (Amend 2) See Appendix A Tables 5,6,7	IEEE 802.3, Clause 114 & 159 ITU-T G.9806 (Amend 2) See Appendix A Tables 5,6,7	IEEE 802.3, Clauses 139 & 160 ITU-T G.9806 (Amend 2) See Appendix A Tables 5,6,7
Market status and outlook	Mature	Mature	Introduced

Table 7: 10 km RU-DU direct parallel fibers Blueprint. (*) For DRAN, distances between 2 and 10 km are expected to be much fewer than those ≤ 2 km.

8. Mobile Optical Solution Blueprints for LLS in Centralized RAN (CRAN)

8.1. Overview

Centralization of DUs to a single common location drives the need to cover longer fiber distances to connect with the RUs: typical values span for a few kilometers up to 20 km. Specifically, the majority of cases will be below 10 km, almost all below 15 km, and very few cases up to 20 km.

Figure 14 depicts the centralization of the DU and optionally the CU to a hub site. It should be noted that there are three conceivable categories of solutions involving the presence/absence of transport equipment at each end. These are:

1. Active-Active: there is transport equipment at both ends (e.g., Cell site #1)
2. Semi-Active: there is transport equipment only at the hub location. At the cell site, the optical module is plugged directly into the RU (e.g., Cell site #2)
3. Passive-Passive: there is no transport equipment. The optical modules are plugged directly into the RAN equipment at both extremity (e.g., Cell site #3).

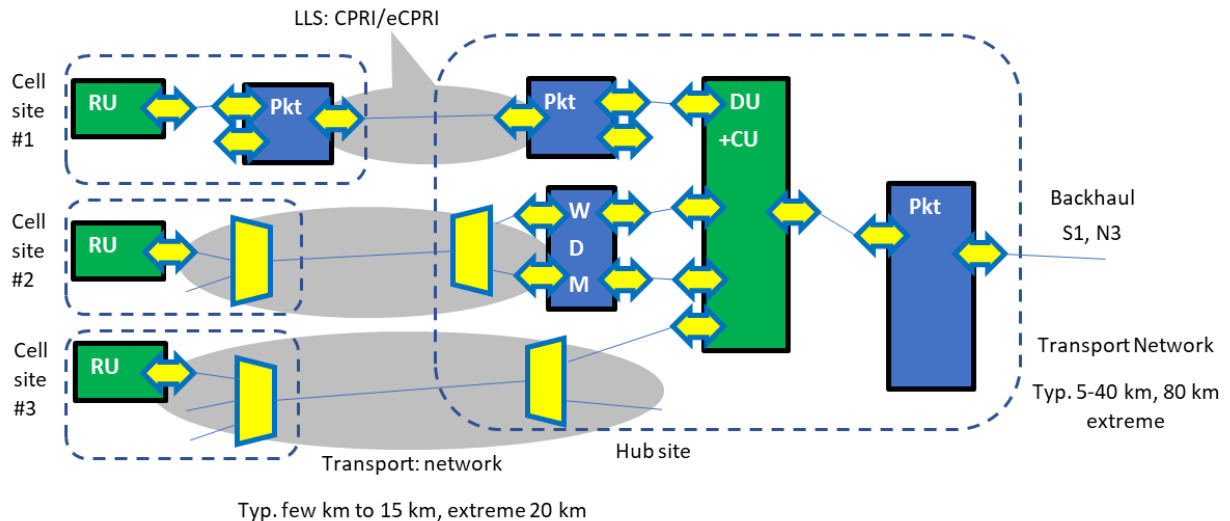

Figure 14: CRAN architecture with RAN nodes, transport nodes and optical pluggables. Cell site #1 shows a case with packet aggregation, Cell site #2 shows a case with semi-active WDM, and Cell site #3 shows a case with passive WDM aggregation.

In CRAN, the site cabling scenario (described for DRAN), which can be solved with optical patch-cords, is clearly not applicable: instead, an installed fiber plant must be used. Availability of fibers varies greatly with the region and the local policies and market regulations.

There are scenarios in which fiber can be considered a relatively abundant resource, for example, in cases where the network operator also owns fiber assets, or because the cost for leasing fiber



resources from third parties is relatively low. In other scenarios, typically in dense urban areas and in unregulated markets, fiber is a scarce resource with high value: its lease costs can be high, driving fiber-lean solutions.

Duplex fiber solutions are used in the “fiber abundance” cases and when the cost of fiber is low. However, in many cases it is very attractive to use optical BiDi pluggables to reduce the number of fibers by two vs dual fiber pluggables.

When the fiber reduction enabled by BiDi is not enough, a way to effectively use fiber resources is to use WDM technologies. There are three main technologies used in fronthaul, with different techno-economic characteristics. CWDM is particularly successful in scenarios where chromatic dispersion is not a big problem, i.e. for low bit rates (<10G) or if the grid is limited to the six O-band wavelengths closer to the zero-dispersion region of fiber. DWDM in C-band, with 100 GHz spacing, is a better choice when scalability to 48 wavelengths is required, up to 25 Gb/s per wavelength; chromatic dispersion management becomes the key issue for scaling to higher capacity per wavelength. LAN-WDM or LWDM, 12 wavelengths with 800 GHz spacing in the O-band, is emerging as an interesting option in the middle: more scalable than O-band CWDM but less than C-band DWDM, less issues with chromatic dispersion as the wavelengths are much closer to the zero-dispersion region of fiber. Different fiber scarcity scenarios and different requirements on maximum distance/maximum bit rate can make one of the three options particularly preferable.

There are, conceptually, two flavors of WDM transport, one that uses a wavelength mux as the branching node in the field and one that uses a power splitter in the field [G989].

- WR-WDM: the first is the more prominent solution and is referred to as Wavelength Routed (WR) since the downstream wavelengths are routed by the wavelength mux at the branching node. There are a number of standardization efforts for this generic architecture (e.g., ORAN, ITU-T SG15 Q6 and ITU-T SG15 Q2 [G.989.x] and [G.9802.x])). Blueprints for this option are presented in Sections 8 and 9.
- WS-WDM: the second is being explored by some operators and is referred to as a Wavelength Selected (WS) because the desired downstream wavelength must be selected by the end node from among all the wavelengths arriving at that point. Some standardization work has been done on this architecture by ITU-T SG15 Q2 [G.989.x] but it is not a mainstream solution at this point. The option will be described in section 12 as a solution that is under evaluation for the future.

NOTE: In some circles, the term PON (Passive Optical Network) is used to describe any point to multi-point architecture that involves a passive branching node, whether that is a Wavelength MUX or a Power Splitter. TDM-PON is the most common form of PON, but it is not the only type of PON. There can also be TWDM-PON and WDM-PON in which the users share a time slot, a wavelength or a combination of the two. Under this definition, the above two architectures would be referred to as a WR-WDM-PON and a WS-WDM-PON. These terms are commonly used in fiber access circles but not necessarily elsewhere, so this note is for background information.



A final observation should be made regarding the architectures that use WDM. In fact, the branching node (whether Wavelength Mux or Power Splitter) can be located at either the cell site or at some other location in the fiber access outside plant. Both alternatives are possible, even though the illustrations may show one location or the other. The location does not affect the functionality.

Packet aggregation enables the use of high-speed gray optics to reduce the fiber count. Single fiber BiDi high bit rate interfaces couldn't be designed in a cheap and simple way in the era of 4x25 Gb/s-based 100 Gb/s implementation, but the rise of single lambda 100 Gb/s solutions paved the way for simple BiDi (e.g., 1270 nm/1310 nm) single fiber implementations.

The combination of high bit rates and wavelength division multiplexing provides a route to scale capacity, for cases where it is not possible to meet the requirement of the number of fiber resources with BiDi optics. Today, coherent pluggables are not cost-optimized for use in CRAN, but direct-detect alternatives are few and their limited performance is placing more demands on the optical infrastructure: the definition of cost reduction opportunities for coherent pluggables should be addressed by new industrial agreements. The same 100G+ bit rate solutions will of course, also be useful to support future capacity growth in DRAN.

8.2. Evolution of WDM systems over different bands

As the capacity needs increase and more and more RUs are added to cell sites, the use of new bands in addition to the C-band used currently by DWDM (see e.g. Blueprint 8.3.3 below) is being investigated (see e.g. Annex A).

A common obstacle to adding new bands is the installed base of WDM multiplexers. However, as an example shown in Annex A Figure ANA.1, the use of WDM multiplexers with expansion ports allows the flexibility¹¹ of adding new bands as the need arises. For example, adding O-band DWDM to an existing LAN-WDM link, adding O-band DWDM to existing C-band DWDM link, or vice versa, and so on.

8.3. CRAN Optical Blueprints

Notes to below blueprints:

Note 8.3.1: Using DWDM to solve fiber scarcity for CRAN is common. Higher rates are not expected to be needed before 2024. Full tunable DWDM has benefits (see sect 6.9) but fixed DWDM may be used if preferred due to module cost.

Note 8.3.2: 15 km optics may not be available for BiDi, dual fiber or both. If so, 20 km optics is used.

¹¹ This type of flexibility is here discussed for non-amplified links typical for mobile network applications.

8.3.1. 15 km RU – DU direct parallel fibers, dual and BiDi fiber Blueprint

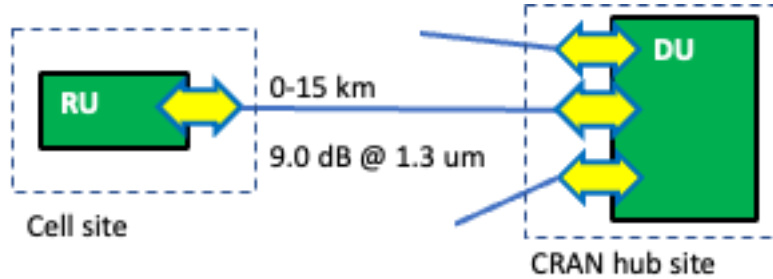

Figure 15: 15 km RU-DU direct parallel fibers Blueprint. Note 8.3.2

15 km RU DU Direct parallel fibers Blueprint			
Typical UC	CRAN DU to RU		
Distance	Typ Min 0 km; Typ. Max: 15 km (Note 8.2.3)		
Channel IL	9.0 dB O-band (For typ. max distance)		
Mode, Nr ch., WL	Dual fiber: O-band 1310 nm. BiDi O-band 1270nm/1330 nm.		
Temp. Range/Class	I-temp		
Lifespan	15 years		
Data rates	10 Gb/s	25 Gb/s	50 Gb/s
Form factor	SFP+	SFP28	SFP56
FEC, Mod. format	No, NRZ	Yes, NRZ	Yes, PAM4
Power Class	PC2 (1.5 W)	PC2 (1.5 W)	PC2 (1.5 W)
Pluggables codes	10G-15km-O-G-1-2-SFP+ 10G-15km-O-B2-2-1-SFP+	25G-15km-O-G-1-2-SFP28 25G-15km-O-B2-2-1-SFP28	50G-15km-O-G-1-2-SFP56 50G-15km-B2-2-1-SFP56
Key technologies	-	Low-cost 25G DFB	TBD
Standards	IEEE 802.3, Clause 158 See Appendix A Tables 9,10	IEEE 802.3, Clause 159 See Appendix A Tables 9,10	IEEE 802.3, Clause 160 See Appendix A Tables 9,10
Market status and outlook (*)	Mature	Mature	Introduced

Table 8: 15 km RU-DU direct parallel fibers Blueprint. For CRAN, the fiber abundance case is a medium size market.

8.3.2. 10 km RU - DU, passive CWDM over a single fiber Blueprint

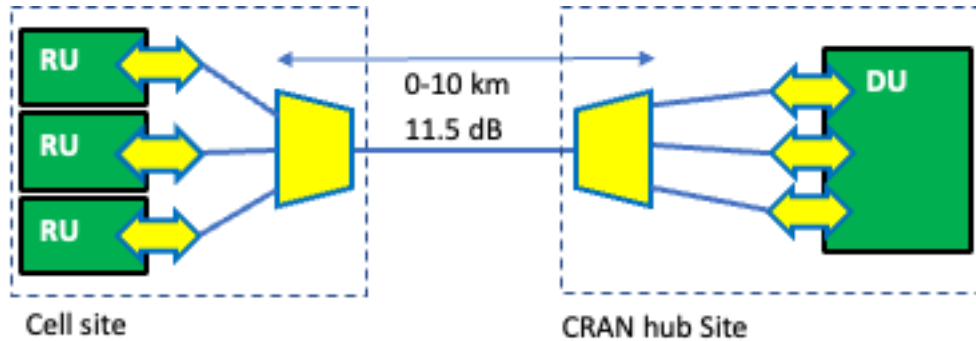

Figure 16: 10 km RU-DU CWDM passive wavelength multiplexed, P2P or P2MP Blueprint.

10 km RU-DU CWDM Blueprint		
Typical UC	CRAN DU to RU. Up to 10 km CWDM P2P or P2MP links up to 3 SFP+ pairs using the same single trunk fiber	
Distance	Typ Min 0 km; Typ. Max: 10 km	
Channel IL	7.0 dB O-band for the fiber (for typ. max distance), 4.5 dB per WDM mux/demux pair: Total 11.5 dB	
Mode, Nr ch., WL	Dual fiber pluggables, single fiber trunk: Wavelength pairs (DU/RU): 1271/1291, 1311/1331, 1351/1371 nm (i.e. the six shortest wavelengths from [G.694.2])	
Temp. Range/Class	I-temp	
Lifespan	15 years	
Data rates	10 Gb/s	25 Gb/s
Form factor	SFP+	SFP28
FEC. Mod format	No, NRZ	Yes, NRZ
Power Class	PC3 (2.0 W)	PC3 (2.0 W)
Pluggables codes	10G-10km-*-C-6-2-SFP+	25G-10km-*-C-6-2-SFP28
Key technologies	-	
Standards	ITU-T G.695. See Appendix A Table 12	
Market status and outlook (*)	Mature	Mature, complements 10G

Table 9: 10 km RU-DU CWDM Blueprint.

8.3.3. 15 km RU – DU, passive LWDM over a single fiber Blueprint

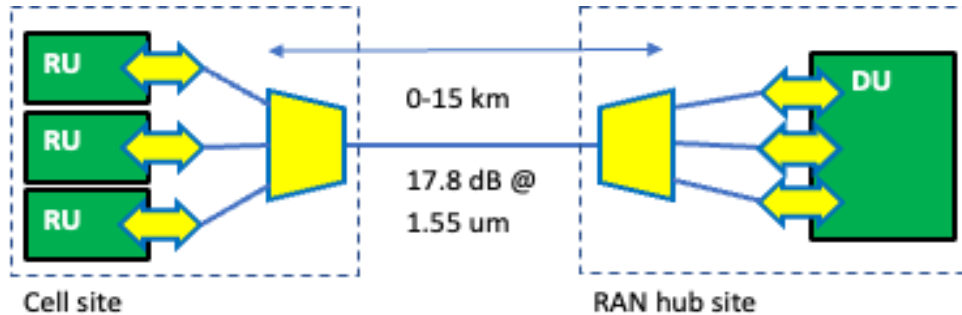

Figure 17: 15 km RU-DU LWDM passive wavelength multiplexed, P2P or P2MP Blueprint

10 km RU-DU CWDM Blueprint		
Typical UC	CRAN DU to RU. Up to 15 km LWDM P2P (all RUs at the same location together with the optical multiplexer) links up to 12 pluggable pairs using the same single trunk fiber.	
Distance	Typ Min 0 km; Typ. Max: 15 km	
Channel IL	9 dB O-band for the fiber (for typ. max distance), 3.5 dB for WDM mux/demux filters: Total 16 dB (same variant filter are assumed but also matched filters are possible, 4.5 dB per pair)	
Chromatic Dispersion	-81.5 to +25 ps/nm	
Mode, Nr ch., WL	Dual fiber pluggables, single fiber trunk: 12 wavelengths @ 800GHz (4.5 nm) spacing	
Temp. Range/Class	I-temp	
Lifespan	15 years	
Data rates	10 Gb/s	25 Gb/s
Form factor	SFP+	SFP28
FEC. Mod format	No, NRZ	Yes, NRZ
Power Class	PC3 (2.0 W)	PC3 (2.0 W)
Pluggables codes	10G-15km-O-L-12-2-SFP+	25G-15km-O-L-12-2-SFP28
Key technologies	Low-cost EML DWDM, without wavelength lockers. Athermal TFF filters	
Standards	ITU-T G.698.5 (formerly G.OWDM) , Tables 8.2 and 9.1	
Market status and outlook (*)	Emerging	Emerging

Table10: 15 km RU-DU LWDM Blueprint.

8.3.4. 15 km RU-DU, passive DWDM over a single fiber Blueprint

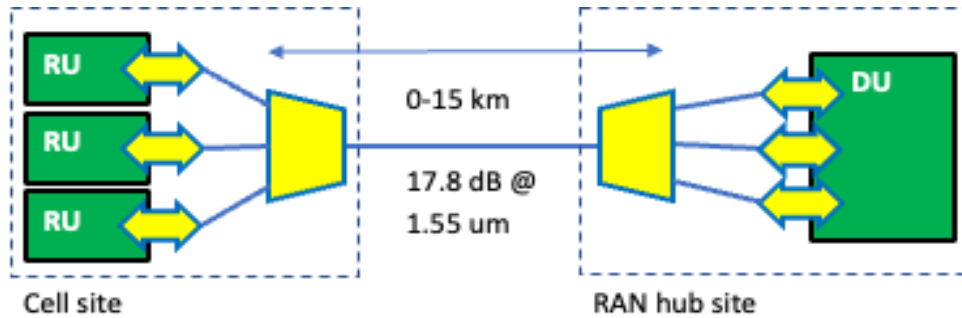

Figure 18: 15 km RU-DU, DWDM passive wavelength multiplexed, P2P or P2MP Blueprint.

15 km RU-DU DWDM Blueprint

Typical UC	CRAN DU to RU. Up to 15 km DWDM P2P (all RUs at the same location together with the optical multiplexer) or P2MP (the RUs are located in slightly different locations, with the optical multiplexer at one of those, or another location) links up to 24 SFP+ pairs using the same single trunk fiber.	
Distance	Typ Min 0 km; Typ. Max: 15 km	
Channel IL	6.8 dB C-band for the fiber (for typ. max distance), 5.5 dB per WDM mux: Total 17.8 dB	
Chromatic Dispersion	270 ps/nm	
Mode, Nr ch., WL	Dual fiber pluggables, single fiber trunk: 48 wavelengths @ 100GHz (0.8nm) spacing	
Temp. Range/Class	I-temp	
Lifespan	15 years	
Data rates	10 Gb/s	25 Gb/s
Form factor	SFP+	SFP28
FEC, Mod format	No, NRZ	Yes, NRZ
Power Class	PC4 (2.5 W)	PC4 (2.5 W)
Pluggables codes	10G-15km-C-D-48-2-SFP+	25G-15km-C-D-48-2-SFP28
Key technologies	Low-cost EML DWDM, without wavelength lockers. Athermal AWG and TFF filters	
Standards	ITU-T G.698.1, Table 8.3. See Appendix A Table 13	-
Market status and outlook (See Note 8.3.1)	Mature	Mature

Table 11: 15 km RU-DU DWDM Blueprint.

8.3.5. 15 km RU-DU, passive DWDM bus over a single fiber Blueprint

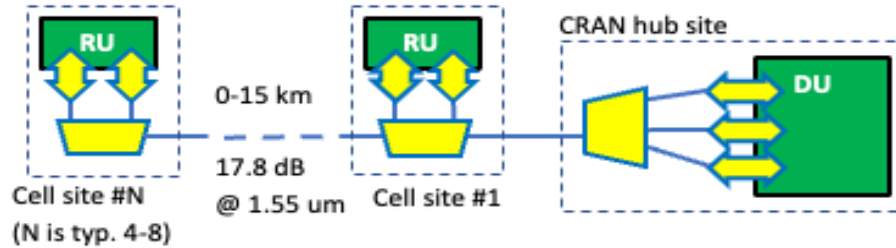

Figure 19: 15 km RU-DU, DWDM passive wavelength multiplexed bus Blueprint.

15 km RU-DU DWDM bus Blueprint		
Typical UC	CRAN DU to radio unit (RU). Up to 15 km DWDM bus or horseshoe topologies with one headend at DU side and multiple add/drop RU sites. Links up to 24 SFP+ pairs using the same single trunk fiber. <ul style="list-style-type: none"> - Flexible use of the available loss budget up to 17.8 dB. (*) - Max number of added/dropped channel at each OADM: 6 - Number of OADMs : Up to 8. (Typical 4-6, deployments with 7-8 are few) 	
Distance	Typ Min 0 km; Typ. Max: 15 km	
Channel IL	6.8 dB C-band for the fiber, 0.6 dB per OADM pass, 3.0 dB for add/drop (up to 8 OADMs (**)): Max total 17.8 dB	
Chromatic Dispersion	270 ps/nm	
Mode, Nr ch., WL	Dual fiber pluggables, single fiber trunk between MUX and OADM: 48 wavelengths @ 0.8nm/100GHz spacing.	
Temp. Range/Class	I-temp	
Lifespan	15 years	
Data rates	10 Gb/s	25 Gb/s
Form factor	SFP+	SFP28
FEC	No	Yes
Power Class	PC4 (2.5 W)	PC4 (2.5 W)
Pluggables codes	10G-15km-C-D-48-2-SFP+	25G-15km-C-D-48-2-SFP28
Key technologies	Low-cost EML DWDM, without wavelength lockers. Athermal AWG and OADM TFF filters.	
Standards	ITU-T G.698.1, Table 8.3. See Appendix A Table 13	-
Market status and outlook (See Note 8.3.1)	Mature (while not very common)	Mature (while not very common)

Table 12: 15 km RU-DU DWDM bus Blueprint. (*) The 17.8 dB value comes from the 8.3.4 Blueprint. Flexible use means that the total loss budget is not calculated as a sum of the fiber and filter losses, but specified as a system limit, that a system design can use a combination of fiber and filter losses up to that value.

8.3.6. 15 km RU-DU, semi-active DWDM over a single fiber Blueprint

This Blueprint is a combination of Blueprints 8.3.3 for the DWDM part, and 7.2.1 for the WDM node to DU optics. In addition to those use cases, this Blueprint offers a WDM demarcation node.

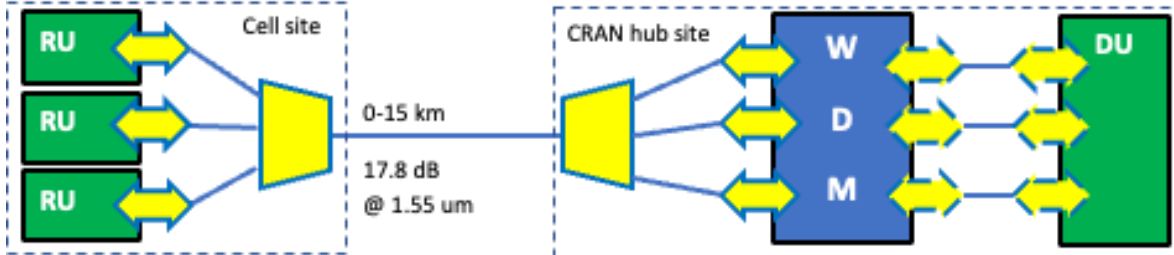

Figure 20: 15 km RU-DU semi-active wavelength multiplexed, P2P or P2MP Blueprint. The intraoffice pluggables at the hub site may be C-temp as indicated by dashed borders.

15 km RU-DU semi-active DWDM Blueprint

Typical UC	CRAN DU to RU. Up to 15 km DWDM P2P (all RUs at the same location together with the optical multiplexer) or P2MP (the RUs are located in slightly different locations, with the optical multiplexer at one of those, or another location) links up to 24 SFP+ pairs using the same single trunk fiber	
Distance	Typ Min 0 km; Typ. Max: 15 km	
Channel IL	6.8 dB C-band for the fiber (for typ. max distance), 5.5 dB per WDM mux: Total 17.8 dB	
Chromatic Dispersion	270 ps/nm	
Mode, Nr ch., WL	Dual fiber pluggables, single fiber trunk: 48 wavelengths @ 0.8nm/100GHz spacing	
Temp. Range/Class	I-temp	
Lifespan	15 years	
Data rates	10 Gb/s	25 Gb/s
Form factor	SFP+	SFP28
FEC, Mod format	No, NRZ	Yes, NRZ
Power Class	PC4 (2.5 W)	PC4 (2.5 W)
Pluggables codes	10G-15km-C-D-48-2-SFP+	25G-15km-C-D-48-2-SFP28
Key technologies	Low-cost EML DWDM, without wavelength lockers. Athermal AWG and TFF filters	
Standards	ITU-T G.698.1, Table 8.3. See Appendix A Table 13	-
Market status and outlook (See Note 8.3.1)	Mature	Mature

Table 13: 15 km RU-DU semi-active DWDM Blueprint. Same table as used for blueprint 8.3.3 for the DWDM part.

8.3.7. 2 km RU-DU packet multiplexing, dual fiber Blueprint

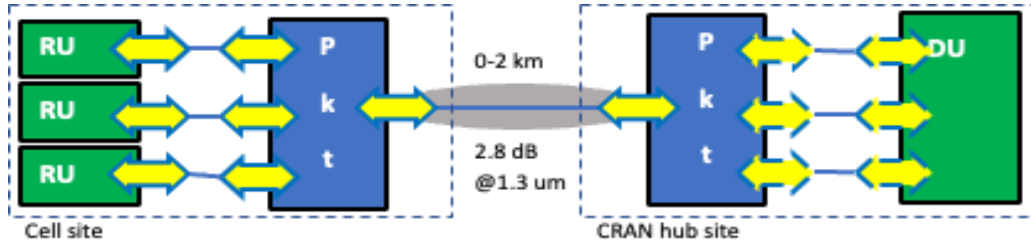

Figure 21: 2 km RU-DU, packet multiplexing, P2P or P2MP Blueprint. The link specified has a gray background. There may be additional intermediate Pkt nodes between the depicted Pkt node and DU, for example on case of cloud RAN deployments at the hub site. The intraoffice pluggables at the hub site may be C-temp as indicated by dashed borders.

2 km RU-DU packet multiplexing Blueprint

Typical UC	DU to RU via packet-multiplexed interconnect, up to 2 km fiber between packet nodes. P2P (all RUs at the same location together with the optical multiplexer) or P2MP (the RUs in slightly different locations, with the packet multiplexer at one of those, or another location). Short reach 10G/25G optical links (<2km, see Blueprint 7.2.1) or direct attach copper cables (DAC) between Pkt node and the corresponding DU/RU.	
Distance	Typ Min 0 km; Typ. Max: 2 km	
Channel IL	2.8 dB O-band (For typ. max distance)	
Mode, Nr ch., WL	Dual fiber: O-band 1310 nm.	
Temp. Range/Class	I-temp	
Lifespan	15 years	
Data rates	25 Gb/s	100 Gb/s
Form factor	SFP28	QSFP28
FEC, Mod. format	No, NRZ	Yes, PAM4 or NRZ for 4WDM
Power Class	PC4 (2.5 W)	PC4 (3.5 W)
Pluggables codes	25G-2km-O-G-1-2-SFP28	100G-2km-O-G-1-2-QSFP28 or 100G-2km-O-C/L-4-2-QSFP28
Key Technologies	-	Low-cost integrated 4x25G WDM or single lambda 100G Tx and Rx.
Standards	IEEE 802.3, Clauses 114	IEEE 802.3, Clause 140 or CWDM4 MSA,
Market status and outlook (*)	Mature	100G 4WDM-10 mature for mobile transport; single lambda 100G ramping

Table 14: 2 km RU-DU packet multiplexing Blueprint. (*) Higher rates (e.g. 400G) are expected in 2024.

8.3.8. 15 km RU-DU packet multiplexing, dual or BiDi fiber Blueprint

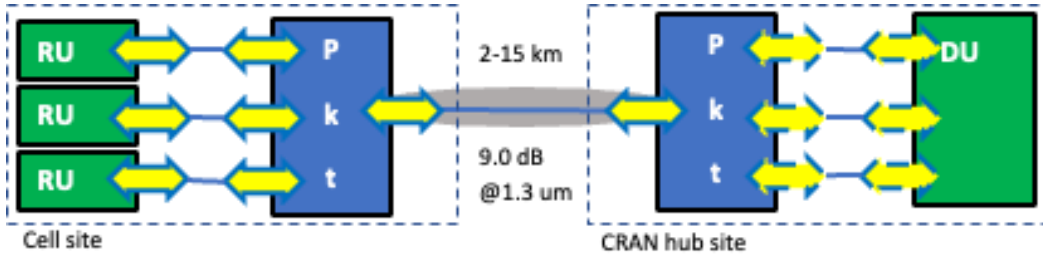

Figure 22: Same as Blueprint 8.3.7 for the 15 km case with dual or bidi fiber.

15 km RU DU packet multiplexed links Blueprint

Typical UC	Same as Blueprint 8.3.7 for the 15 km case with dual or bidi fiber.	
Distance	Typ. Min 0 km; Typ. Max: 15 km (See Note 8.3.2)	
Channel IL	9.0 dB O-band (For typ. max distance)	
Mode, Nr ch., WL	Dual fiber: O-band 1310 nm. BiDi O-band 1270 nm/1330 nm.	
Temp. Range/Class	I-temp	
Lifespan	15 years	
Data rates	25 Gb/s	100 Gb/s
Form factor	SFP28	QSFP28
FEC, Mod. format	Yes, NRZ	Yes, PAM4 or NRZ for 4WDM
Power Class	PC4 (2.5 W)	PC4 (3.5 W)
Pluggables codes	25G-15 km-O-G-1-2-SFP28 25G-15 km-O-B2-2-1-SFP28	100G-15 km-O-G-1-2-QSFP28 or 100G-15 km-O-L-4-2-QSFP28 100G-15 km-O-B2-2-1-QSFP28
Key Technologies	-	Low-cost integrated 4x25G WDM or single lambda 100G Tx and Rx. BiDi: 1270 nm/1330 nm BOSA with single lambda 100G.
Standards	IEEE 802.3, Clause 159. See Appendix A Tables 9.10	100G Lambda MSA or 100G-4WDM-20 MSA, ITU-T G.9806 (Amend 3). See Appendix A Table 11
Market status and outlook (**)	Mature	Dual fiber 100G 4WDM-20 mature for mobile transport; single lambda 100G emerging.

Table 15: 15 km RU-DU packet multiplexing Blueprint. (*) For 100G, 10 km may be more cost-effective, while 15 km is desirable for CRAN LLS deployment cases. (**) Higher rates (e.g. 400G) are expected in 2024.

9. Mobile Optical Solution Blueprints for Backhaul and HLS

9.1. Overview

The mobile backhaul transport network connects the RAN segment with the mobile core segment and has a tiered hierarchical packet aggregation architecture [GSTR-TN5G]. The mobile HLS transport network connects the DUs and the CUs within the RAN. In both cases, the requirements on the transport traffic in terms of latency, delay variance and throughput are less stringent compared with LLS.

The figures below show the overall architectures for backhaul and HLS for DRAN and VRAN, and CRAN. The term *multi-service* is used generically to indicate any type of WDM, packet, TDM, etc., transport network used for different types of services, such as mobile access, enterprise site connectivity, residential connectivity, etc.

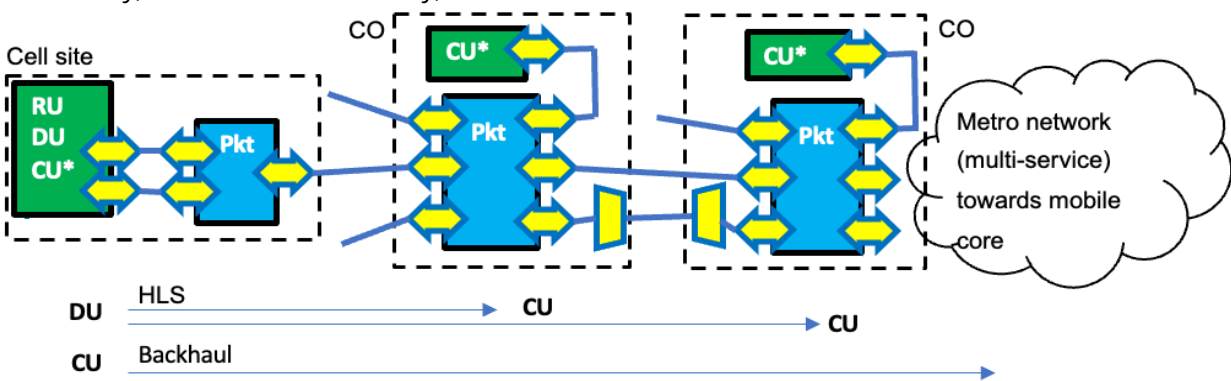

Figure 23: Backhaul and HLS for DRAN and virtual RAN. CU* indicates possible locations for the CU, at the cell site, or at the closest CO. The latter constitutes the VRAN case. The pluggables at the CO sites may be C-temp as indicated by dashed borders for the intraoffice ones.

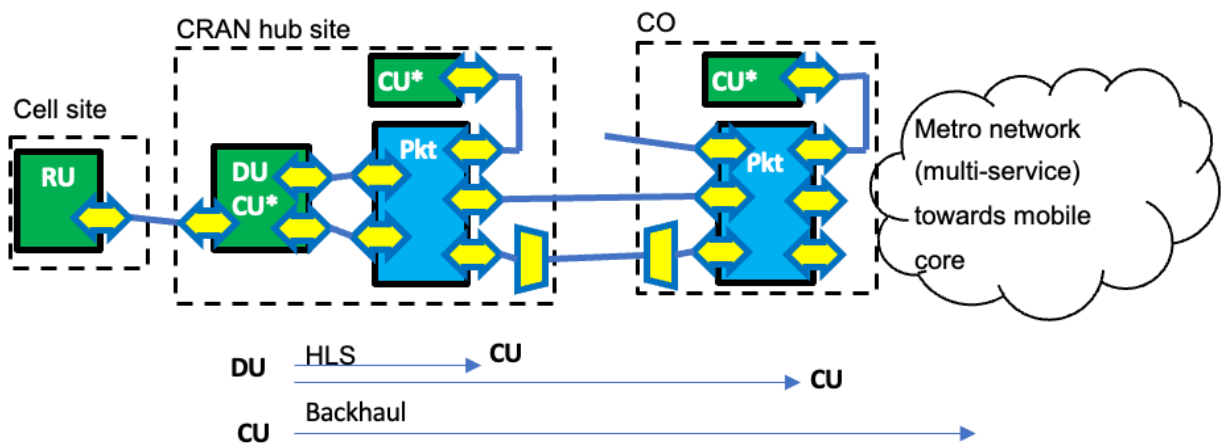

Figure 24: Backhaul and HLS for CRAN. CU* indicates possible locations for the CU, at the CRAN hub site, or at the CO. The latter constitutes the VRAN case. The pluggables at the CRAN hub and CO sites may be C-temp as indicated by dashed borders for the intraoffice ones.



Both DRAN backhaul and CRAN LLS can experience fiber abundance or fiber scarcity in the access part (i.e., between the cell site and the hub site).

When fiber is relatively abundant, it allows for point-to-point parallel fiber links to the individual cell sites, possibly with duplex or BiDi fiber solutions. In scenarios where fiber is more scarce, cost-effective solutions like WDM and TDM-PONs are attractive. TDM-PONs are based on bidirectional use of a common single feeder fiber which is then shared between multiple cell sites by a passive splitter and individual but shorter drop fibers. A single optic in the OLT is shared over multiple ONUs in the cell sites. More information about TDM-PONs and the different standards can be found in [TDM-PON].

This backhaul access network segment, sometimes called *Lo-RAN*, is located between the cell site packet node and the first level of aggregation. See the blueprints in the next section for current data rates.

In the backhaul aggregation segment, sometimes called *Hi-RAN* (*right-hand side of Figs 23 and 24*), which also applies to CRAN backhaul, the typical distances range from 10 km to 40 km, with a non-negligible minority of links demanding even longer reach and different scenarios of fiber resources availability. See the blueprints below for current and future data rates. Presently, unamplified DWDM links at 25G per channel are challenging to make cost-effective beyond 15 km. However, as the technology evolves, there's a need for up to 40 km links as stated above.

Except for the packet nodes at cell sites, other packet equipment is hosted in a temperature-controlled indoor environment, and it is possible to use optical pluggables supporting the so-called *C-temp*, with operating case temperatures in the 0° C to 70° C range.

9.2. Backhaul and HLS Optical Blueprints

9.2.1. 2 km DRAN intraoffice backhaul, direct parallel fibers, dual fiber Blueprint

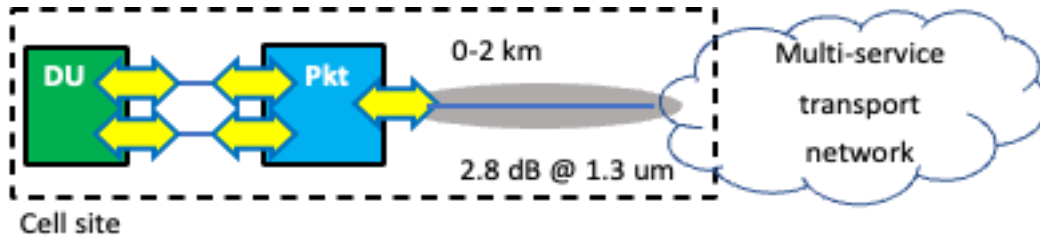

Figure 25: 2 km DRAN intraoffice backhaul direct dual fiber Blueprint. The link specified has a gray background. In cases where the cell site DU is collocated with the CU, backhaul is illustrated. If the CU is located at another location, HLS is illustrated.

2 km intraoffice backhaul Blueprint

Typical UC	DRAN cell site packet node to leased line service, e.g., AAV with local (i.e., box at cell site) demarcation node, providing the transport to the metro transport network.		
Distance	Typ Min 0 km; Typ. Max: 2 km		
Channel IL	2.8dB O-band (For typ. max distance)		
Mode, Nr ch., WL	Dual fiber: O-band 1310 nm		
Temp. Range/Class	I-temp		
Lifespan	15 years		
Data rates	10 Gb/s	25 Gb/s	100 Gb/s
Form factor	SFP+	SFP28	QSFP28
FEC, Mod. format	No, NRZ	Yes, NRZ	Yes, PAM4 or NRZ for 4WDM
Power Class	PC2 (1.5 W)	PC2 (1.5 W)	PC4 (3.5 W)
Pluggables codes	10G-2km-O-G-1-2-SFP+	25G-2km-O-G-1-2-SFP28	100G-2km-O-G-1-2-QSFP28 or 100G-2km-O-C-4-2-QSFP28
Key technologies	-	Low-cost 25G DFB	Low-cost integrated 4x25G WDM or "single lambda" 100G Tx and Rx.
Standards	IEEE 802.3 CI 52 See Appendix A Table 1	IEEE 802.3 CI 114 See Appendix A Table 1	IEEE 802.3 CI 140 See Appendix A Table 4
Market status and outlook (*)	Mature and relatively common case	Emerging	Emerging

Table 16: 2 km intraoffice backhaul Blueprint. (*) Higher rates (e.g. 400G) are not expected in the short term.

9.2.2. 10 km DRAN backhaul, direct parallel fibers, dual and BiDi fiber Blueprint

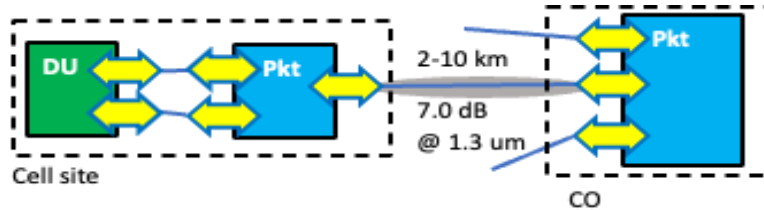

Figure 26: 10 km DRAN backhaul with direct parallel fiber, dual or BiDi Blueprint. The link specified has a gray background. In cases where the cell site DU is collocated with the CU, backhaul is illustrated. If the CU is located at another location, HLS is illustrated.

10 km DRAN backhaul direct parallel fiber Blueprint

Typical UC	DRAN cell site packet node to CO packet aggregation node. In some deployments, the CO side uses a p2p OLT (demarcation point equipment, not shown in the figure above) interfacing the fiber plant.		
Distance	Typ Min 2 km; Typ. Max: 10 km		
Channel IL	7.0 dB O-band (For typ. max distance)		
Mode, Nr ch., WL	Dual fiber: O-band 1310 nm. BiDi O-band 1270nm/1330 nm.		
Temp. Range/Class	I-temp		
Lifespan	15 years		
Data rates	10 Gb/s	25 Gb/s	100 Gb/s
Form factor	SFP+	SFP28	QSFP28
FEC, Mod. format	No, NRZ	Yes, NRZ	Yes, PAM4 or NRZ for 4WDM
Power Class	PC2 (1.5 W)	PC2 (1.5 W)	PC4 (3.5 W)
Pluggables codes	10G-10 km-O-G-1-2-SFP+ 10G-10 km-O-B2-2-1-SFP+	25G-10 km-O-G-1-2-SFP28 25G-10 km-O-B2-2-1-SFP28	100G-10 km-O-G-1-2-QSFP28 or 100G-10 km-O-C/L-4-2-QSFP28 or 100G-10 km-O-B2-2-1-QSFP28
Key technologies	-	Low-cost 25G DFB	Low-cost integrated 4x25G WDM or single lambda 100G Tx and Rx. BiDi: 1270nm/1330nm BOSA with single lambda 100G.
Standards	IEEE 802.3 CI 52 & 158, G.9806 (Amend 2) See Appendix A Tables 5,6,7	IEEE 802.3 CI 114 & 159, G.9806 (Amend 2) See Appendix A Tables 5,6,7.	IEEE 802.3 CI 140 & 88, ITU-T G.9806 (Amend 3) See Appendix A Table 8
Market status and outlook (*)	Mature and relatively common case.	Emerging, complement to 10G.	Few cases but emerging.

Table 17: 10 km DRAN backhaul direct parallel fiber Blueprint. (*) The fiber abundance 10 km case is common for DRAN backhaul.

9.2.3. 40 km DRAN backhaul, direct parallel fibers, dual and BiDi fiber Blueprint

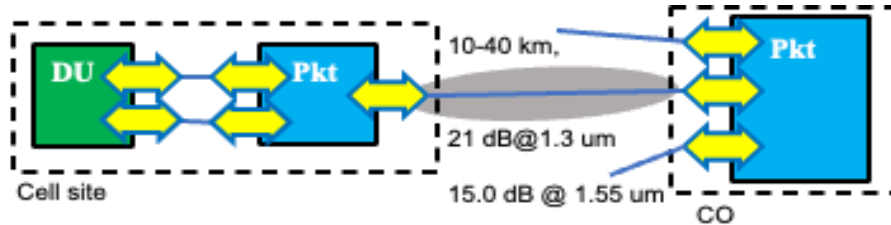

Figure 27: 40 km DRAN backhaul direct parallel fiber, dual or BiDi Blueprint. The link specified has a gray background. In cases where the cell site DU is collocated with the CU, backhaul is illustrated. If the CU is located at another location, HLS is illustrated.

40 km DRAN backhaul direct parallel fiber Blueprint			
Typical UC	DRAN cell site packet node to CO packet aggregation node.		
Distance	Typ Min 10 km; Typ. Max: 40 km (*)		
Channel IL	20.0 dB O-band, 15.0 dB C-band (For typ. max distance)		
Mode, Nr ch., WL	Dual fiber: for 10G: C-band. For 25G and 100G O-band. BiDi O-band 1270nm/1330 nm.		
Temp. Range/Class	I-temp		
Lifespan	15 years		
Data rates	10 Gb/s	25 Gb/s	100 Gb/s
Form factor	SFP+	SFP28	QSFP28
FEC, Mod. format	No, NRZ	Yes, NRZ	Yes, PAM4 or NRZ for 4WDM
Power Class	PC4 (2.5 W)	PC4 (2.5 W)	PC4 (3.5 W)
Pluggables codes	10G-40 km-C-G-1-2-SFP+ 10G-40 km-O-B2-2-1-SFP+	25G-40 km-O-G-1-2-SFP28 25G-40 km-O-B2-2-1-SFP28	100G-40 km-O-G-1-2-QSFP28, or 100G-40 km-O-L-4-2-QSFP28 or 100G-40 km-O-B2-2-1-QSFP28
Key technologies	-	Low-cost 25G EML	Low-cost integrated 4x25G WDM or single lambda 100G Tx and Rx. BiDi: 1270nm/1330nm BOSA with single lambda 100G.
Standards	IEEE 802.3 CI 52 & 158 See Appendix A Tables 14,15	IEEE 802.3 CI 114 & 159 See Appendix A Tables 14,15	100G Lambda MSA, IEEE 802.3 CI 88, ITU-T G.9806 (Amend 3). See Appendix A Tables 14,15
Market status and outlook (**)	Mature and relatively common case.	Emerging, complement to 10G.	Few cases but emerging.

Table 18: 40 km DRAN backhaul direct parallel fiber Blueprint. (*) 40 km is challenging for 25G and 100G. (**) The fiber abundance 40 km case is common (while less than 10 km) for DRAN backhaul.

9.2.4. 15 km DRAN backhaul, passive DWDM bus over a single fiber Blueprint

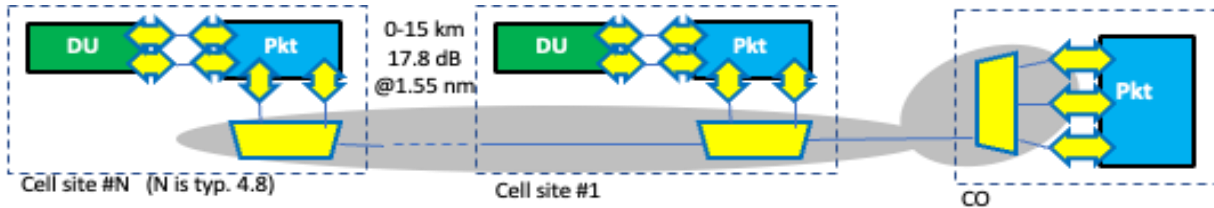

Figure 28: 15 km DRAN backhaul, DWDM passive wavelength multiplexed bus Blueprint. The link specified has a gray background. In cases where the cell site DU is collocated with the CU, backhaul is illustrated. If the CU is located at another location, HLS is illustrated.

15 km DRAN backhaul DWDM bus Blueprint

Typical UC	DRAN cell site packet node to CO packet aggregation. Up to 15 km DWDM bus or horseshoe topologies with headend CO(s) and multiple add/drop cell sites. Up to 24 ch on a single trunk fiber. <ul style="list-style-type: none"> - Flexible use of the available loss budget up to 17.8 dB.(*) - Max number of added/dropped channels at each OADM: 6. - Number of OADMs : Up to 8. (Typical 4-6, deployments with 7-8 are few) 	
Distance	Typ Min 0 km; Typ. Max: 15 km	
Channel IL	6.8 dB C-band for fiber, 0.6 dB per OADM pass, 3.0 dB add/drop (up to 8 OADMs): Max tot. 17.8 dB	
Chromatic Dispersion	270 ps/nm	
Mode, Nr ch., WL	Dual fiber pluggables, single fiber trunk MUX to OADM: 48 wavelengths @ 100 GHz (0.8 nm) spacing.	
Temp. Range	I-temp	
Lifespan	15 years	
Data rates	10 Gb/s	25 Gb/s
Form factor	SFP+	SFP28
FEC, Mod format	No, NRZ	Yes, NRZ
Power Class	PC4 (2.5 W)	PC4 (2.5 W)
Pluggables codes	10G-15 km-C-D-48-2-SFP+	25G-15 km-C-D-48-2-SFP28
Key technologies	Low-cost EML DWDM, without wavelength lockers. Athermal AWG and OADM TFF filters.	
Standards	ITU-T G.698.1 Table 8.3. See Appendix A Table 13	
Market status and outlook (See Note 8.3.1)	Mature.	Maturing but few cases.

Table 19: 15 km DRAN backhaul DWDM bus Blueprint. (*) Same comments for loss budget and flexible use as Blueprint 8.3.4.

9.2.5. 2 km intraoffice CRAN hub site intraoffice backhaul Blueprint

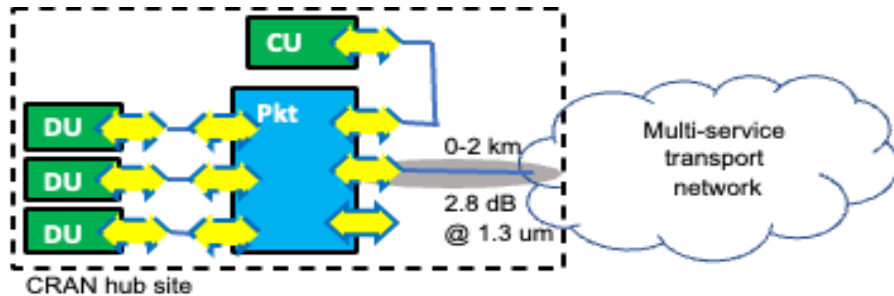

Figure 29: 2 km CRAN hub site intraoffice backhaul direct parallel fiber Blueprint. The link specified has a gray background. In cases where the CU is located at another location, HLS is illustrated. The pluggables at the CRAN hub site may be C-temp as indicated by dashed borders for the intraoffice ones.

2 km intraoffice CRAN hub site intraoffice backhaul Blueprint

Typical UC	CRAN hub site packet node to leased line service, e.g., AAV, with local (i.e., box at cell site) demarcation node, providing the transport to the metro transport network.		
Distance	Typ Min 0 km; Typ. Max: 2 km		
Channel IL	2.8 dB O-band (For typ. max distance)		
Mode, Nr ch., WL	Dual fiber: O-band 1310 nm		
Temp. Range/Class	I-temp (preferred) or C-temp (see section 6.1)		
Lifespan	15 years		
Data rates	10 Gb/s	25 Gb/s	100 Gb/s
Form factor	SFP+	SFP28	QSFP28
FEC, Mod. format	No, NRZ	Yes, NRZ	Yes, PAM4 or NRZ for 4WDM
Power Class	PC2 (1.5 W)	PC2 (1.5 W)	PC4 (3.5 W)
Pluggables codes	10G-2 km-O-G-1-2-SFP+	25G-2 km-O-G-1-2-SFP28	100G-2 km-O-G-1-2-QSFP28, or 100G-2 km-O-C-4-2-QSFP28
Key technologies	-	Low-cost 25G DFB	Low-cost integrated 4x25G WDM or single lambda 100G Tx and Rx.
Standards	IEEE 802.3 CI 52 See Appendix A Table 1	IEEE 802.3 CI 114 See Appendix A Table 1	IEEE 802.3 CI 140 or CWDM4 MSA See Appendix A Table 4
Market status and outlook (*)	Mature and relatively common case.	Emerging, few cases.	Few cases. Port capacities beyond 100G, ie 400G, may be needed in the mid-term, for example with form factors QSFP, QSFP-DD or OSFP or port aggregation".

Table 20: 2 km CRAN hub site intraoffice backhaul Blueprint. (*) Higher rates (400G) are not expected before 2024.

9.2.6. 10 km CRAN backhaul, direct parallel fibers, dual and BiDi fiber Blueprint

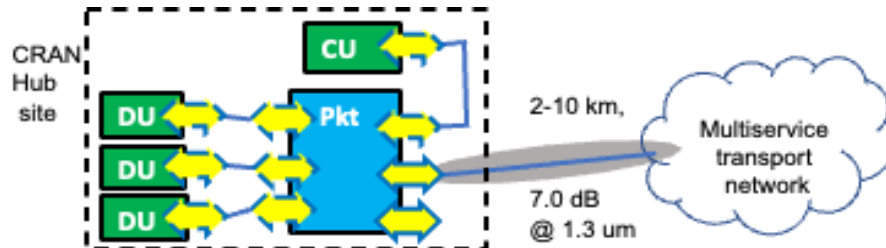

Figure 30: 10 km CRAN backhaul Blueprint (direct P2P, no WDM). The link specified has a gray background. In cases where the CU is located at another location, HLS is illustrated. The pluggables at the CRAN hub site may be C-temp as indicated by dashed borders for the intraoffice ones.

10 km CRAN hub site backhaul direct parallel fiber Blueprint

Typical UC	CRAN hub site Pkt node to Multiservice transport network at another site.		
Distance	Typ Min 2 km; Typ. Max: 10 km		
Channel IL	7.0 dB O-band (For typ. max distance)		
Mode, Nr ch., WL	Dual fiber: O-band 1310 nm. BiDi O-band 1270nm/1330 nm.		
Temp. Range/Class	I-temp (preferred) or C-temp (see Section 6.1).		
Lifespan	15 years		
Data rates	10 Gb/s	25 Gb/s	100 Gb/s
Form factor	SFP+	SFP28	QSFP28
FEC, Mod. format	No, NRZ	Yes, NRZ	Yes, PAM4 or NRZ for 4WDM
Power Class	PC2 (1.5 W)	PC2 (1.5 W)	PC4 (3.5 W)
Pluggables codes	10G-10 km-O-G-1-2-SFP+ 10G-10 km-O-B2-2-1-SFP+	25G-10 km-O-G-1-2-SFP28 25G-10 km-O-B2-2-1-SFP28	100G-10 km-O-G-1-2-QSFP28, or 100G-10 km-O-C/L-4-2-QSFP28 100G-10 km-O-B2-2-1-QSFP28
Key technologies	-	Low-cost 25G DFB	Low-cost integrated 4x25G WDM or single lambda 100G Tx and Rx. BiDi: 1270 nm/1330 nm BOSA with single lambda 100G.
Standards	IEEE 802.3 CI 52 & 158 G.9806 (Amend 2) See Appendix A Tables 5,6,7	IEEE 802.3 CI 114 & 159 G.9806 (Amend 2) See Appendix A Tables 5,6,7	IEEE 802.3 CI 140 & 88, ITU-T G.9806 (Amend 3) See Appendix A Table 8.
Market status and outlook (*)	Mature and relatively common case	Emerging, complement to 10G	Few cases but emerging.

Table 21: 10 km CRAN backhaul direct parallel fiber Blueprint. (*) The fiber abundance 10 km case is common for CRAN backhaul.

9.2.7. 40 km CRAN backhaul, direct parallel fibers, dual and BiDi fiber Blueprint

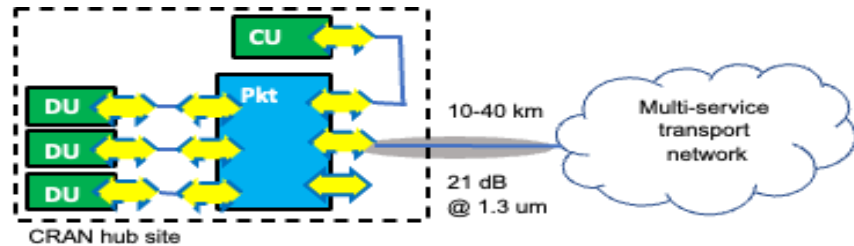

Figure 31: 40 km CRAN hub site backhaul direct parallel fiber Blueprint. The link specified has a gray background. In cases where the CU is located at another location, HLS is illustrated. The pluggables at the CRAN hub site may be C-temp as indicated by dashed borders for the intraoffice ones.

40 km CRAN hub site backhaul direct parallel fiber Blueprint

Typical UC	CRAN hub site Pkt node to Multiservice transport network at another site.		
Distance	Typ Min 10 km; Typ. Max: 40 km (*)		
Channel IL	20.0 dB O-band, 15.0 dB C-band (For typ. max distance)		
Mode, Nr ch., WL	Dual fiber: For 10G: C-band 1.55 um. For 25G and 100G O-band 1.3 um. BiDi O-band 1270nm/1330 nm.		
Temp. Range/Class	I-temp (preferred) or C-temp (see Section 6.1).		
Lifespan	15 years		
Data rates	10 Gb/s	25 Gb/s	100 Gb/s
Form factor	SFP+	SFP28	QSFP28
FEC, Mod. format	No, NRZ	Yes, NRZ	Yes, PAM4 or NRZ for 4WDM
Power Class	PC4 (2.5 W)	PC4 (2.5 W)	PC4 (3.5 W)
Pluggables codes	10G-40 km-C-G-1-2-SFP+ 10G-40 km-O-B2-2-1-SFP+	25G-40 km-O-G-1-2-SFP28 25G-40 km-O-B2-2-1-SFP28	100G-40 km-O-G-1-2-QSFP28, 100G-40 km-O-L-4-2-QSFP28 100G-40 km-O-B2-2-1-QSFP28
Key technologies	-	Low-cost 25G EML.	Low-cost integrated 4x25G WDM or single lambda 100G Tx and Rx. BiDi: 1270 nm/1330 nm BOSA with single lambda 100G.
Standards	IEEE 802.3, CI 52 & 158 See Appendix A Tables 14,15	IEEE 802.3 CI 114 & 159 See Appendix A Tables 14,15	100G Lambda MSA, IEEE 803.3 CI 88 ITU-T G.9806 (Amd 3). See App A Tables 14,15
Market status and outlook (**)	Mature and relatively common case.	Emerging, few cases.	Few cases.

Table 22: 40 km CRAN backhaul direct parallel fiber Blueprint. (*) 40 km is challenging for 25G and 100G. (**) The fiber abundance 40 km case is less common than 10 km for CRAN backhaul.

9.2.8. 15 km CRAN backhaul, passive DWDM over a single trunk fiber Blueprint

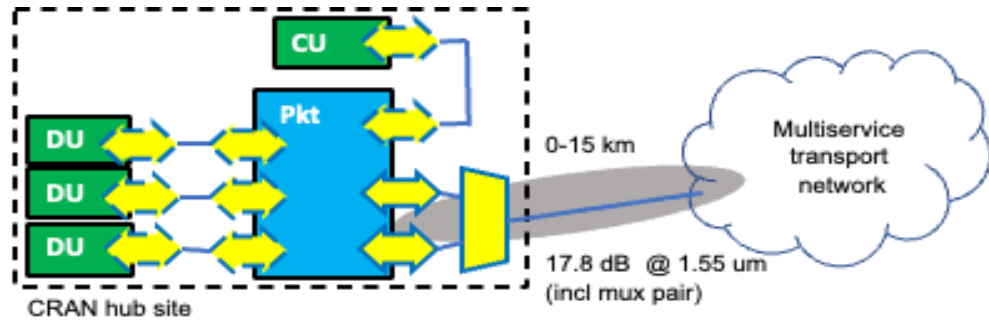

Figure 32: 15 km CRAN backhaul, DWDM passive wavelength multiplexed Blueprint. In cases where the CU is located at another location, HLS is illustrated.

15 km CRAN hub site backhaul DWDM Blueprint

Typical UC	CRAN hub site Pkt node to Multiservice transport network at another site. Up to 15 km DWDM P2P links with up to 24 SFP+ pairs using the same single trunk fiber.	
Distance	Typ Min 0 km; Typ. Max: 15 km	
Channel IL	6.8 dB C-band for the fiber (For typ. max distance), 5.5 dB per WDM mux: Total 17.8 dB	
Chromatic Dispersion	270 ps/nm	
Mode, Nr ch., WL	Dual fiber pluggables, single fiber trunk: 48 wavelengths @ 0.8nm/100GHz spacing	
Temp. Range/Class	I-temp (preferred) or C-temp (see Section 6.1)	
Lifespan	15 years	
Data rates	10 Gb/s	25 Gb/s
Form factor	SFP+	SFP28
FEC, Mod. format	No, NRZ	Yes, NRZ
Power Class	PC4 (2.5 W)	PC4 (2.5 W)
Pluggables codes	10G-15km-C-D-48-2-SFP+	25G-15km-C-D-48-2-SFP28
Key technologies	Low-cost EML DWDM, without wavelength lockers. Athermal AWG and TFF filters.	
Standards	ITU-T G.698.1, Table 8.3. See Appendix A Table 13	-
Market status and outlook (*, See Note 8.3.1)	Mature. Few cases	Few cases

Table 23: 10 km CRAN hub site backhaul DWDM Blueprint. (*) Intra-office, direct fiber cases are more common.

9.2.9. 20 km DRAN Backhaul and HLS with TDM-PON, Separate ONU box Blueprint

A PON system consists of OLT and multiple subtended ONUs. The ONU functionality at the cell site can be provided as a separate ONU box as shown in this Blueprint.

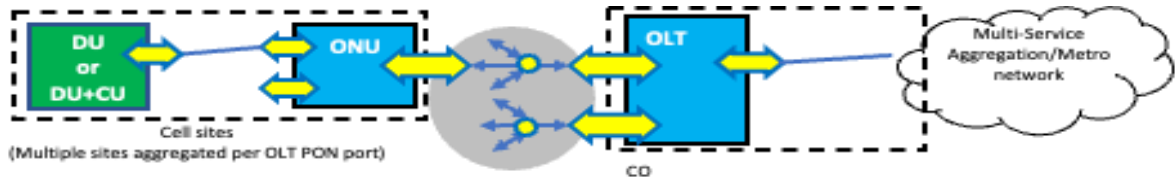

Figure 33: Up to 20 km Backhaul and HLS with TDM-PON using separate ONU box. HLS is depicted in cases where the CU is centralized. Backhaul is depicted in cases where the CU is located at the cell site.

20 km DRAN Backhaul and HLS with TDM-PON, Separate ONU box Blueprint

Typical UC	Transport from small/medium cell site with DU and optionally CU to the multiservice transport network at another site. The separate ONU box can act as a demarcation point, and as an aggregating point at the cell site when having multiple interfaces. For cases where there is available space for an external transport box at the cell site.		
Distance	Typ. Max: 20 km		
Transmission mode	Single fiber (BiDi)		
Temp. Range/Class	I-temp		
Lifespan	15 years		
Data rate Down/Up	GPON: 2.5 / 1.25 Gb/s	XGS-PON, 10G EPON: 10 / 10 Gb/s	25GS-PON, 25G EPON: 25/10 (or 25) Gb/s
Channel IL	B+ (28 dB), C+ (32 dB), C++ (34 dB). Highest Class: D (35 dB).	N1 (29 dB) and N2 (31 dB). Higher classes: E1 (33 dB), E2 (35 dB).	Starting at N1 (29 dB). Higher classes (N2, E1, E2) for longer term.
Wavelength bands	1300-1320 nm Up 1480-1500 nm Down	1260-1280 nm Up 1575-1580 nm Down	Multiple options in the O-band depending on coexistence requirements.
Form factor	SFP, SFP-DD for dual OLT module	SFP+	SFP28
FEC	Yes	Yes	Yes
Power Class	Dual OLT module: PC4 (2.5 W) Single OLT module: PC2 (1.5 W) ONU module: PC2 (1.5 W)	OLT module: PC4 (2.5 W) ONU module: PC3 (2 W)	OLT module: PC4 (2.5 W) ONU module: PC4 (2.5 W), evolution to PC3 (2 W) is desired.
Pluggables codes	GPON-20 km-OS-B3-1-SFP-OLT GPON-20 km-OS-B3-1-SFP-ONU	XGS-PON-20 km-OL-B3-1-SFP+-OLT XGS-PON-20 km-OL-B3-1-SFP+-ONU	25GS-PON-20 km-O-B3-1-SFP28-OLT 25GS-PON-20 km-O-B3-1-SFP28-ONU
Key technologies	BOSA with DML and PIN or APD.	BOSA with EML and APD.	BOSA with EML and APD.
Standards (Phy & MAC)	ITU-T G.984.x See Appendix A Table 16	IEEE 802.3 Cl. 75. ITU-T G.9807.x See Appendix A Table 16	IEEE 802.3 Cl 141. 25GS-PON MSA See Appendix A Table 16
Market status and outlook	Mature, mass deployments for FTTx, volume deployments for 4G	Mature, volume deployments for FTTx, 5G small cell deployments	Emerging technology under validation, future deployments

Table 24: 20 km DRAN Backhaul and HLS with TDM-PON, Separate ONU box Blueprint. (Note: There are also SFP family-based OLT modules combining both XGS-PON and GPON in a single fiber.)

9.2.10. 20 km DRAN Backhaul and HLS with TDM-PON, Pluggable ONU

Instead of an external box, the cell site ONU functionality can be integrated into the pluggable optic (*Pluggable ONU*, also known as *ONU on a stick* or *Integrated ONU (iONU)*).

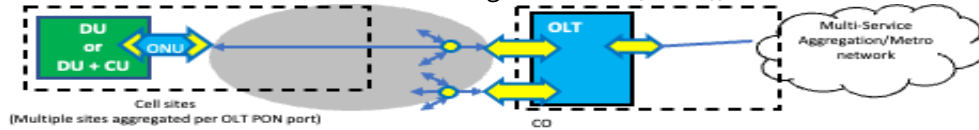

Figure 34: Up to 20 km backhaul and HLS with TDM-PON using pluggable ONU. HLS is depicted in cases where the CU is centralized. Backhaul is depicted in cases where the CU is located at cell site.

20 km DRAN Backhaul and HLS with TDM-PON, Pluggable ONU Blueprint

Typical UC	Transport from small or medium cell site with DU and optionally CU functionality to multiservice transport network at another site. Preferred solution if there is no space for external transport box at cell site.		
Distance	Typ. Max: 20 km		
Transmission mode	Single fiber (BiDi)		
Temp. Range/Class	I-temp		
Lifespan	15 years		
Data rate Down / Up	GPON: 2.5 / 1.25 Gb/s	XGS-PON, 10G EPON: 10 / 10 Gb/s	25GS-PON, 25G EPON: 25 / 10 (or 25) Gb/s
Channel IL	B+ (28 dB), C+ (32 dB), C++ (34 dB), Highest Class D (35 dB)	N1 (29 dB) and N2 (31 dB). High classes E1 (33 dB) and E2 (35 dB)	Starting at N1 (29 dB). Higher classes (N2, E1, E2) for longer term.
Wavelength bands	1300-1320 nm Up 1480-1500 nm Down	1260-1280 nm Up 1575-1580 nm Down	Multiple waveband options in the O-band depending on coexistence requirements.
Form factor	SFP, SFP-DD for dual OLT module	SFP+	SFP28
FEC	Yes	Yes	Yes
Power Class	Dual OLT module: PC4 (2.5 W) Single OLT module: PC2 (1.5 W) integrated ONU module: PC3 (2 W)	OLT module: PC4 (2.5 W) Integrated ONU module: PC4 (2.5 W), evolution to PC3 (2 W) is desired	OLT module: PC4 (2.5 W) Integrated ONU module: TBD.
Pluggables codes	GPON-20 km-OS-B3-1-SFP-OLT GPON-20 km-OS-B3-1-SFP-iONU	XGS-PON-20 km-OL-B3-1-SFP+-OLT XGS-PON-20 km-OL-B3-1-SFP+-iONU	25GS-PON-20 km-O-B3-1-SFP28-OLT 25GS-PON-20 km-O-B3-1-SFP28-iONU
Key technologies	BOSA w. DML and PIN or APD. Pluggable also contains SoC for ONU PON MAC.	BOSA with EML and APD. Pluggable also contains SoC for ONU PON MAC.	BOSA with EML and APD. Pluggable also contains SoC for ONU PON MAC.
Standards (Phy & MAC)	ITU-T G.984.x See Appendix A Table 16	IEEE 802.3 Cl. 75, ITU-T G.9807.x See Appendix A Table 16	IEEE 802.3 Cl 141, 25GS-PON MSA See Appendix Table 16
Market status and outlook	Mature, mass deployments for FTTx, volume deployments for 4G	Mature, volume deployments for FTTx, 5G small cell deployments	Emerging technology under validation, future deployments

Table 25: 20 km DRAN Backhaul and HLS with TDM-PON, Pluggable ONU Blueprint. (Note: There are also SFP family-based OLT modules combining both XGS-PON and GPON in a single fiber.)

10. Cloud RAN optical solutions

This paper is intentionally focused on the optical solutions of mobile networks and not the particular implementations of the RAN functions. However, there are at least two distinct ways to implement baseband (DU with or without CU) equipment: integrated or cloud RAN, where the latter is much less understood from an optical perspective.

Cloud RAN [CloudRAN] is defined as using compute server [server] hardware for DU and/or CU functions, sometimes called vDU and vCU, see the figure below for an example with a vDU. The compute server is equipped with one or more pluggable NICs (Networks Interface Card, [NIC]), typically using either PCIe or OCP interfaces to the server. The NICs host one or multiple optical pluggables. As an example, NIC may have four ports of SFPx / QSFPx..

As can be seen from the figure below, there are several connectivity solutions between the vDU and the RUs, already outlined in previous chapters: parallel dual or bidi gray fibers, packet aggregation and WDM aggregation.

One example of optical performance monitoring is by using ethtool [ethtool], which is a generic tool for linux kernels. The -m command will provide all the content of the SFP EEPROM, including (if supported) the SFP temperature, TX and RX optical powers, etc. Also, the DMFT NC-SI specifications [NC-SI] describes how this info can be obtained, while the specification focus on module temperature.

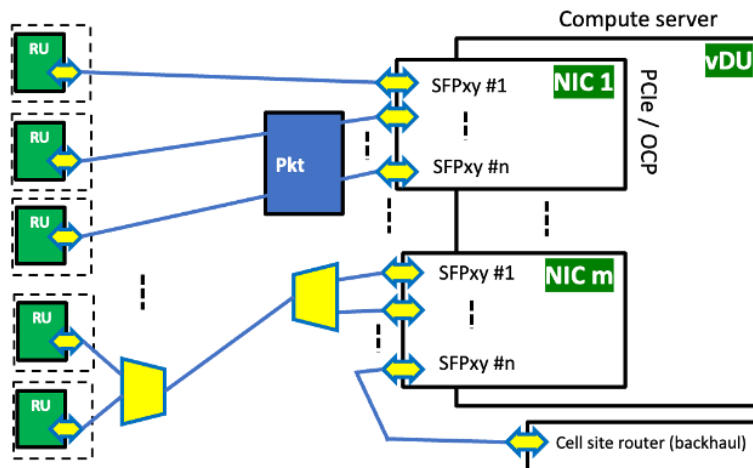

Figure 35: Cloud RAN optical solution. Several connectivity solutions between vDU and RU are show (from top to bottom) parallel dual or bidi gray fibers, packet aggregation and DWDM aggregation.

During June-August 2024, the MOPA Operator Advisory Board were asked about their plans and inputs on Cloud RAN with emphasis on the optical solutions. Their inputs are summarized below:

Timelines: Some operators are already using Cloud RAN while most are currently performing lab evaluations with planned introduction 2026+. Some operators raise concerns that Cloud RAN does not have feature parity with integrated RAN.



Packet and WDM switching: Some operators plan/investigate to use packet switching between RUs and vDU, while others prefer passive WDM. Some operators also plan/investigate optical switching for dynamic path reconfiguration.

Vendor mixing. All operators indicated that they plan to use vendor mixing, either already from the start or in later stages.

MOPA blueprints. The preferred operator Blueprints are indicated in the figure above:

- 7.2.1 (DRAN) and 8.2.1 (CRAN) gray parallel fibers.
- 8.2.3 and 8.2.2. passive DWDM and CWDM CRAN
- 8.2.7 packet switching for CRAN

Data rates and form factors: Operators commonly indicate to use SFP28 ports for LLS connections, while some will also use SFP+ and look to SFP56 for the future. QSFP28 may also be used for aggregation (packet and port) and for future higher data rates.

Requirements for optical pluggables: All operators agree that the same optical requirements needed for integrated RAN (see chapter 6) are also a must for Cloud RAN. Related statements mention that Interoperability is critical to the success and that power consumption and heat are critical.



11. Summary of Optical Pluggables vs. Blueprint

The tables below summarize the pluggable variants used by the different Blueprints described in the paper. It should be noted that the tables in this section include all the pluggables used in the Blueprint illustrations, not only the ones highlighted and covered by the individual Blueprint tables

for example, dual fiber 10G and 25G pluggables used to connect equipment within the same site.

The following codes are used for the 2nd row in the tables below:

- x: a pluggable that is the same at both ends
- y: a pluggable that is only at the network side (closer to mobile core network)
- z: a pluggable that is only at the access side (closer to the RU)

If the module type is the same at both ends, it gets an x in the table. If there are two module types, one for each end, there is both a y and a z in the table entry.

Pluggables vs Blueprints	10G-2 km-O-G-1-2-SFP+	10G-10 km-O-G-1-2-SFP+	10G-15 km-O-G-1-2-SFP+	10G-40 km-C-G-1-2-SFP+	25G-2 km-O-G-1-2-SFP28	25G-10 km-O-G-1-2-SFP28	25G-15 km-O-G-1-2-SFP28	25G-40 km-O-G-1-2-SFP28	50G-2 km-O-G-1-2-SFP56	50G-10 km-O-G-1-2-SFP56	50G-15 km-O-G-1-2-SFP56	100G-2 km-O-G-1-2-QSFP28 *	100G-10km-O-G-1-2-QSFP28 *	100G-15km-O-G-1-2-QSFP28 *	100G-40km-O-G-1-2-QSFP28 *
	x	x	x	x	x	x	x	x	x	x	x	x	x	x	x
7.2.1	o				o				o						
7.2.2		o				o				o					
8.3.1			o				o				o				
8.3.7					o							o			
8.3.8							o							o	
9.2.1	o				o							o			
9.2.2		o				o							o		
9.2.3				o			o								o
9.2.5	o				o							o			
9.2.6		o				o							o		
9.2.7				o			o								o

Table 26: Summary of dual fiber client (only one pluggable pair using each fiber) pluggables needed for each Blueprint. (* The 100G dual fiber pluggables may also be 4x25G, e.g., 100G-40km-O-L-4-2-QSFP28)



Pluggables vs Blueprints	10G-10 km-O-B2-2-1-SFP+	10G-15 km-O-B2-2-1-SFP+	10G-40 km-O-B2-2-1-SFP+	25G-10 km-O-B2-2-1-SFP28	25G-15 km-O-B2-2-1-SFP28	25G-40 km-O-B2-2-1-SFP28	50G-10 km-O-B2-2-1-SFP56	50G-15 km-O-B2-2-1-SFP56	100G-10 km-O-B2-2-1-QSFP28	100G-15 km-O-B2-2-1-QSFP28	100G-40 km-O-B2-2-1-QSFP28
	yz	yz	yz	yz	yz	yz	yz	yz	yz	yz	yz
7.2.2	o			o			o				
8.3.1		o			o			o			
8.3.6											
8.3.7					o					o	
9.2.2	o			o					o		
9.2.3			o			o					o
9.2.4											
9.2.6	o			o					o		
9.2.7			o			o					o

Table 27: Summary of bidi client (only one pluggable pair using each fiber) pluggables needed for each Blueprint. (* The 100G dual fiber pluggables may also be 4x25G, e.g., 100G-40km-O-L-4-2-QSFP28).

Pluggables vs. Blueprints	10G-10 km-*-C-6-2-SFP+	25G-10 km-*-C-6-2-SFP28	10G-15km-O-L-12.2-SFP+	25G-15km-O-L-12.2-SFP28	10G-15 km-C-D-48-2-SFP+	25G-15 km-C-D-48-2-SFP28
	X	X	X	X	X	X
8.3.2	o	o				
8.3.3			o	o		
8.3.4					o	o
8.3.5					o	o
8.3.6					o	o
9.2.4					o	o
9.2.8					o	o

Table 28: Summary of line (multiple pluggable pairs sharing each fiber using WDM) pluggables needed for each Blueprint.



Pluggables vs. Blueprints	25GS-PON-20 km-O-B3-1-SFP28-IONU								
	25GS-PON-20 km-O-B3-1-SFP28-ONU								
	25GS-PON-20 km-O-B3-1-SFP28-OLT								
	XGSPON-20 km-OL-B3-1-SFP+-IONU								
	XGSPON-20 km-OL-B3-1-SFP+-ONU								
	XGSPON-20 km-OL-B3-1-SFP+-OLT								
	GPON-20 km-OS-B3-1-SFP-IONU								
	GPON-20 km-OS-B3-1-SFP-ONU								
	GPON-20 km-OS-B3-1-SFP - OLT								
		y	z	z	y	z	z	y	z
9.2.9	o	o		o	o		o	o	
9.2.10	o		o	o		o	o		o

Table 29: Summary of TDM-PON pluggables needed for each Blueprint.



12. Summary of important technologies, capabilities, and components not yet available

This section discusses technologies and features that are not yet available in current products but are relevant to the evolution of the Blueprints described in the previous sections. The focus is on pluggable devices: other technological trends from which radio equipment could benefit, like co-packaged optics (CPO), are not covered by the current version of this paper.

12.1. Optical transceivers operating at high temperature

Optical transceivers operating at high temperatures are relevant to any equipment that may operate in a harsh environment, like the RUs in the Blueprints described in Sections 7, 8 and 9. Telecom transceivers share most of the characteristics developed for datacom applications, but with some important differences. The capability to operate at temperatures higher than 100 °C is probably the most important one, due to the higher density of integrated circuits in new generation radio equipment. Due to the operation in an uncontrolled environment, and limitations in weight and size, solutions commonly used in data centers, such as active cooling, are more difficult to apply in radio systems. High-temperature pluggable transceivers would allow the radio equipment to become smaller and lighter, with positive effects on the speed and cost of network rollouts.

The first industry to use integrated photonics was that of datacom transceivers, where the high volumes enable important investments in new technologies. Unfortunately, while silicon photonics modulators and photodetectors are tolerant to high temperatures, current commercial lasers for telecom applications are less so. Examples of solutions for lasers in high temperature systems:

- Quantum dot lasers are a promising but not fully mature technology.
- External laser sources, placed away from the thermal hot spots, proposed today primarily for co-packaged optics.
- Improved material and laser structures, e.g 980 nm VCSELs used in the new IEEE 802.3cz Multi-Gigabit Glass Optical Fiber Automotive Ethernet up to 125°C.

12.2. Cost effective high-capacity transceivers

Intensity-Modulated Direct-Detection (IM-DD) systems have been extensively used for mobile networks (as evident from this paper) and are simpler and more cost-effective alternatives to coherent systems. However, IM-DD systems suffer from limited distance and power budget performance at high bit rates due to the fundamental impact of chromatic dispersion and receiver sensitivity (while coherent detection discussed in the next section mitigates these impairments by taking advantage of electrical channel equalization techniques, which offer operation at much lower SNR). For 100 Gb/s, the practical limit today for IM/DD systems is approximately 40 km/20 dB in the O-band for non-WDM use. The success of 25 Gb/s in the access part of backhaul is expected to generate the need for single fiber solutions with 40 km reach and beyond, for example to extend the reach of the Blueprint 9.2.8 (passive DWDM) or with a link attenuation equal or higher than 20 dB, as in Blueprint 9.2.7 (gray/bidi). Extending the operation of NRZ optical interfaces beyond 25 Gb/s



needs high accuracy tunable chromatic dispersion compensators, for example based on fiber gratings or silicon nitride micro-rings integrated in the TOSA/ROSA. Increasing the number of modulation symbols, as in PAM4, or using spectrally efficient line codes, such as optical duobinary or combined amplitude phase-shift, are other solutions but limited receiver sensitivity leads to implementation complexity and cost, which may become comparable to that of optical coherent modules. For how long the continued development of IM-DD optical pluggables for DWDM applications, based on one of the above solutions, remains cost-effective compared to optical coherent pluggables remains an open question. The new MOPA paper “Coherent lite for mobile networks” [MOPAc-lite] explores the coherent option.

12.3. Pluggable optical amplifiers and dispersion compensators

Though tolerated at the CO and hub sites, optical amplifiers are not usually allowed at the RU and cell sites due to their large footprint, power consumption and cost. Compact optical amplifiers implemented in Pluggable Optical Line System (POLs) would be highly beneficial, in these aspects, for DWDM Blueprints where wavelength filters introduce a high insertion loss (e.g., Blueprints 8.3.3, 8.3.4, 9.2.8 and 9.2.4) and could allow the upgrade at 25 Gb/s or higher bitrate of all current 10 Gb/s installation, which is impossible today due to link attenuation constraints.

Similar considerations hold for Dispersion Compensating Modules (DCM) that are today quite bulky, adding to the link loss and latency. Pluggable implementations, possibly tunable to fit all practical network design cases and avoid inventory issues, would enable 25G transceivers to extend beyond 15 km and to continue to use cost effective IM-DD interfaces at bit rates higher than 25 Gb/s. Bismuth doped fiber amplifier can be one of the candidates to resolve the link budget issue in O-band DWDM.

12.4. Cost-effective tunable filters and wavelength switches

One drawback of current DWDM systems is the need to keep the inventory of all variants of transceivers and OADMs working at different wavelengths. This is impractical in mobile transport applications where installation times and cost must be minimal. Reconfigurable OADMs (ROADM) would relieve operators from installing and storing many variants of fixed OADMs, by replacing them with a single reconfigurable device. However, the ROADMs used in optical metro networks are based on high-performance but expensive Wavelength Selective Switches (WSS). Silicon micro-ring resonators could be a promising technology to realize pluggable and low-cost ROADMs. They apply, for example, to Blueprints 8.3.4 and 9.2.4.

Tunable optical filters enable new mobile transport architectures for the same Blueprints, replacing the OADM with a cost-effective power splitter, according to a broadcast-and-select architecture. Current tunable filters based on MEMS, liquid crystals or thin film filters are either too big or only support a limited number of DWDM channels, as in NG-PON2. New silicon photonics designs would offer decreased size and cost.

13. Solutions under evaluation and future work

13.1. LLS using TDM-PON with separate ONU box

The industry has been exploring the possibility of using TDM-PON to provide connectivity between the RU and DU in a CRAN architecture with a Low Layer Split interface. Some of the challenges to accomplish this are bandwidth and latency.

- **Bandwidth.** LLS has higher bandwidth requirements than HLS. The RU interfaces are typically 10 Gb/s or 25 Gb/s rates. LLS variants that generate variable rate traffic can allow aggregation of several RUs on a 25G TDM-PON (and higher), provided the line rate is not fully used by each RU.
- **Latency.** The latency requirement for LLS is much tighter than HLS, on the order of 25-500 μ s one-way [eCPRIreq]. Several efforts have been made to reduce the latency of TDM-PON in order to allow it to be used for certain distances. The methods include reduced burst sizes in the upstream and a real-time control interface (called Cooperative Transport Interface) between the DU scheduler and the OLT scheduler (called Cooperative DBA). These measures are specified in the following standards documents:
 - O-RAN CTI Specification [ORAN-CTI].
 - ITU-T G series supplement on Cooperative DBA [ITU G.Sup.71].

It should be noted that the Cooperative DBA and CTI concepts are still experimental and real-world conditions will be needed to assess their potential.

An illustration for TDM-PON for LLS using an external ONU is shown in Figure 36.

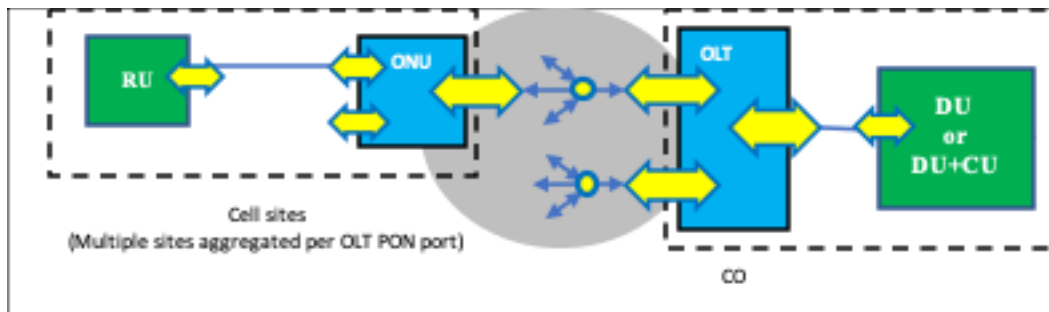

Figure 36: LLS using TDM-PON with a separate ONU box.

13.2. LLS using TDM-PON with pluggable ONU

An illustration for TDM-PON for LLS using a pluggable ONU is shown in Figure 37. The ONU functionalities must be built into the optical module itself.

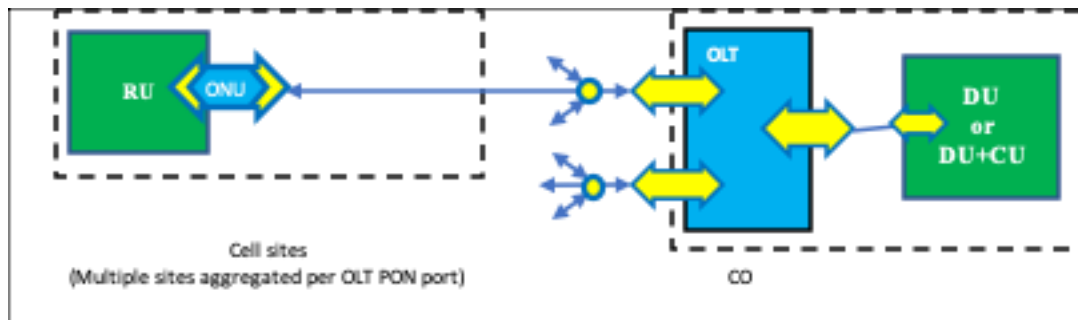

Figure 37: LLS using TDM-PON with a pluggable ONU module.

13.3. Higher speed TDM-PON technologies

The currently defined and available TDM-PON technology above 10G per wavelength is 25GS-PON [25GSPON]. ITU-T has specified Higher Speed PON (HSP) [G.9804.x] for asymmetrical 50/25 Gb/s. The specification for the physical layer of a 50G/50G symmetrical variant of HSP is still in progress in ITU-T [G.9804.3]. The use of these higher speed PONs will be gated by the economic availability of new technology needed to make them possible.

13.4. LLS using semi-active DWDM wavelength multiplexed links over a power splitter ODN (WS-WDM-PON)

An architecture that is being explored by several operators who have an extensive power splitter PON network is an overlay of DWDM wavelengths on the same Power Splitter ODN (PS-ODN) to serve designated RUs that may be located within the area served by the TDM-PON. The dedicated wavelengths can be an effective way of meeting the high bit rate and low latency requirements of LLS while leveraging the existing PON infrastructure. The main difference of this Wavelength Selected WS-WDM-PON architecture from the typical semi-active DWDM wavelength architecture (Wavelength Routed WR-WDM-PON) is that a power splitter is used as the branching node rather than a wavelength Mux.

There are two added challenges for WS-WDM-PON:

- Higher insertion loss: typical PON optical budget classes range from 29 to 35 dB. Techniques that can help address this target include the use of FEC and higher optical power optics.
- Wavelength selection on the receive side: this will require a tunable filter at the RU end in addition to the tunable lasers that are part of the traditional DWDM optics.

On the other hand, it is assumed that fewer wavelengths will be needed per PON for WS-WDM-PON than for WR-WDM-PON since the ODN is expected to be shared as an overlay with other TDM-PONs that have existing PON end-points. In most cases, four wavelengths (and at most eight wavelengths) will be sufficient since most of the PON splitter ports are assumed to be serving other applications. The P2P overlay wavelengths can operate at 10 Gb/s or 25 Gb/s.

An illustration for this WDM architecture with a power splitter ODN is shown in Figure 38. What is not shown is the coexistence, on the same fiber, of other legacy TDM-PONs. There is no interaction

between these, other than the fact they share a common fiber. They operate at independent wavelengths, just like there are many independent radio frequencies operating in the air at the same time, with no interaction between them.

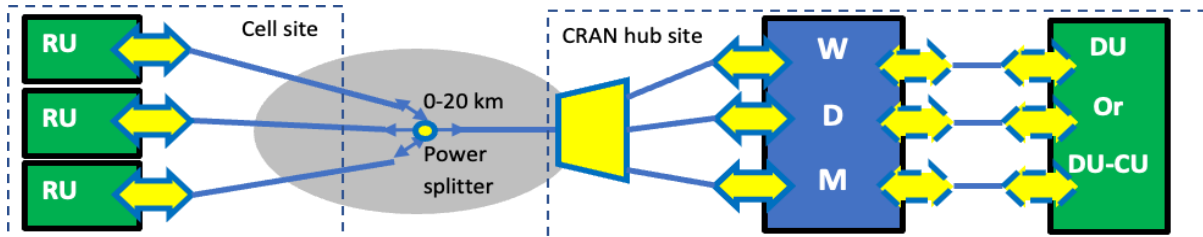

Figure 38: LLS using semi-active DWDM wavelength multiplexed links over a power splitter ODN (WS-WDM-PON).

13.5. 50 Gb/s xWDM 15 km LLS blueprint

50 Gb/s is the next data rate to be employed to address the increasing bandwidth requirement in LLS links. 50 Gb/s gray optics are already available in QSFP28 form factor and are being introduced in SFP56 form factor. Similar to other rates, xWDM is likely needed for use cases such as those illustrated in chapter 8.3.3 (15 km RU-DU, passive DWDM over a single fiber Blueprint), chapter 8.3.4 (15 km RU-DU, passive DWDM bus over a single fiber Blueprint) and chapter 8.3.5 (15 km RU-DU, semi-active DWDM over a single fiber Blueprint).

The target characteristics are as follows:

- Up to 15 km P2P links
- SFP56 form factor
- Industrial temperature range (-40 °C to 85 °C)
- 48 channels.
- Wavelength grid and insertion loss budget are under study.

Annex A “50 Gb/s xWDM 15 km LLS blueprint” provides further details.

13.6. LLS data rate auto-negotiations

Optical auto-negotiation simplifies installation in a heterogeneous environment, where it's not possible to duplicate the same deployment scenario parameters every time. Auto-negotiation also reduces the need for strict cabling regimes as PHY type and technology as well as PHY modes are resolved by negotiation thus minimizing human error.

CPRI 7.0 [cpri7.0] has a mechanism in the standard: a parallel detection scheme defined in clause (4.5.2 /4.5.3) where both peer-ends cycle through their respective rates and FEC combinations. The case of only CPRI 2.4G through 24Gb/s is relatively simple as host ASIC Serdes and optical pluggables can relatively quickly lock to a new data rate (of course given that these rates are supported by the hardware components) as the convergence and recovery of valid data and clock typically occurs at a microsecond level.



There are no major concerns implementing a CPRI stack that complies with this mechanism. The caveat with the current defined scheme and time periods defined in the CPRI 7.0 specification is that there is no guarantee of a resolution on parallel detection if more than four line rates are specified.

With Ethernet-based fronthaul eCPRI [eCPRI] is introduced with lower speeds, starting at 10 and 25 Gb/s. With relatively modest design changes, another line data rate could be included, which would enable continued interop with pure CPRI peer-ends.

With the introduction of 50 Gb/s operation, the space becomes more challenging, due to the evolution of host ASIC Serdes/CDR and optical pluggables with DSPs to cope with 50Gb/s operation. The time to train and converge data and clock-recovery are very challenging to meet the requirement of the CPRI parallel detection mechanism. Thus, extra care is needed in crafting a system budget and selection of suitable components to allow for an interoperable CPRI parallel detection mechanism.

With an increased focus on Ethernet based eCPRI fronthaul and the introduction of 100 Gb/s Ethernet, a mechanism to complement the CPRI parallel detect mechanism is needed. This should reliably allow for a broader mechanism of Auto Negotiation across 2.5G CPRI though 100Gb/s eCPRI in a multi-capable pluggable port while reducing the need for special consideration of Host ASIC serdes/CDR and optical pluggables.

Looking at IEEE, 802.3 [802.3] clauses 28 and 73 define auto-negotiation over twisted pair where ~15 different modes can be negotiated. The method uses pulses similar to the link integrity test (LIT) pulses defined for 10BASE-T. Each device declares its possible modes of operation (baud rate, duplex mode, FEC mode, possibly encoding, etc.)

The IEEE 802.3dj is targeting optical 200Gb/s while optical fiber is not covered (Exceptions are a few optical 1GE modes, where half/full duplex can be negotiated). Moreover, optical modes might use different wavelengths dependent on the mode. No common channel available to perform negotiation is defined.

Of course, optical data rate auto-negotiation only applies to multi-rate optical modules, such as SFP56 supporting 10/25/50GBASE-LR (incl supporting NRZ for 10/25G and PAM-4 for 50G).

MOPA will investigate defining a startup procedure for eCPRI providing similar capabilities to CPRI. Combining the startup procedures of CPRI and eCPRI might be an additional option.

13.7. 30-40 km LLS WDM solutions

MOPA Operator Advisory Board members, and others, have identified the need for 30+ km WDM solutions in mobile LLS. Currently, the longest WDM blueprints specified are 15 km (see chapters 8, 9). While commercial 10 Gb/s 40 km systems are available in the market (40 channels, 100 GHz, C-band), achieving 30-40 km with 25 Gb/s IM/DD WDM systems is technically challenging.



Using Tables 4 and 5 the resulting required loss budgets are as follows:

- 40 km: O-band 20 dB, C-band 15 dB
- 30 km (extrapolating between 20 and 40 km table values, assuming. 2 dB margin, 6x connectors): O-band 17 dB, C-band 12.5 dB
- Mux/Demux pair loss: DWDM 48 ch 11 dB, CWDM 6 ch 4.5 dB. LWDM (sect. 12.5): 4.5 dB for matched pairs (two variants) or 3.5 dB each side for one variant.

As examples, the resulting total loss for 40 km DWDM in C-band would be 26 dB and 30 km LWDM in O-band would be 21.5 dB for matched pairs or 24 dB for one variant.

Due to the higher loss in O-band, 30 km may be the current limit for cost-effective implementations as well as keeping SFP28 pluggables within a 2.5W power dissipation envelope, either DWDM (where the grid should be above the ZDW as outlined in sect 12.5 and Annex A) or 12 channel LWDM. For LWDM, an APD receiver is needed, which may also allow for the higher loss case of one variant MUX/DeMUX [tanake_3ca].

For C-band, chromatic dispersion compensation is required. Electronic Dispersion Compensation (EDC) is the preferred solution, which may allow 40 km DWDM operation. The drawback with EDC is the challenge of keeping the SFP28 module consumption within the target of 2.5 W: 3 W or even a few tenths more may be needed (also considering that I-temp is assumed).

There's an interesting comparison between 25 Gb/s NRZ and 12.5 GBd PAM-4. Initial investigations for both EML and MZM transmitters indicate both are viable options: 12.5 GBd PAM-4 may offer lower power consumption while there's no PHY standard for 12.5 GBd PAM-4 systems.

13.8. 100 Gb/s IM/DD LLS WDM solutions

Extending the discussion in the previous section of IM/DD WDM systems, 100 Gb/s operation will be required as a future data rate in LLS systems.

Clearly, at such high data rates, coherent detection (see the MOPA paper on Coherent lite for mobile networks [MOPAc-lite]) has a clear advantage in overcoming problems with chromatic dispersion and sensitivity. However, using IM/DD when possible is attractive from a footprint (SPFx form factor as required in RUs), power consumption and cost perceptive.

Continuing the example from the previous section, a 15 km 12-channel LWDM system in O-band would require a total loss budget of 16 dB for one variant MUX/DeMUX and 12.5 dB for matched filters. This appears to be achievable using similar technology as in the recent work on 100 Gb/s 40 km BiDi in ITU-T G.9806 Amd 3 and IEEE 802.3dk.

13.9. 100G retimed and linear technology outlook

As introduced in Chapter 6, the next data rate and form factor after 50 Gbps SFP56 is 100 Gbps SFP112.

In order to better understand the 100 Gbps technology and its availability, a survey was sent out to the MOPA members June-August 2024. (Note that the survey does not ask for commercial products or relates to any commercial aspects but rather the availability of technical implementations.) The responses are summarized below.

One of the aspects of the survey was to understand the availability of retimed and linear implementations. The Figure below illustrates the differences between retimed, LPO and LRO implementations, where the latter remove the DSP or CDR in both Tx and Rx parts or just in Rx part, respectively. The benefit of this would be optical pluggables with lower power consumption and cost, with the drawback of more complex signal integrity engineering including with the host system.

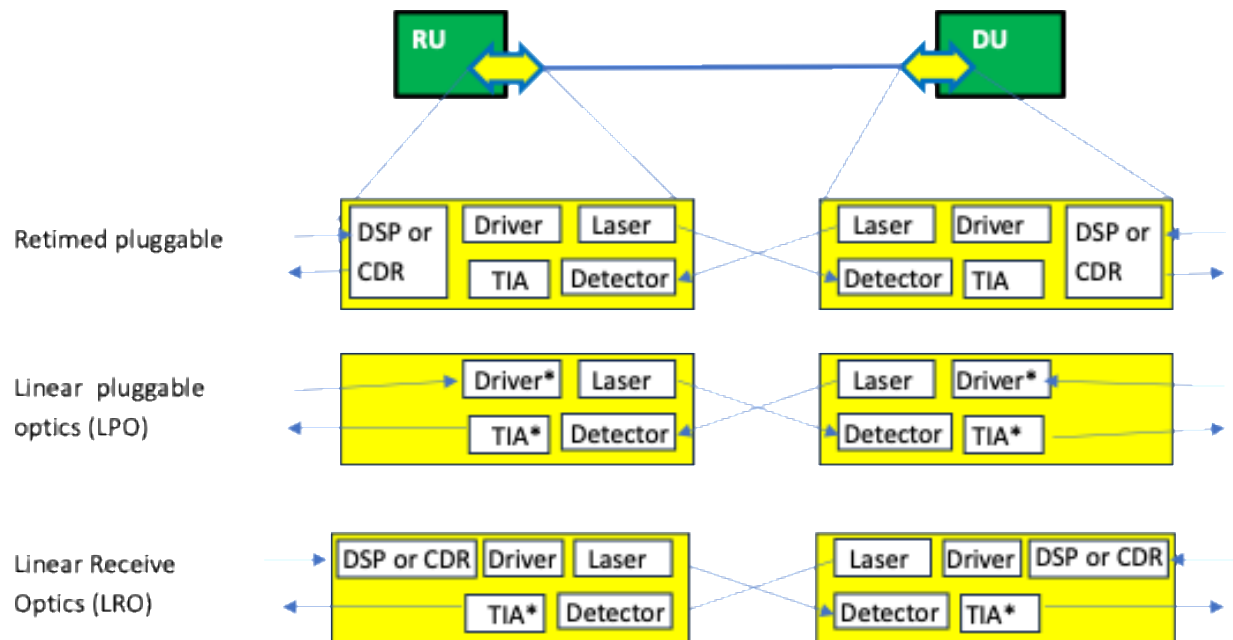

Figure 39: Illustration of retimed, linear (LPO) and linear receive (LRO) optical pluggables in an LLS example with RU and DU. * Indicates that the laser Driver and TIA (transimpedance amplifier) in the linear implementations may be enhanced with channel equalization capabilities.

Availability of retimed SFP112 implementations:

- **EML:** in general, it is indicated that 53 GBaud EMLs suitable for FR/LR/ER/BiDi are currently available on a component level.
- **LR 10 km:** One response indicated availability end of 2024, several indicate availability 2025/26, and one indicates after 2026. EML/PIN is indicated.



- **ER 40 km:** One response indicated availability at the end of 2024, while several indicate availability after 2026. EML/APD or enhanced EML w PIN are indicated.
- **BiDi:** Several indicate availability 2025/26, and one indicates after 2026. EML/PIN is indicated.
- **FR 2 km:** One indicates after 2026. EML/PIN is indicated.

Availability of LPO and LRO SFP112 implementations: There are much fewer responses compared with retimed. Some indicate LPO FR, LR and SR and LRO LR availability end of 2025.

SFP112 signal recovery / integrity features: Several indicate analog CDR but also DSP with equalization is mentioned.

Power consumption:

- **Retimed LR 10 km:** Responses: several stated the ambition to reach the target of 2.5 W, but also 3.5 W and 2.4-3W are indicated.
- **Retimed ER 40 km:** 3.5 W, 2.4-3W and 3-3.5W are indicated.
- **BiDi:** same as dual fiber
- **FR 2 km:** 1.9-2.5W is indicated.
- **LRO:** 1.4-2W is indicated for LR/ER/BiDi.
- **LPO:** 1-1.5W is indicated for FR/LR.

Temperature range: all pluggable options are planned to be available in C-, E- and I-temp.

Multi-rate operation: In general, pluggables implementations will support multi-rate operation, where lower data rates may be supported with CDR bypass.

Enhanced features and management: The responses indicated that SFP112G CDR based pluggables will support BER test, electrical loopback, optical loopback capabilities, while this may not be supported on LPO/LRO modules. It's indicated that SFP112G with CDR based will support tight sync class C, while tight sync support with LPO/LRO is not clear at this point. Regarding Diagnostic features, supported functions mentioned are: Tx/Rx SNR Monitor and Eye Monitor.



14. Conclusion

Optical solutions are essential enablers for the global mobile network rollouts, as they bring capacity and performance needed for 5G and future 6G transport. Driven by the acceleration of 5G deployments and consumer adoption, MOPA proposes a common view and understanding of the optical solutions needed for 5G transport (fronthaul and backhaul). The aim is to solve the current challenges faced by operators, system vendors and optical pluggable suppliers—specifically ambiguity and complexity—and enable them to make the right technology choices and focus on the most relevant needs of the industry. MOPA benefits the entire ecosystem by ensuring timely, cost-efficient, and optimized architectures.



15. References

- [OptConn] S. Dahlfors, et al. "5G Mobile Pluggables - Blueprints for Global Deployments", <https://opticalconnectionsnews.com/webinars/optical-connections-webinar-series-5g/>
- [M2083] ITU-R Rec. M.2083-0 "IMT Vision – Framework and overall objectives of the future development of IMT for 2020 and beyond", Sept 2015
- [G8300] ITU-T Rec. G.8300: "Characteristics of transport networks to support IMT-2020/5G", May 2020
- [Wiki5G] <https://en.wikipedia.org/wiki/5G>
- [LTEbands] https://en.wikipedia.org/wiki/LTE_frequency_bands
- [NRbands] https://en.wikipedia.org/wiki/5G_NR_frequency_bands
- [TS38306] 3GPP TS 38.306 V16.1.0 (2020-07).
- [TS38470] 3GPP TS 38.470 V16.3.0 (2020-09) "Technical Specification Group Radio Access Network; NG-RAN; F1 general aspects and principles (Release 16)"
- [TS38801] 3GPP TR 38.801 V14.0.0 (2017-03): "Study on new radio access technology: Radio access architecture and interfaces (Release 14)"
- [GSTR-TN5G] ITU-T Technical Report GSTR-TN5G: <http://handle.itu.int/11.1002/pub/8124d287-en>
- [OIF-Thermal] OIF: Implementation Agreement for Thermal Interface Specification for Pluggable Optics Modules, IA # OIF-Thermal-01.0, May 18th 2015
- [ETS-EMC] ETS 300 386, ETSI: Public Telecommunications Network Equipment EMC Requirements
- [FCC15] FCC Part 15, Federal Communications Commission (USA) - Part 15 (Radio Frequency Devices)
- [TDM-PON] https://www.itu.int/en/ITU-T/studygroups/2017-2020/15/Documents/OFC2018-2-Q2_v5.pdf , <https://www.itu.int/rec/T-REC-G.Supp66-202009-I/en>
- [G.652] ITU-T Rec. G.652 "Characteristics of a single-mode optical fibre and cable". Nov 2016
- [G.698.2] ITU-T Rec. G.698.2 "Amplified multichannel dense wavelength division multiplexing applications with single channel optical interfaces". Nov 2018
- [G.694.2] ITU-T Rec. G.694.2 "Spectral grids for WDM applications: CWDM wavelength grid", Dec 2003
- [G.9802.x] ITU-T Rec. G.9802, G.9802.1, G.9802.2 (work in progress) "Wavelength division multiplexed passive optical networks (WDM PON)"
- [G.9804.x] ITU-T Rec. G.9804.1, G.9804.2, G.9804.3 (work in progress) "Higher speed passive optical networks (HSP)"
- [G.9807.x] ITU-T Rec. G.9807.1, G.9807.2 "10-Gigabit-capable symmetric passive optical network (XGS-PON)"
- [G.984.x] ITU-T Rec. G.984.1, G.984.2, G.984.3, G.984.4, G.984.5, G.984.6, G.984.7 "Gigabit-capable passive optical networks (GPON)"
- [G.989.x] ITU-T Rec. G.989.1, G.989.2, G.989.3 "40-Gigabit-capable passive optical networks (NG-PON2)
- [eCPRIreq] CPRI. "Transport Network V1.2 (2018-06-25) Requirements Specification Common Public Radio Interface: Requirements for the eCPRI Transport Network"
- [ORAN-CTI] O-RAN Technical Specification WG4.CTI-TCP.0-v01.00 "Cooperative Transport Interface Transport Control Plane Specification", 2020 (v2 2021 pending).
O-RAN Technical Specification WG4.CTI-TMP.0-v01.00 "Cooperative Transport Interface Transport Management Plane Specification", 2020 (v2 2021 pending)
- [G.Supp.71] ITU-T series G Supplement 71 "OLT Capabilities for supporting CO DBA" (publication pending)



[IEC61753]	IEC 61753-021-2, "Fibre optic interconnecting devices and passive components performance standard - Part 021-2: Grade C/3 single-mode fibre optic connectors for category C - Controlled environment", Dec 2007
IEC 61753-022-2	Fibre optic interconnecting devices and passive components - Performance standard - Part 022-2: Fibre optic connectors terminated on multimode fibre for category C - Controlled environment.
[25GSPON]	25G PON MSA group, "25GS-PON Specification: 25 Gigabit Symmetric Passive Optical Network" v2.0, Aug 2021
[10GEAPON]	IEEE 802.3av-2009 "Part 3: Carrier Sense Multiple Access with Collision Detection (CSMA/CD) Access Method and Physical Layer Specifications, Amendment 1: Physical Layer and Management Parameters for 10Gb/s Passive Optical Networks", Clause 75
	IEEE 802.3bk "Amendment 1 to 802.3-2012: Physical Layer Specifications and Management Parameters for Extended Ethernet Passive Optical Networks"
[802.3ca]	IEEE 802.3ca-2020 "Amendment 9: Physical Layer Specifications and Management Parameters for 25 Gb/s and 50 Gb/s Passive Optical Networks", Clause 141
[SmartT]	smarttunable-msa.org
[ER-6G-Spectrum]	https://www.ericsson.com/en/blog/2022/6/6g-spectrum-why-its-fundamental
[Hexa-X]	https://www.ericsson.com/en/blog/2021/1/hexa-x-initiative-to-shape-6g
[RemMon]	"MOPA Remote Performance Monitoring Specification", v1.0, May 21, 2023. See https://mopa-alliance.org/papers-and-presentations/
[M2160]	ITU-R Rec. M.2160-0 "Framework and overall objectives of the future development of IMT for 2030 and beyond", Nov 2023
[MOPA-PerfMon]	Mobile Optical Pluggables Alliance (MOPA), Remote Performance Monitoring Specification, May 21, 2023 https://mopa-alliance.org/papers-and-presentations/
[cpri7.0]	See http://cpri.info/spec.html
[eCPRI]	See http://www.cpri.info/downloads/eCPRI_v_2.0_2019_05_10c.pdf
[802.3]	https://www.ieee802.org/3/
[tanaka_3ca]	https://www.ieee802.org/3/ca/public/meeting_archive/2016/11/tanaka_3ca_1_1116.pdf
[IEEE802.3cz]	IEEE 802.3cz Physical Layer Specifications and Management Parameters for Multi-Gigabit Glass Optical Fiber Automotive Ethernet
[MOPAsync]	MOPA Technical paper "Optical pluggable performance for tight synchronization", Version 1.0, March 25, 2024, https://mopa-alliance.org/papers-and-presentations/
[MOPAc-lite]	MOPA Technical paper "Coherent lite for mobile networks", Version 1.0, March 25, 2024, https://mopa-alliance.org/papers-and-presentations/
[CloudRAN]	See eg https://www.ericsson.com/en/ran/cloud , https://www.nokia.com/networks/mobile-networks/airscale-radio-access/cloud-ran/
[server]	https://en.wikipedia.org/wiki/Server_(computing)
[NIC]	https://en.wikipedia.org/wiki/Network_interface_controller
[ethtool]	https://en.wikipedia.org/wiki/Ethtool
[NC-SI]	https://www.dmtf.org/dsp/DSP0222



Appendix A: Referenced Physical Layer Standards Exceptions for MOPA Blueprints



Existing standards and implementation agreements produced by Standards Development Organizations (SDOs), Industry Fora and multi-source agreements (MSAs), where the Blueprints cover the different technical aspects, can help form a broad description of optical solutions useful and important for mobile transport networks. MOPA is working actively to contribute to SDOs such as ITU-T and IEEE to provide requirements and perspective from mobile optics and in general to align the industry. Related to such requirements are form factors for next generation speed upgrades: In Chapters 7 and 8 and the blueprints dealing with direct parallel fiber LLS links, 100 Gb/s is not yet included for p2p links and for blueprints dealing with packet multiplexing, so far only QSFP28 form factor has been listed. However, due to tight requirements on footprint and power consumption (due to stringent thermal requirements) the serial SFP format is favored for radio units. Thus, SFP112 form factor has been added to the LLS p2p blueprints in the next paper revisions.

The tables in this Appendix show the various MOPA Blueprints described in Chapters 7, 8 and 9 along with an industry specification(s) that is closely aligned *or nearly aligned (with exceptions)*. The table rows below "Parameters" list parameters where there are significant differences and where the MOPA Blueprint requirements are not fulfilled. In the case where there are such parameter exceptions, the intent is that they are relatively minor and will allow optics suppliers to leverage existing high-volume transceiver solutions. These tables are informative guidelines.

2 km, 10/25/50G, dual-fiber	10 Gb/s		25 Gb/s		50 Gb/s	
	10G-2km-O-G-1-2-SFP+		25G-2km-O-G-1-2-SFP28		50G-2km-O-G-1-2-SFP56	
	IEEE 802.3 Cl. 52 (10GBASE-L)*	MOPA Blueprint	IEEE 802.3 Cl. 114 (25GBASE-LR)*	MOPA Blueprint	IEEE802.3 Cl. 139 (50GBASE-LR)*	MOPA Blueprint
Parameter		No exceptions		No exceptions		No exceptions

Table APA.1: 2 km, dual-fiber, Blueprints. Insertion loss (IL) budget = 2.8 dB in O-band. *The insertion loss budgets for these IEEE specifications (IL = 6.3 dB, for up to 10 km) may be viewed as overengineered and not be cost optimized for the corresponding MOPA Blueprint.

2 km, 100G, dual-fiber	100 Gb/s (Dual-Fiber)	
	100G-2km-O-G-1-2-QSFP28 or 100G-2km-O-C/L-4-2-QSFP28	
	IEEE 802.3 Cl. 140 (100GBASE-FR1) or 100G CWDM4 MSA	MOPA Blueprint
Parameter		No exceptions

Table APA.2: 2 km, 100 Gb/s, dual-fiber IL budget = 2.8 dB in O-band.



10 km, 10/25/50G, dual-fiber	10 Gb/s		25 Gb/s		50 Gb/s	
	10G-10 km-O-G-1-2-SFP+		25G-10km-O-G-1-2-SFP28		50G-10km-O-G-1-2-SFP56	
	IEEE 802.3 Cl. 52 (10GBASE-LR)	MOPA Blueprint	IEEE 802.3 Cl. 114 (25GBASE-LR)	MOPA Blueprint	IEEE802.3 Cl. 139 (50GBASE-LR)	MOPA Blueprint
Parameter						
Wavelength	1260–1355 nm	1260–1355 nm	1295–1325 nm	1295–1325 nm	1304.5 - 1317.5 nm	1304.5– 1317.5 nm
Launch power (min) in OMA minus TDP	-6.2 dBm	-5.4 dBm	-5.0 dBm	-4.3 dBm	-2.9 dBm	-2.2 dBm
Optical Modulation Amplitude (min)	-5.2 dBm	-4.4 dBm	-4.0 dBm	-3.3 dBm	-1.5 dBm	-0.8 dBm

Table APA.3: 10 km, dual-fiber, Blueprint. IL budget = 7 dB in O-band. Since the MOPA IL budget is higher than the one used by IEEE, the MOPA blueprint would use the IEEE specification with a slightly increased launch power and optical modulation amplitude. Also, the wavelength range is tightened compared to the full O-band.

10 km, 10/25/50G, BiDi	10 Gb/s		25 Gb/s		50 Gb/s	
	10G-10km-O-B2-2-1-SFP+		25G-10km-O-B2-2-1-SFP28		50G-10km-O-B2-2-1-SFP56	
	IEEE 802.3 Cl. 158 (10GBASE-BR10)	MOPA Blueprint	IEEE 802.3 Cl. 159 (25GBASE-BR10)	MOPA Blueprint	IEEE 802.3 Cl. 160 (50GBASE-BR10)	MOPA Blueprint
Parameter						
Wavelength	1270/1330 nm (±10 nm)	1270/1330 nm (±10 nm)	1270/1330 nm (±10 nm)	1270/1330 nm (±10 nm)	1270/1330 nm (±10 nm)	1270/1330 nm (±10 nm)
Launch power (min) in OMA minus TDP	-6.2 dBm	-5.4 dBm	-5.0 dBm	-4.3 dBm	-2.9 dBm	-2.2 dBm
Optical Modulation Amplitude (min)	-5.2 dBm	-4.4 dBm	-4.0 dBm	-3.3 dBm	-1.5 dBm	-0.8 dBm

Table APA.4: 10 km, BiDi, Blueprint. IL budget = 7 dB in O-band. Since the MOPA IL budget is higher than the one used by IEEE, the MOPA blueprint would use the IEEE specification with a slightly increased launch power and optical modulation amplitude.



10 km, 10/25/50G, BiDi	10 Gb/s		25 Gb/s		50 Gb/s	
	10G-10km-O-B2-2-1-SFP+		25G-10km-O-B2-2-1-SFP28		50G-10km-O-B2-2-1-SFP56	
	ITU-T G.9806 Amend. 2* (Tables 7-1, 7-2)	MOPA Blueprint	ITU-T G.9806 Amend. 2* (Tables 7-1, 7-2)	MOPA Blueprint	ITU-T G.9806 Amend. 2* (Tables 7-1, 7-2)	MOPA Blueprint
Parameter						
Wavelength	1270/1330nm (±10nm)	1270/1330nm (±10nm)	1289/1314nm (±8nm)	Recommend IEEE wavelength range	1289/1314nm (±8nm)	Recommend IEEE wavelength range
		No other exceptions		No other exceptions		No other exceptions

Table APA.5: Alternative referenced standards for 10 km, BiDi, Blueprint. IL budget = 7 dB in O-band. *The link budgets for these ITU specifications (S class, IL = 15 dB) may be viewed as overengineered and not be cost optimized for the corresponding MOPA Blueprint.

10 km, 100G, Dual-fiber, BiDi	100 Gb/s (Dual-Fiber)		100 Gb/s (BiDi)	
	100G-10km-O-C/L-4-2-QSFP28 or 100G-10km-O-G-1-2-QSFP28		100G-10km-O-B2-2-1- QSFP28	
	IEEE 802.3 Clause 88 (100GBASE-LR4) or Clause 140 (100GBASE-LR1)	MOPA Blueprint	IEEE 802.3dk* or ITU-T G.9806 (Amend. 3)*	MOPA Blueprint
Parameter				
Wavelength	1294.53 to 1310.19 nm (LAN WDM) or 1304.5 to 1317.5 nm	1294.53 to 1310.19 nm (LAN WDM) or 1304.5 to 1317.5 nm	-	TBD
Launch power (min) in OMA minus TDECQ	-2.3 dBm or -1.5 dBm	-1.6 dBm or -0.8 dBm	-	TBD
Optical Modulation Amplitude (min)	-1.3 dBm or -0.1 dBm	-0.6 dBm or +0.6 dBm	-	TBD

Table APA.6: 10 km, 100 Gb/s, dual-fiber and BiDi Blueprints. IL budget = 7.0 dB in O-band. For dual-fiber: Since the MOPA IL budget is higher than the one used by IEEE, the MOPA blueprint would use the IEEE specification with a slightly increased launch power and optical modulation amplitude *In progress.



15 km, 10/25/50G, Dual-fiber	10 Gb/s		25 Gb/s		50 Gb/s	
	10G-15km-O-G-1-2-SFP+		25G-15km-O-G-1-2-SFP28		50G-15km-O-G-1-2-SFP56	
	IEEE 802.3 Cl. 158 (10GBASE- BR20)*	MOPA Blueprint	IEEE 802.3 Cl. 159 (25GBASE- BR20)*	MOPA Blueprint	IEEE 802.3 Cl. 160 (50GBASE- BR20)*	MOPA Blueprint
Parameter						
Wavelength	1270/1330nm (±10nm)	1260 – 1340nm	1289/1314nm (±8nm)	1281- 1322nm	1289/1314nm (±8nm)	1281- 1322nm

Table APA.7: 15 km, dual-fiber, Blueprint. IL budget = 9 dB in O-band. *The BR20 specification (IL budget = 15 dB) is used as a starting point, but the higher loss budget may be viewed as overengineered and therefore not cost-optimized when applied to this MOPA blueprint. However, here the system would not use the diplexer.

15 km, 10/25/50G BiDi	10 Gb/s		25 Gb/s		50 Gb/s	
	10G-15km-O-B2-2-1-SFP+		25G-15km-O-B2-2-1-SFP28		50G-15km-O-B2-2-1-SFP56	
	IEEE 802.3 Cl. 158 (10GBASE-BR20)*	MOPA Blueprint	IEEE 802.3 Cl. 159 (25GBASE- BR20)*	MOPA Blueprint	IEEE 802.3 Cl. 160 (50GBASE-BR20)*	MOPA Blueprint
Parameter						
Wavelength		No exceptions	1289/1314nm (±8nm)	1289/1314nm (±8nm)	1289/1314nm (±8nm)	1289/1314nm (±8nm)

Table APA.8: 15 km, BiDi, Blueprint. IL budget = 9 dB in O-band. *The BR20 link budget = 15 dB may be viewed as overengineered and not be cost optimized for the corresponding MOPA Blueprint.

15 km, 100G Dual-fiber, BiDi	100 Gb/s (Dual-Fiber)		100 Gb/s (BiDi)	
	100G-15km-O-C/L-4-2-QSFP28 or 100G-15km-O-G-1-2-QSFP28		100G-15km-O-B2-2-1-QSFP28	
	100G 4WDM-20 [†] or 100G Lambda MSA (100G-LR1-20) ^{††}	MOPA Blueprint	IEEE 802.3dk* or ITU-T G.9806 (Amend. 3)*	MOPA Blueprint
Parameter				
		No exceptions		TBD

Table APA.9: 15 km, 100 Gb/s, dual-fiber and BiDi Blueprints. IL budget = 9 dB in O-band. [†]The link budget for this specification (IL = 10.2 dB) may not be cost optimized for the corresponding MOPA Blueprint. ^{††}The link budget for this specification (IL = 9.8 dB) may not be cost optimized for the corresponding MOPA Blueprint. *In progress.



15 km, 10/25G CWDM	10 Gb/s		25 Gb/s	
	10G-10km-*-C-6-2-SFP+			
Parameter	ITU-T G.695 (07/2018)	MOPA Blueprint	ITU-T G.698.5, Application codes D12-8- 10B-9-D1 (10 km, IL = 10.7 dB) and D12-8-20B-9-D1 (20 km, IL = 15.9 dB) †	MOPA Blueprint
		Use Table 8-15 as starting point for a 6- wavelength interface		Use these ITU-T application codes as starting points.

Table APA.10: 10 km, CWDM Blueprint. IL loss budget = 11.5 dB. †In progress

15 km, 10/25G DWDM	10 Gb/s		25 Gb/s	
	10G-15km-C-D-48-2-SFP+		25G-15km-C-D-48-2-SFP28	
Parameter	ITU-T G.698.1 (11/2009) Table 8-3	MOPA Blueprint	ITU-T G.698.1 (06/2023) Table 8-6	MOPA Blueprint
		No exceptions*		No exceptions**

Table APA.11: 15 km, DWDM Blueprint. IL budget = 17.8 dB in C-band. *ITU-T specification supports 1000 ps/nm of chromatic dispersion which is more than the 270 ps/nm assumed for 15 km of standard G.652 SMF. **The referenced ITU-T specification applies to a chromatic dispersion tolerance of 200ps/nm which corresponds to 10km of standard G.652 SMF.



40 km, 10/25/100G Dual-fiber	10 Gb/s		25 Gb/s		100 Gb/s	
	10G-40 km-C-G-1-2-SFP+		25G-40 km-O-G-1-2-SFP28		100G-40 km-O-L-4-2-QSFP28 or 100G-40 km-O-G-1-2-QSFP28	
	IEEE 802.3 Cl 52 (10GBASE-ER)	MOPA Blueprint	IEEE 802.3 Cl 114 (25GBASE-ER)	MOPA Blueprint	IEEE 802.3 Cl. 88 (100GBASE-ER4) Or 100G Lambda MSA (100G-ER1-40)	MOPA Blueprint
Parameter						
Wavelength	1530 to 1565 nm	-	1295 to 1310 nm	-	1294.53 to 1310.19 nm or 1308.09-1310.19 nm	-
Launch power (min) in OMA minus TDP	-2.1 dBm	+1.0 dBm*	-1.0 dBm	+1.0 dBm*	+0.1 dBm or +3.3 dBm	+2.1 dBm* Or +5.3 dBm*
Optical Modulation Amplitude (min)	-1.7 dBm	+1.4 dBm*	0.0 dBm	+2.0 dBm*	NA or +4.7 dBm	NA or +6.7 dBm*

Table APA.12: 40 km, dual-fiber, Blueprint. IL budget = 20 dB in O-band or 15 dB in C-band. Since the MOPA IL budget is higher than the one used by IEEE, the MOPA blueprint would use the IEEE specification with an increased launch power and optical modulation amplitude. *Such high optical modulation amplitude may not be achievable with available cost-effective technology.

40 km, 10/25/100G BiDi	10 Gb/s		25 Gb/s		100 Gb/s	
	10G-40 km-O-B2-2-1-SFP+		25G-40 km-O-B2-2-1-SFP28		100G-40 km-O-B2-2-1-QSFP28	
	IEEE 802.3 Cl. 158 (10GBASE-BR40)	MOPA Blueprint	IEEE 802.3 Cl. 159 (25GBASE-BR40)	MOPA Blueprint	IEEE 802.3dk [†] or ITU-T G.9806 (Amend. 3 [†])	MOPA Blueprint
Parameter						
Wavelength		No exceptions	1314/1289nm	1314/1289nm		TBD
Launch power (min) in OMA minus TDP	-1.0 dBm	+1.0 dBm*	-1.0 dBm	+1.0dBm*		TBD
Optical Modulation Amplitude (min)	0.0 dBm	+2.0 dBm*	0.0 dBm	+2.0 dBm*		TBD

Table APA.13: 40 km, BiDi, Blueprint. Insertion loss budget = 20dB in O-band. Since the MOPA IL budget is higher than the one used by IEEE, the MOPA blueprint would use the IEEE specification with an increased launch power and optical modulation amplitude. *Such high optical modulation amplitude may not be achievable with available cost-effective technology. †In progress.



TDM-PON	2.5/1.25 Gb/s		10/10 Gb/s		25 / 10 Gb/s or 25 Gb/s	
	GPON-20 km-OS-B3-1-SFP-OLT GPON-20 km-OS-B3-1-SFP-ONU		XGS-PON-20 km-OL-B3-1-SFP+-OLT XGS-PON-20 km-OL-B3-1-SFP+-ONU		25GS-PON-20 km-O-B3-1-SFP28-OLT 25GS-PON-20 km-O-B3-1-SFP28-ONU	
Parameter	ITU-T G.984.2	MOPA Blueprint	IEEE 802.3 Clause 75 (10GBASE-PR-D/U3) or ITU-T G.9807.1(Amend 2) (Annex B)	MOPA Blueprint	IEEE 802.3 Clause 141 (25/10-PQ30X) (25/25-PQ30X) or 25GS-PON MSA V2.0	MOPA Blueprint
IL Budget	28dB	No exceptions	33 dB or up to 35 dB	No exceptions	29 dB or 31 dB	No exceptions

Table APA.14: 20 km TDM-PON Blueprint. Multiple insertion loss classes from 28 dB to 35dB depending on configuration and data-rate.



Annex A: 50 Gb/s xWDM 15 km LLS blueprint



1. Implementations under study

Different implementations for 50 Gb/s WDM are currently under study while keeping in mind the network requirements described in this paper:

- Maximum distance of 15 km to accommodate the same requirement used for lower data rates and current infrastructure.
- SFP56 is the preferred form factor as it is beneficial to keep the same mechanical dimensions as lower data-rate transceivers.
- As described in chapter 6.1 “I-temp” operating temperature range and low power consumption are very important.

Since technologies are already available in the market and employed in gray optics, 25 GBaud PAM4 modulation format appears to be the most reasonable choice.

The increasing data rate makes it very challenging to meet the required performance. To fulfill these needs, different options are under evaluation to meet the insertion loss budget requirement and reduce chromatic dispersion impairments.

To have acceptable dispersion penalties, O-band could be adopted. It is generally known that O-band has a risk of FWM (Four Wave Mixing), especially when the wavelengths are close to the zero-dispersion wavelength of the fiber (1310 nm typ.¹²) and the grids are denser, but theoretically FWM can be managed by operating far enough from the zero-dispersion wavelength. Another consideration is that longer wavelengths distant from the zero-dispersion, such as 1370 nm, has a disadvantage in dispersion. Optimum wavelength grids, such as 1320 nm to 1350 nm, are under study.

In C-band, the dispersion penalty is a big challenge for 15 km distances at high data rates. One way to overcome this challenge is to implement dispersion compensation methods like DCM (dispersion compensation modules – e.g. based on dispersion compensation fiber or fiber Bragg gratings). EDC (electronic dispersion compensation) at the receiver, signal predistortion at the transmitter, ODC (optical dispersion compensation) at transmitter or receiver by means of photonic integrated circuits (PICs) or the use of modulation formats resilient to chromatic dispersion (duobinary and its extension: Combined Amplitude and Phase Shift Keying (CAPS), Differential Quadrature Shift Keying (DQPSK)). All these techniques have their pros and cons, as discussed in [4] and [5], and further evaluation is needed to understand the most suitable one.

On the other hand, a coherent-transmission based solution in C-band is sufficient to overcome the dispersion challenge with no risk of FWM. As is commonly known, this solution also enables higher data rates such as 100 Gb/s, which will likely be a necessary data rate in LLS links in the future. In this case, however, since the DSP is indispensable for the implementation, power consumption of the 100G Coherent pluggable module is expected to be around 6W in a QSFP28 form factor over I-

¹² Rec. ITU-T G.652 (11/2016) states in Tables 1 and 2 that the zero-dispersion wavelength is between 1300-1324 nm.



temp range at present (see section 6.1, Table 2). This is a major challenge to be addressed in order to adopt such an approach for radio units. It is also challenging to incorporate all the necessary components into an SFP56 form factor. Also due to the DSP, latency is another potential challenge which needs to be carefully evaluated especially for use in LLS link. (see Appendix B “*Optical pluggable performance for tight synchronization*”). To accommodate the needs of mobile applications, “Coherent Lite” is under consideration as described in Chapter 11.2.1.

2. Candidate O-band wavelength grid vs Four-wave mixing penalties

In order to assess the possible penalties arising from Four Wave Mixing (FWM) for O-band WDM, a simplified analytical model derived from [1], [2] and [3] has been used for simulations. FWM penalties are known to get worse with lower amounts of chromatic dispersion, close spacing of wavelengths, and high optical power levels per wavelength launched into the fiber [2,3]. To estimate the order of magnitude of such penalties, we have used three scenarios, which are listed and illustrated below:

- 1) A “baseline” scenario, considering 12 wavelengths with 800 GHz spacing on the LAN-WDM grid.
- 2) An “overlay” upgrade scenario, in which 3x100GHz DWDM wavelengths are injected into each of the 12 LAN-WDM filter slots of the “baseline” scenario.
- 3) An “expansion” upgrade scenario, in which the original 12 x 800 GHz LAN-WDM wavelengths of the “baseline” scenario are not touched but 48 new wavelengths, with 100 GHz spacing on the DWDM grid are added right above of the LAN-WDM region (>1322 nm).

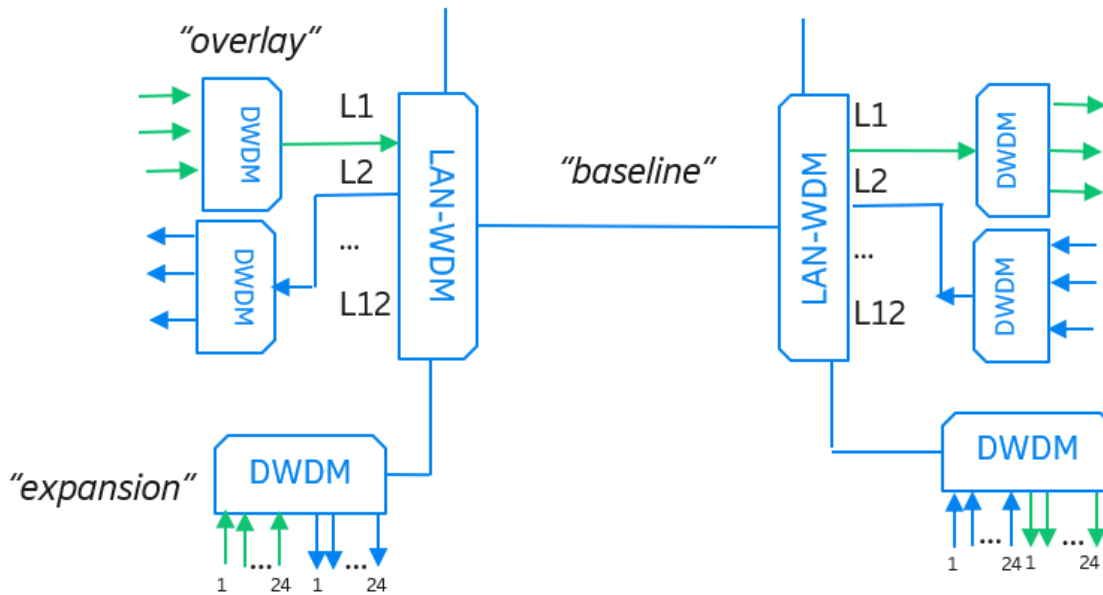

Figure ANA.1: "baseline", "overlay" and "expansion" scenarios.

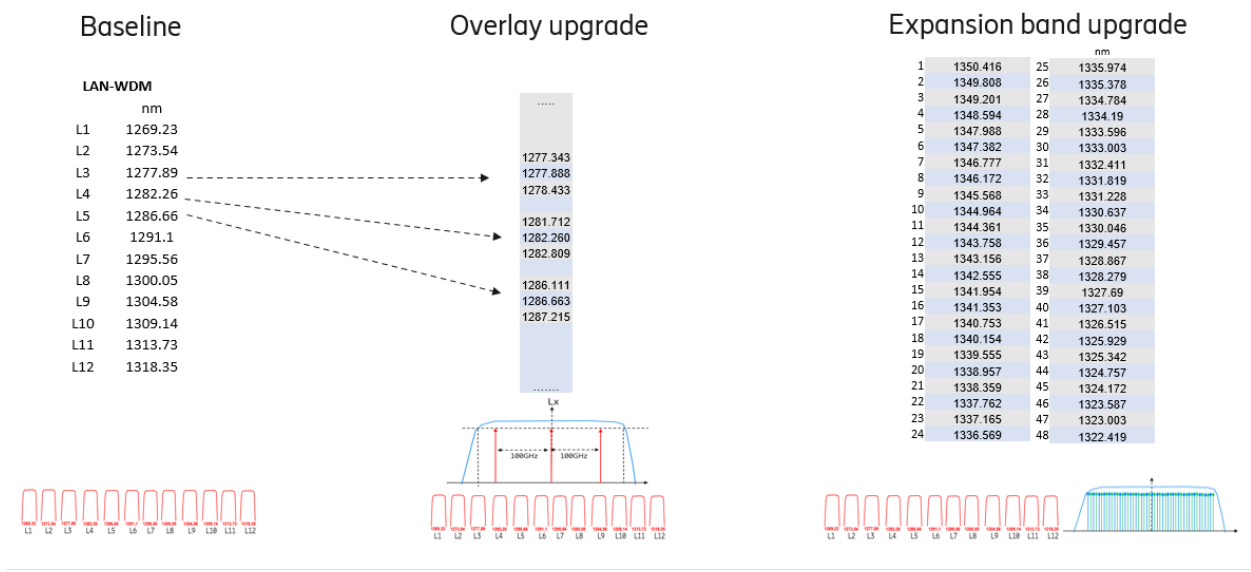

Figure ANA.2: "baseline", "overlay" and "expansion" wavelength grids.

The simulation calculates the OSXR (optical signal to nonlinear crosstalk ratio) in a worst-case condition, assuming corner conditions with all FWM penalties coinciding:

- maximum transceiver output power and minimum optical filter losses,
 - These conditions result in a +2 dBm launch power per channel after WDM filters,
- nominal fiber distance of 15 km (for maximum cumulative effect),

- polarization alignment of all transmitted wavelengths,
- fixed spacing wavelength grids,
- channels operate on exactly the nominal wavelength.

A sweep of the optical fiber “zero dispersion” wavelength, in the allowed variation range dictated by ITU-T G.652 [G.652], is performed in order to exacerbate all possible ‘resonance’ conditions between the signal wavelength grid and the specific zero-dispersion wavelength value. Once OSXR is obtained, it can then be translated into BER under the simplifying assumption that crosstalk noise behaves as additive Gaussian noise. Then, assuming a target BER of $5E-5$ (Reed-Solomon “KR” pre-FEC threshold), the FWM penalty in dB can be estimated. These simulations are shown in the figures below:

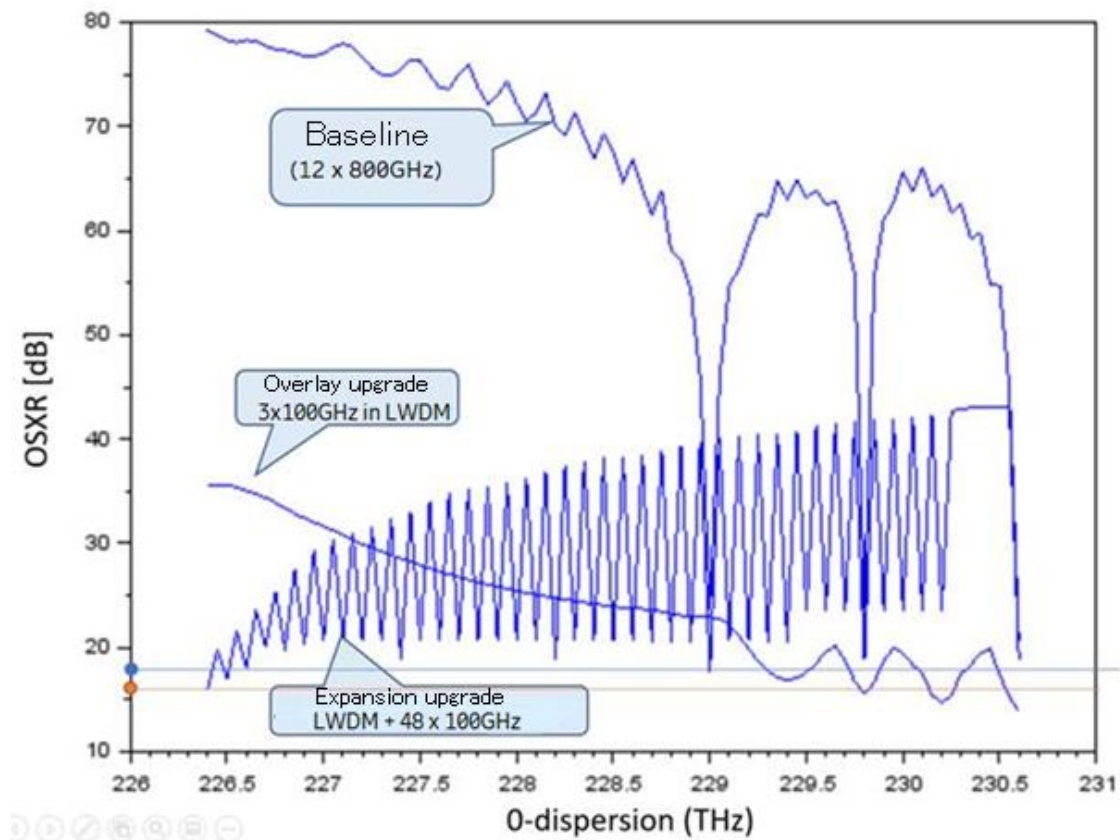

Figure ANA.3: OSXR results obtained by sweeping the zero-dispersion wavelength all over the allowed range, for the three considered scenarios.

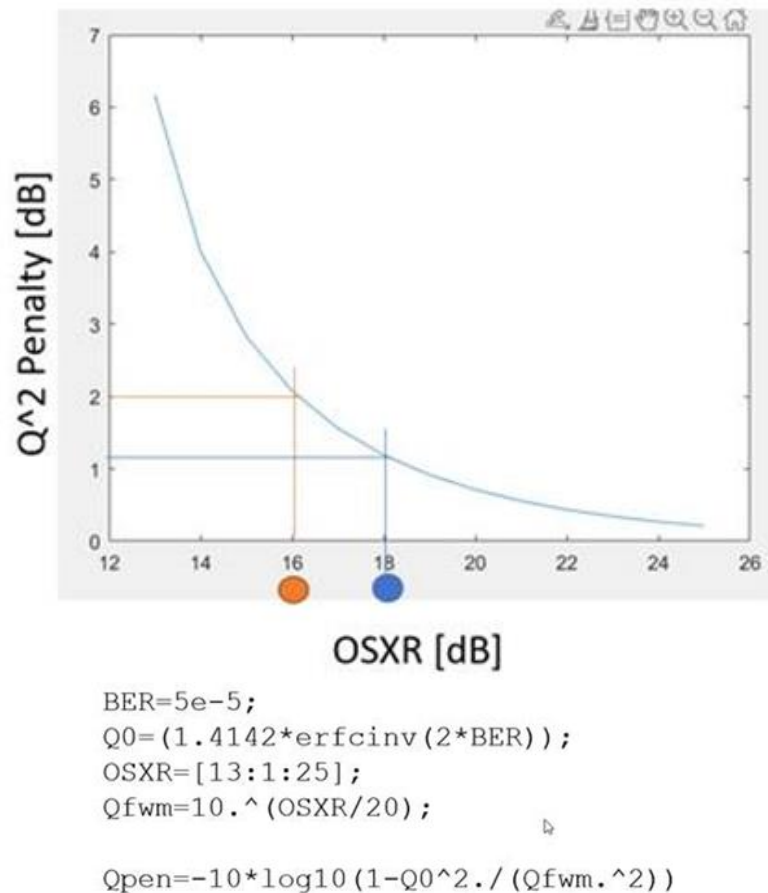

Figure ANA.4: OSXR to penalty conversion under the assumption of additive Gaussian crosstalk noise.

As is shown in the figures above, the “baseline” 12 x 800 GHz LAN-WDM system exhibits three “notches” corresponding to different values of fiber zero-dispersion fiber wavelengths “resonating” with the fixed grid. In this instance, the OSXR is around 18 dB, corresponding to a 1dB penalty. For the system in the “overlay” scenario, the combination of a denser wavelength spacing (100 GHz) together with the operating wavelengths in the vicinity of the fiber zero-dispersion wavelength, the OSXR is less than 16 dB worst case.

For the system in the “expansion” scenario, the effect of a denser wavelength spacing is compensated by the fact the signal wavelengths are relatively far from than the fiber zero-dispersion wavelength. As a result, the worst case OSXR is around 18 dB.

These simulations suggest a conservative worst-case OSNR from FWM effects in the “baseline” and “expansion” scenarios OSNR is around 18 dB, which corresponds to a penalty of about 1dB @ BER=5E-5. It should be noted that these simulations assume extremely unrealistic conditions, as it is very unlikely that all the possible worst-case conditions will occur simultaneously. It should also be noted that this worst-case penalty of 1dB could be further reduced by placing a limit on the



maximum fiber launch power from the transmitter. Each dB of optical launch power reduction results in a 2dB improvement in the OSXR.

Summary: A LAN-WDM grid with its relatively wide spacing, does not suffer from significant FWM penalties. On the other hand, 100 GHz DWDM grids in the 1310 nm range would be more severely impacted by FWM; 100 GHz grids at wavelengths above 1322 nm do not appear to suffer from significant FWM penalties due to the higher levels of chromatic dispersion.

3. Preliminary Blueprint

Whichever solution is ultimately selected, per-channel flexibility and tolerance to various amounts of chromatic dispersion will be required for mobile applications. Moreover, as already mentioned, implementation of these WDM interfaces must fit in widely adopted pluggable format like SFP56 and reuse mature technologies like PAM4 modulation. To minimize the overall link insertion loss, one must carefully consider the number of wavelength channels and filter requirements.

The following table shows estimated loss budgets for C-band and O-band with maximum link distances of 15 km:

	Fiber Attenuation	Connectors Insertion Loss	Maintenance Margin	Mux/DeMux Insertion Loss	Total Loss budget
C-band DWDM 48ch	3.8 dB *	2 dB *	1 dB *	9 dB (2 x 4.5 dB)	15.8 dB
O-band DWDM 48ch	6.0 dB *	2 dB *	1 dB *	9 dB (2 x 4.5 dB)	18.0 dB

*Table ANA.1: Preliminary Loss budget estimations for C-band DWDM and O-band DWDM. * Using the values of Table 4 in Section 6.9.*

DSP-based pluggable modules are increasingly attractive for mobile applications although this function may introduce higher latency, costs and power consumption.

Analog CDR-based solutions can be beneficial in terms of power consumption and latency, however, the ability of these solutions to compensate for various link impairments remains an active area of investigation.

The table below summarizes a preliminary 15 km xWDM 50 Gb/s LLS blueprint:



Typical use cases	15 km RU-DU, passive DWDM over a single fiber Blueprint (chapter 8.3.3) 15 km RU-DU, passive DWDM bus over a single fiber Blueprint (chapter 8.3.4) 15 km RU-DU, semi-active DWDM bus over a single fiber Blueprint (chapter 8.3.5)
Distance	Typ Min 0 km; Typ. Max: 15 km
Channel Insertion Loss	18 dB in O-band, 15.8 dB in C-band (under study)
Chromatic Dispersion	< 65 ps/nm @ 1350nm * (< 270 ps/nm @ C-band**)
Mode, Nr ch., Wavelengths	Dual fiber pluggables, single fiber trunk: 48 wavelengths @ 100 GHz spacing
Temp. Range/Class	I-temp
Lifespan	15 years
Data rates	50 Gb/s
Form factor	SFP56
FEC, Mod format	yes, PAM4 (likely)
Power Class	Under study (PC4 / 2.5 W preferred, but 3.0W appears to be more reasonable target for tunable solutions)
Pluggables codes	50G-15Km-?-?-48-2-SFP56
Key technologies	Low-cost 50Gb/s EML DWDM without wavelength lockers, APD. Athermal AWG or TFF filters
Standards	No

Table ANA.2: Preliminary 15 km xWDM 50 Gb/s LLS blueprint. () 1350 nm is an example of the longest possible wavelength to be adopted with an aim to limit FWM effects. The chromatic dispersion for 1350 nm is calculated using " $S_{omax}/4*L*(\lambda-\lambda_{omin}^4/\lambda^3)$ ", where S_{omax} is the maximum zero dispersion slope (0.092 ps/nm²/km), L is the maximum fiber length (15 km), λ_{omin} is the minimum zero dispersion wavelength (1300 nm), λ is 1350nm. "4 ps/(nm*km)" described in Section 6.9 is not used here because 1350 nm is relatively far from the typical O-band wavelength. (**) This dispersion must be compensated using a DCM in the fiber link or an EDC function in the pluggable module, etc., which requires further evaluation.*

4. References

[1] "FWM simulations in O-band", Dora van Veen & Vincent Houtsma, Nokia Bell Labs – contribution to the P802.3ca IEEE Task Force:

https://www.ieee802.org/3/ca/public/meeting_archive/2016/07/van_veen_3ca_1_0716.pdf

[2] N. Shibata, R. P. Braun, and R. G. Waarts, "Phase-mismatch dependence of efficiency of wave generation through four-wave mixing in a single mode optical fiber," IEEE J. Quantum Electron., vol. 7, pp. 1205-1210, July 1987.

[3] K. Inoue, "Four-wave mixing in an optical fiber in the zero-dispersion wavelength region," J. Lightwave Technol., vol. 10, pp. 1553-1561, Nov. 1992.



[4] E. Forestieri, M. Secondini, L. Poti and F. Cavaliere, "High-Speed Optical Communications Systems for Future WDM Centralized Radio Access Networks," in *Journal of Lightwave Technology*, vol. 40, no. 2, pp. 368-378, 15 Jan.15, 2022, doi: 10.1109/JLT.2021.3131399.

[5] P. Iovanna et al., "Optical Components for Transport Network Enabling The Path to 6G," in *Journal of Lightwave Technology*, vol. 40, no. 2, pp. 527-537, 15 Jan.15, 2022, doi: 10.1109/JLT.2021.3117122.



Annex B: Remote optical module management

1. Description of the application

This annex proposes and describes a messaging channel, a frame structure, a memory map, and a protocol that together enable the management of optical modules at the two ends of an optical link, either WDM or gray and single or dual fiber. The mechanism reuses the head-to-tail message channel (HTMC) defined in ITU-T rec. G.698.4 with focus on remote performance monitoring (RPM).

In the tunable DWDM case, the requirement for end-to-end operation of the messaging channel is that the two module transmitters are tuned to the correct wavelength(s) so that messages sent by one module's transmitter will be received at the receiver port of the other module.

As shown in Figure ANB.1, optical transceivers at both ends of the optical link are equipped to send and receive messages to and from the other end. The messages are transmitted over a low frequency, low modulation depth amplitude modulated channel on top of high-speed digital data (see Figure ANB.1).

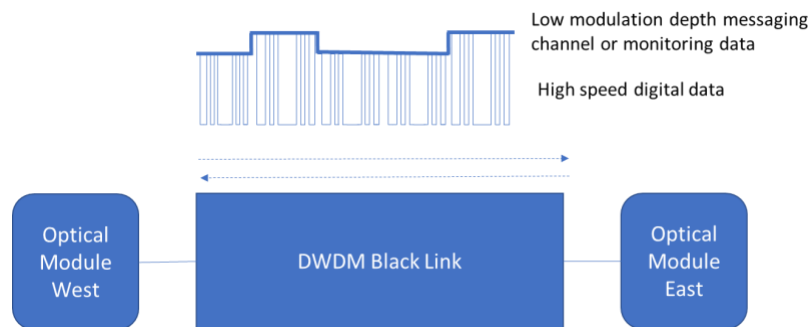

Figure ANB.1: Optical modules exchanging inventory and diagnostics data over a DWDM black link¹³ (as an example).

Unless otherwise specified, the messaging channel is assumed to be generated by the optical module and not by the host system. Similarly, the specified protocols ("state machines") are assumed to run in the module and not in the host system. This makes it desirable to specify the same behavior for the transceivers at both ends of the link.

There are situations where HEE (head-end equipment) (e.g., a DU) may send control messages to transceivers at the TEE (tail-end equipment) (e.g., a RU) or may request data from the TEE transceiver's memory. This scenario is illustrated in Figure ANB.2.

¹³ The term "black link" means that the internal details of the link are not defined here.

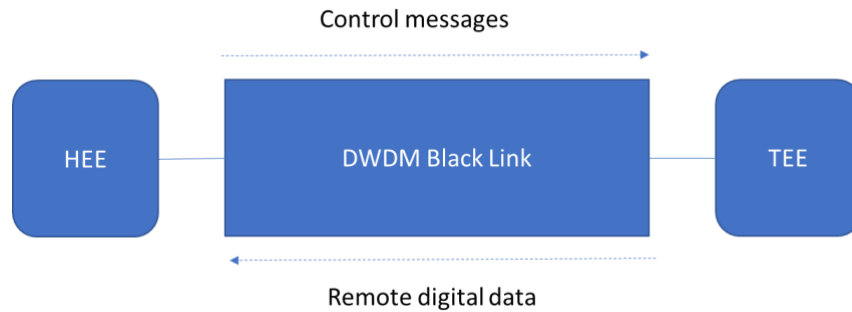

Figure ANB.2: HEE and TEE exchanging control data over DWDM black link example with HEE and TEE

2. Message channel characteristics

The message channel is a low-frequency, low modulation-index channel on top of the regular high speed data signal. It is based on the message channel defined in ITU-T G.698.4. By keeping the modulation index low, below 10%, the receiver sensitivity penalty due to the message channel can be kept to less than 1 dB. The exact signaling rate and tolerance are currently under study. Issues include the potential impact on EDFAs (erbium-doped fiber amplifier) if used in the network, and overall message throughput being adequate.

Parameter	Range	Unit
Signaling rate (-40 to 85°C)	5 kb/s +/- 5%	kb/s
Signaling rate tolerance	100,000	Ppm
Modulation index	0 to 10	%
Modulation format	2-level Manchester code	

Table ANB.1: Message channel characteristics

3. Frame structure and message types

Messages are organized into 48-bit frames as specified by ITU-T Recommendation G.698.4 but new types of messages were defined to enable the end-to-end messaging mechanism:

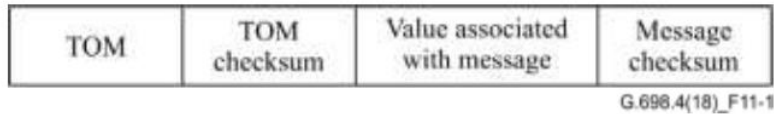

Figure ANB.3: ITU-T Rec. G.698.4 message frame format.

TOM value (11-bit field)	Message type	Message content (24-bit)
0x000 to 0x00B	Used by G.698.4 for frequency tuning	
0x2A0	Command and Response	Send command and respond message
0x2A1	Retransmission	Requesting message retries
0x2A2-0x2A7	Reserved	Reserved
0x2A8	Sending page data content	Send A0h and vendor page data
0x2A9	Sending page data content	Send A2h and reserved page data
0x2AA	Extended Idle	A 24-bit running counter.
0x2AB-0x2AF	Reserved	Reserved

Table ANB.2: New Message types (TOM) used for Remote Performance Monitoring

4. SFP memory pages and registers

To support the messaging channel and RPM, several new registers are added to the existing SFF-8472 / SFF-8690 [SFF8690] standard locations. These registers are added to A2h pages 02h (support registers) and A2h pages 20h to 24h (mapped remote pages). For management purposes, the host software can communicate messages to the remote device through these registers.

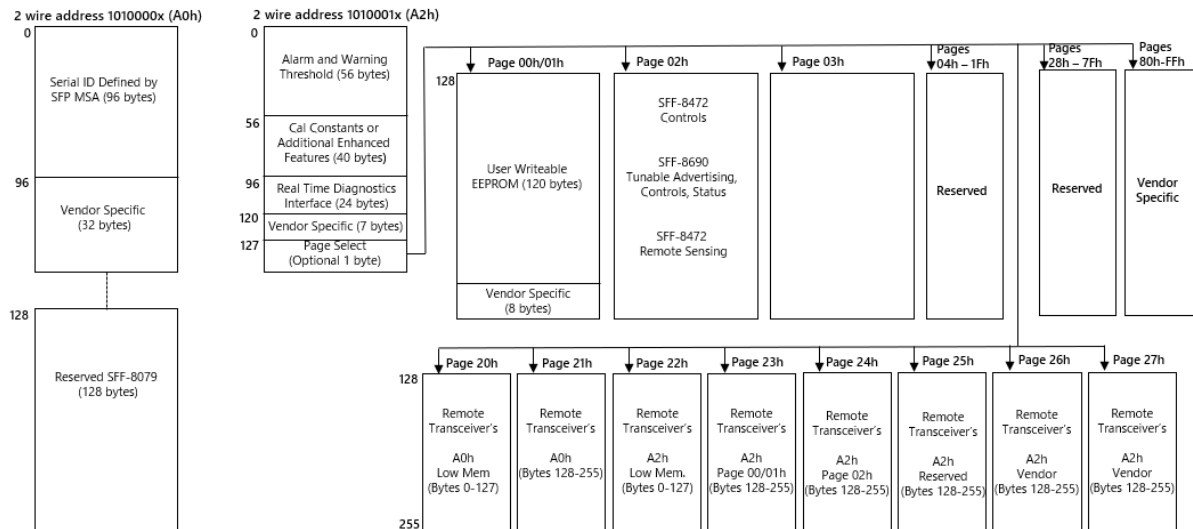

Figure ANB.4: SFF-8472 Memory Organization showing register locations for Remote transceiver.

Data received from the remote device is stored in 5 new pages at A2h pages 20h to 24h, with another 3 pages, 25h to 27h proposed for future and vendor specific use. The mapping between the remote device pages and these locations are given in Table ANB.3. Proposed new registers and their locations are listed in Table ANB.4.

A2h upper page (from the sending device)	Remote page (from the receiving device)
20h	A0h, lower
21h	A0h, upper
22h	A2h, lower
23h	A2h, upper 00/01h
24h	A2h, upper 02h
25h to 27h (optional)	Vendor specific

Table ANB.3: Mapping from remote device pages to new pages at the local (host) device.



A2h Address Bytes	Function	Description
192-197	Status/Debug	Clock Status and Debug
198-207	Error Counters	Return frame error counters, enables calculation of BER or FER
208-210	Tx Remote Cmd	Allow remote memory map to be written.
211	Tx Mod Index	Modulation Index
212-215	Reserved	Reserved
216-231	Reserved	Reserved for Alarm Bit Mask of frames.
232-255	Reserved	Reserved

Table ANB.4. Page 02h Register Summary for Remote Performance Monitoring. Note: The mapping of registers 198-207 in A2 high allows the HEE to monitor the RPM Rx channel error rates. The HEE can request this error rate information and can adjust the Tx modulation index to reduce the error rate.

5. Operations enabled by the message channel

5.1 The value and standardization of remote monitoring and management of optical modules

As described above, adding a message channel and the necessary firmware to SFP transceivers enables the management and monitoring of remote transceivers. For 5G front-haul line systems this means that the host software at the HEE can send commands and request data from individual transceivers at the TEE / RRU site. The technique is generic and can be applied to modules attached to any type of optical link.

Since the transceivers at the TEE may be from different vendors, installed at different times, potentially by different organizations, multi-vendor interoperability is important. Standards development organizations (SDOs) such as the ITU-T SG15 have a role to play in doing the work to publish recommendations for the industry. Typically, those recommendations are readily published once the industry has agreed on a set of specifications through isolated activities such as vendor specific specifications, alliances such as MOPA, and various MSAs such as the Smart Tunable MSA.

5.2 Proposed Remote-Performance Monitoring (RPM) method

There is a common state machine inside the modules at both ends of the link. Under optional host system control, one end of the link is activated as the HEE and will be the module that requests remote DDMI data from the TEE module. The detailed state diagram is currently in development in the industry and is planned to be standardized in a relevant standards group.



5.3 Autonomous module tuning

The Smart Tunable MSA has published a specification for self-tuning of transceivers when they are first plugged into the network, or when a module reset is performed. Self-tuning is fully autonomous because channel isolation components (Mux/Demux) restrict messages received to just those sent on a particular frequency. Like the remote-DDMI methods described here, multiple vendor's tunable modules comply with the self-tuning specification through firmware methods.

5.4 Proposed remote tuning method

In cases where the modules used do not have autonomous tuning capabilities, it is possible to use the messaging channel for remote tuning. If the remote modules comply with SFF-8690 [SFF8690] they will initialize to a default transmit frequency stored in A2h bytes 146-147. However, unless the Tx of the remote device is connected to the correct Mux port, it will not be able to join the network until it is reprogrammed to the correct frequency. This is achieved by having host software and SFP firmware that implements the state diagram discussed above.

6. References

[ITU-T G.698.4]	ITU-T Rec. [G.698.4 "Multichannel bi-directional DWDM applications with port agnostic single-channel optical interfaces", June 2018
[SFF8690]	SFF-8690 "Tunable SFP+ Memory Map for ITU Frequencies", January 2013
[Smart Tunable MSA]	Self-Tuning Optics Interoperability Specification v2.0