



# **MOPA**

## **Introduction and Overview**

**Dec 18, 2023**

# MOPA at-a-glance

---

- **What?**
  - MOPA is an industry effort publishing technical papers describing all relevant high-level **requirements** and optical solution **“Blueprints” for 5G & 6G mobile optical transport networks.**
  - Contribute to standards organizations such as ITU-T, IEEE, SNIA SFF etc.
- **Why?**
  - Increase the industry shared & common view of the relevant **optical solutions for mobile networks.**
  - Easier and with less risk to plan the evolution of mobile optical networks to develop products, and to build networks with improved R&D efficiency.
- **Who?**
  - RAN vendors (**Ericsson, Nokia**), optical pluggable vendors (**Coherent, Lumentum, Sumitomo Electric**) and optical IC vendors (**Semtech**)
  - Mobile operator advisory board: Orange, NTT, Verizon, T-Mobile, Telefonica, Telia, BT, SKT and DT.
- **When?**
  - Started end of 2020 (without legal structure)
  - Publishing papers twice per year: March (OFC), September (ECOC)
  - Incorporated June 2023 as a no-profit, non-stock corporation in Delaware, USA
- **For more info, visit our website <https://mopa-alliance.org>**

# Market background – Growth of 5G

33% YoY mobile traffic growth  
1.6bn 5G subscribers in 2023

Figure 6: Global mobile network data traffic and year-on-year growth (EB per month)

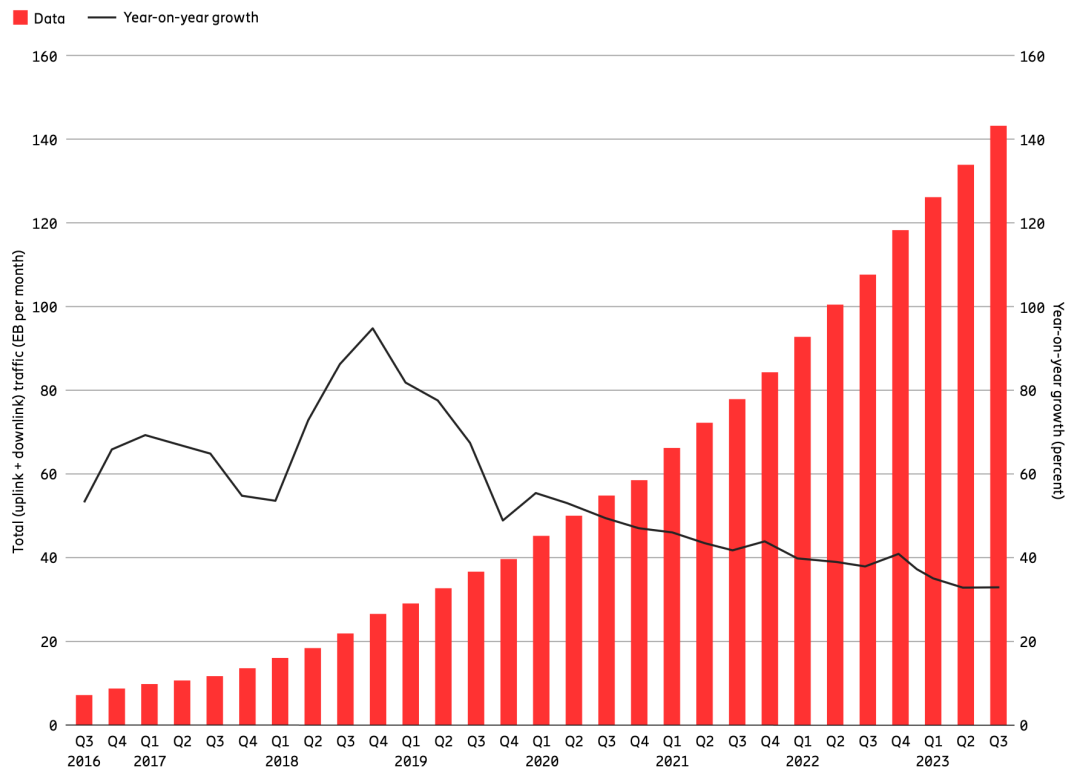

Source: Ericsson traffic measurements (Q3 2023).  
Note: Mobile network data traffic also includes traffic generated by Fixed Wireless Access services.

In India, Nepal and Bhutan, average data traffic per smartphone is the highest globally. It is projected to grow from 31 GB per month in 2023 to around 75 GB per month in 2029 – a CAGR of 16 percent.

Figure 10: Mobile data traffic per smartphone (GB per month)

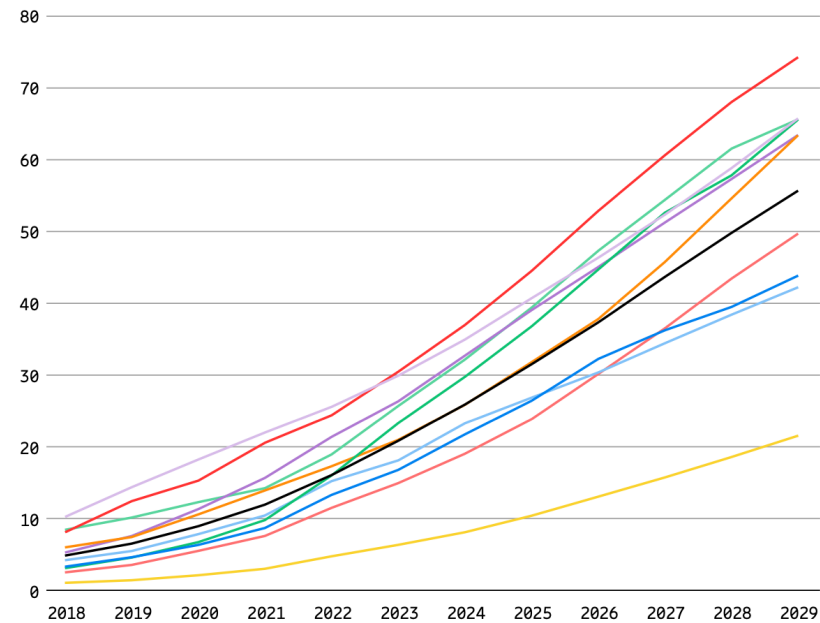

# Market background – Growth of 4G and 5G traffic

Figure 23: Relative traffic growth for peak period by location type in Western Europe

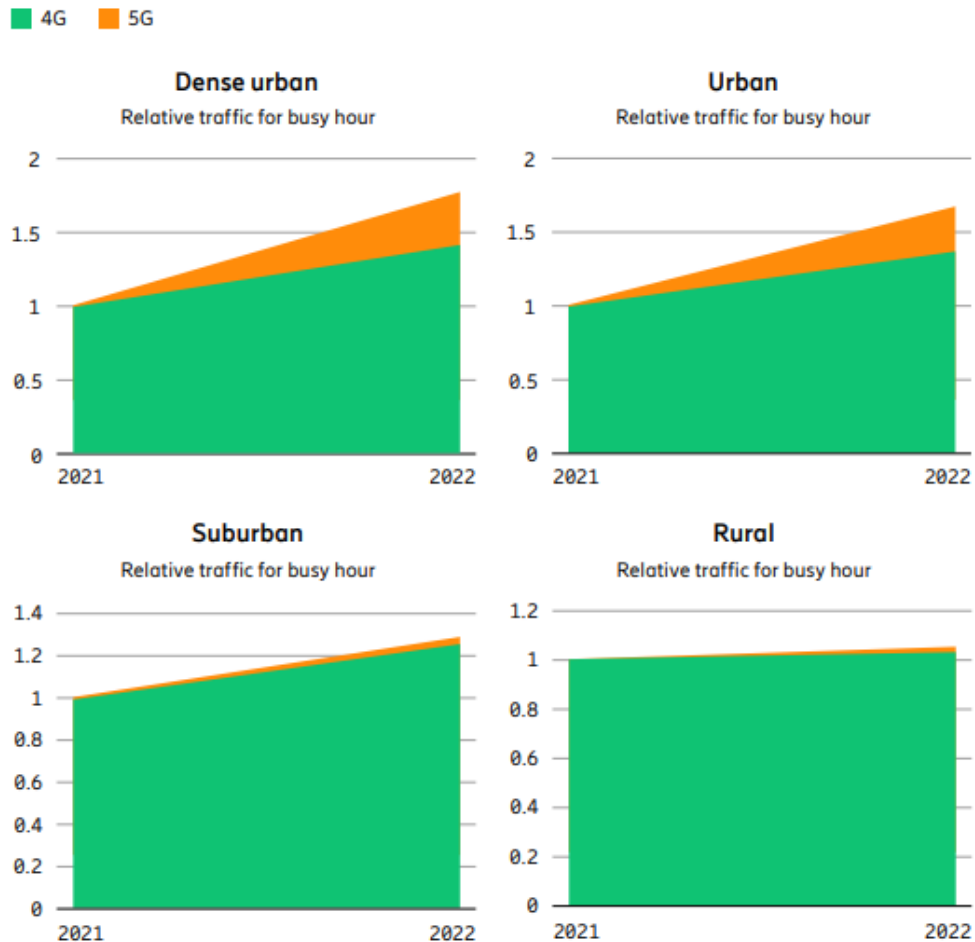

Continued strong growth in mobile subscriber data traffic.

Drives deployment of mobile optics to support overall traffic growth.

# Market background - Advanced use cases accelerate growth

Mobile networks evolve to handle the traffic and performance requirements of new real-time services:

Example: Augmented reality requirements: stringent delay, bounded latency, limited packet loss, etc

This evolution requires more coverage and more capacity => Drives deployment of mobile optics

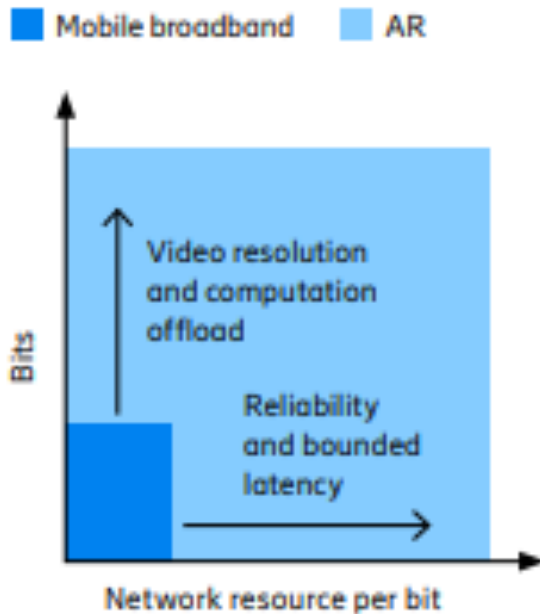
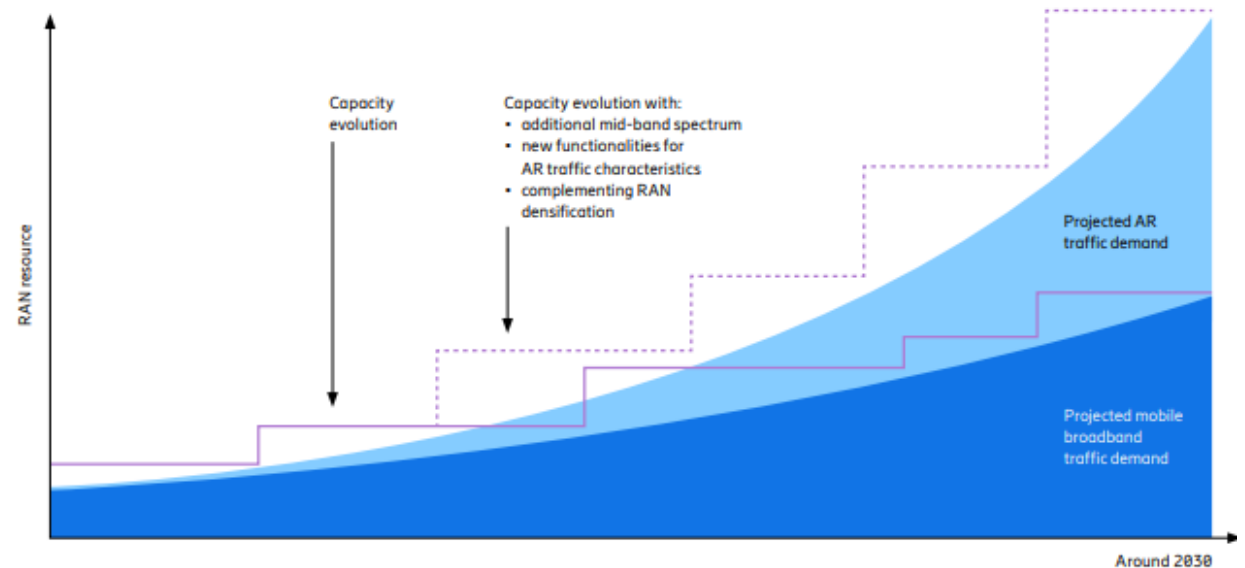
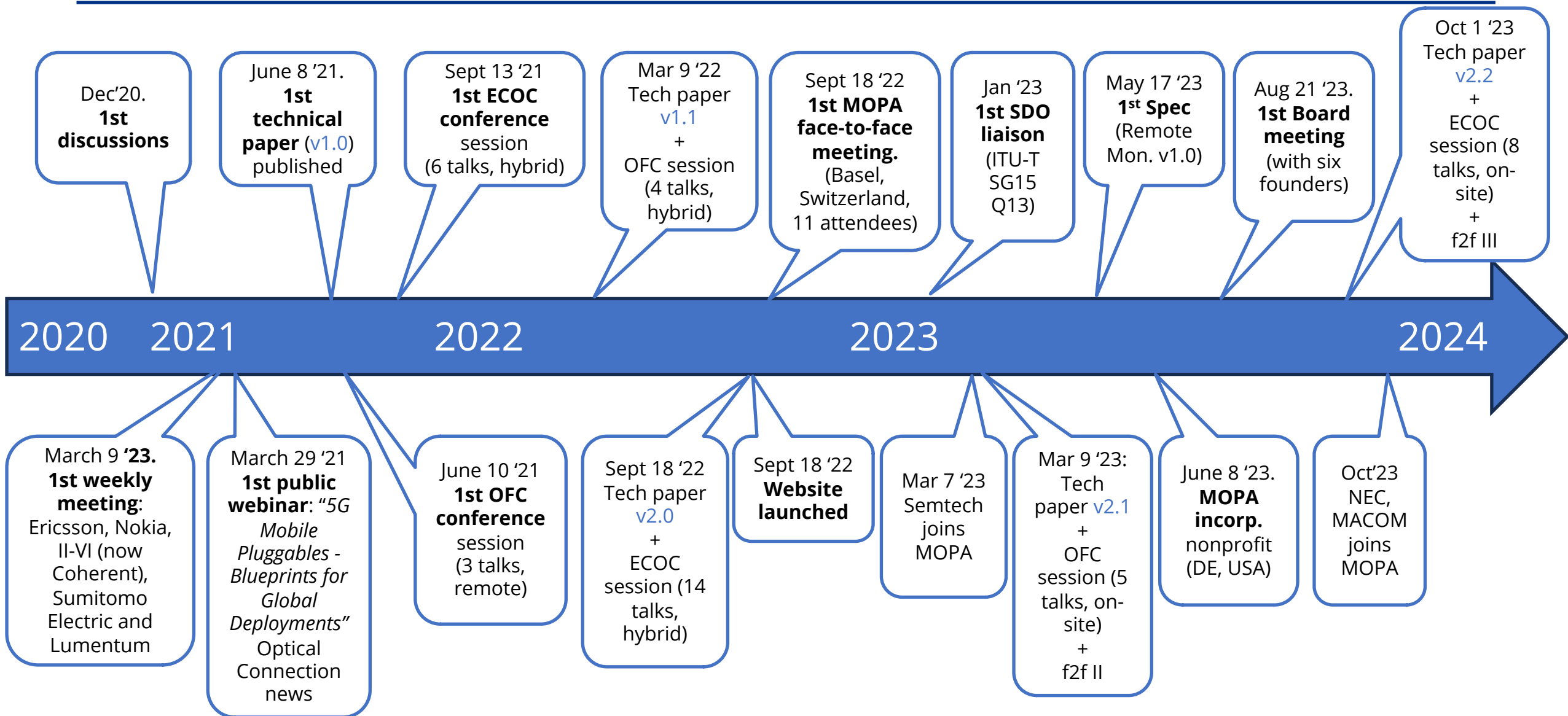

Figure 30: AR and mobile broadband traffic and capacity evolution



# MOPA History



# MOPA Organization (December 2023)

## Board of Directors, Officers:

Chairman, President: Stefan Dahlfors, Ericsson  
Treasurer: Tero Kemilä, Nokia  
Ken Cockerham, Coherent Inc  
Justin Abbott, Lumentum  
Kenneth Jackson, Sumitomo Electric  
Raza Khan, Semtech

## MOPA Members :

Founders: Ericsson, Nokia, Coherent, Lumentum,, Sumitomo Electric, Semtech  
Principal: NEC, MACOM

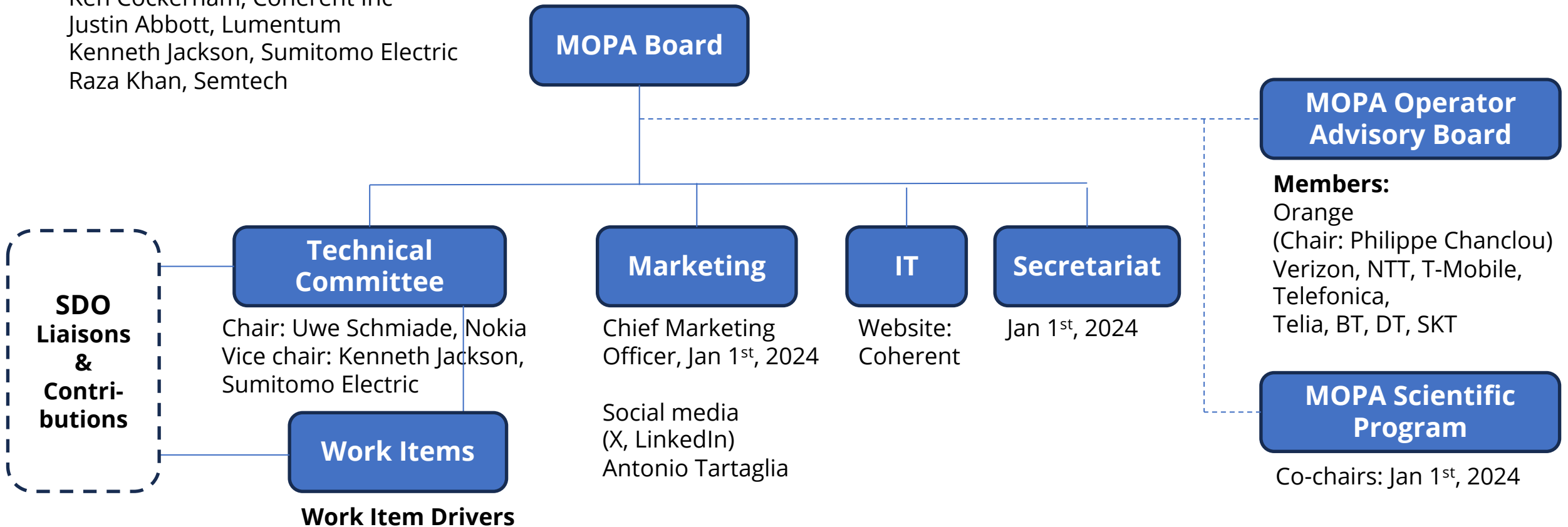

# Mobile Optics Background I

- IMT-2020 (ITU-R M.2083 ) outlines the 5G capabilities
  - Enhanced Mobile Broadband (eMBB)
  - Ultra-Reliable and Low-Latency Communications (URLLC)
  - Very scalable Massive Machine Type Communications (mMTC)
- IMT-2030 enhances and extends the capabilities towards 6G
  - Work in ITU, 3GPP and EU projects
  - See illustration to the right
- 5G is a system (5GS) with:
  - A Radio Access Network part (RAN): **NR** (RU, DU, CU)
  - A mobile core part: **5GC** (UPF, AMF, SMF...)
  - **Transport networks** to connect the RAN and Core nodes

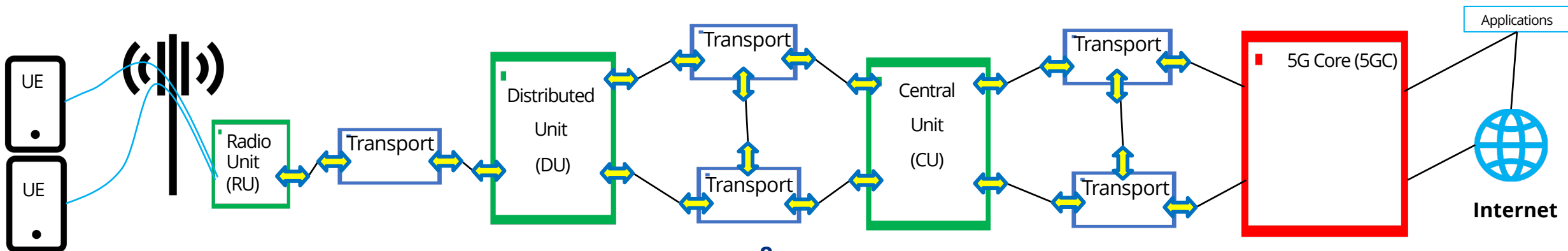
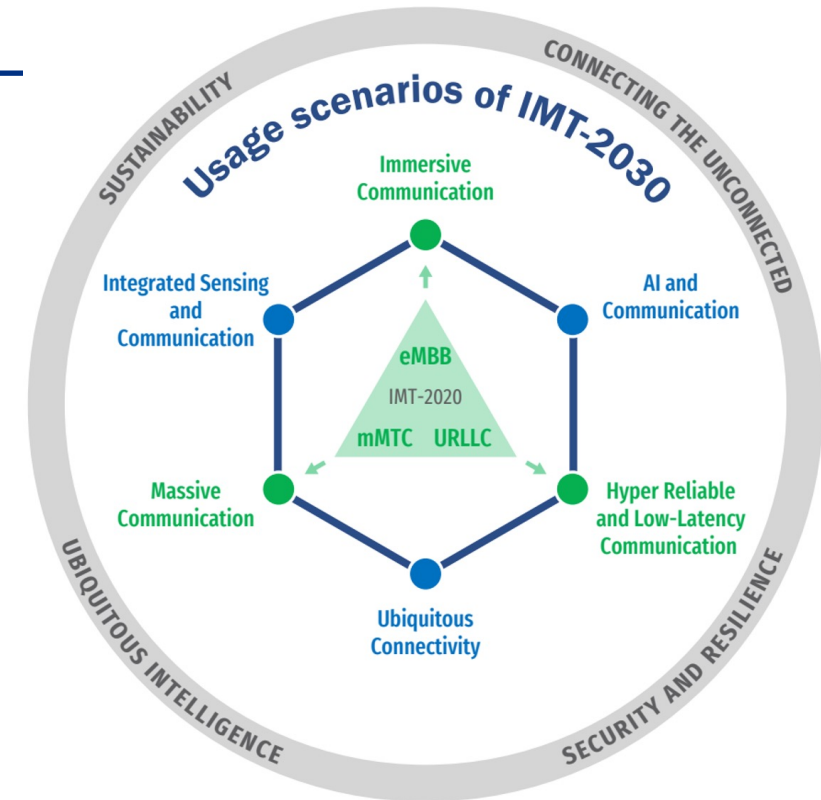

FIGURE 1

Usage scenarios and overarching aspects of IMT-2030



# Mobile Optics Background II

- To meet eMBB demands, large pieces of spectrum are allocated/planned for 5G
  - See table to the right for example bands up to 100 MHz
- 6G is looking into new and even wider bands
  - Centimetric (7-20 GHz) and sub-THz (92-300 GHz) ranges
  - Possibly 1 GHz bands and beyond
- With such wide spectrum, the RU peak data rates are up to ~50 Gbps for 5G and beyond 100Gbps for 6G
- As the mobile transport network handles multiple RUs, the mobile optical solutions need to handle  $N \times 25 / 50 / 100$  Gbps
  - See ITU-T Rec G.8300 Fig 9
  - Mobile backhaul aggregation needing 400 Gbps and beyond

Band	Duplex	$f$ (MHz)	Uplink [MHz]	Downlink [MHz]	Channel bandwidth [MHz]
LTE B4	FDD	1700	1710 – 1755	2110 – 2155	1.4, 3, 5, 10, 15, <b>20</b>
LTE B7	FDD	2600	2500 – 2570	2620 – 2690	5, 10, 15, <b>20</b>
LTE B40	TDD	2300	2300 – 2400		5, 10, 15, <b>20</b>
NR n41	TDD	2500	2496 – 2690		10, 15, 20, 30, 40, 50, 60, 80, 90, <b>100</b>
NR n78	TDD	3500	3300 – 3800		10, 15, 20, 25, 30, 40, 50, 60, 70, 80, 90, <b>100</b>

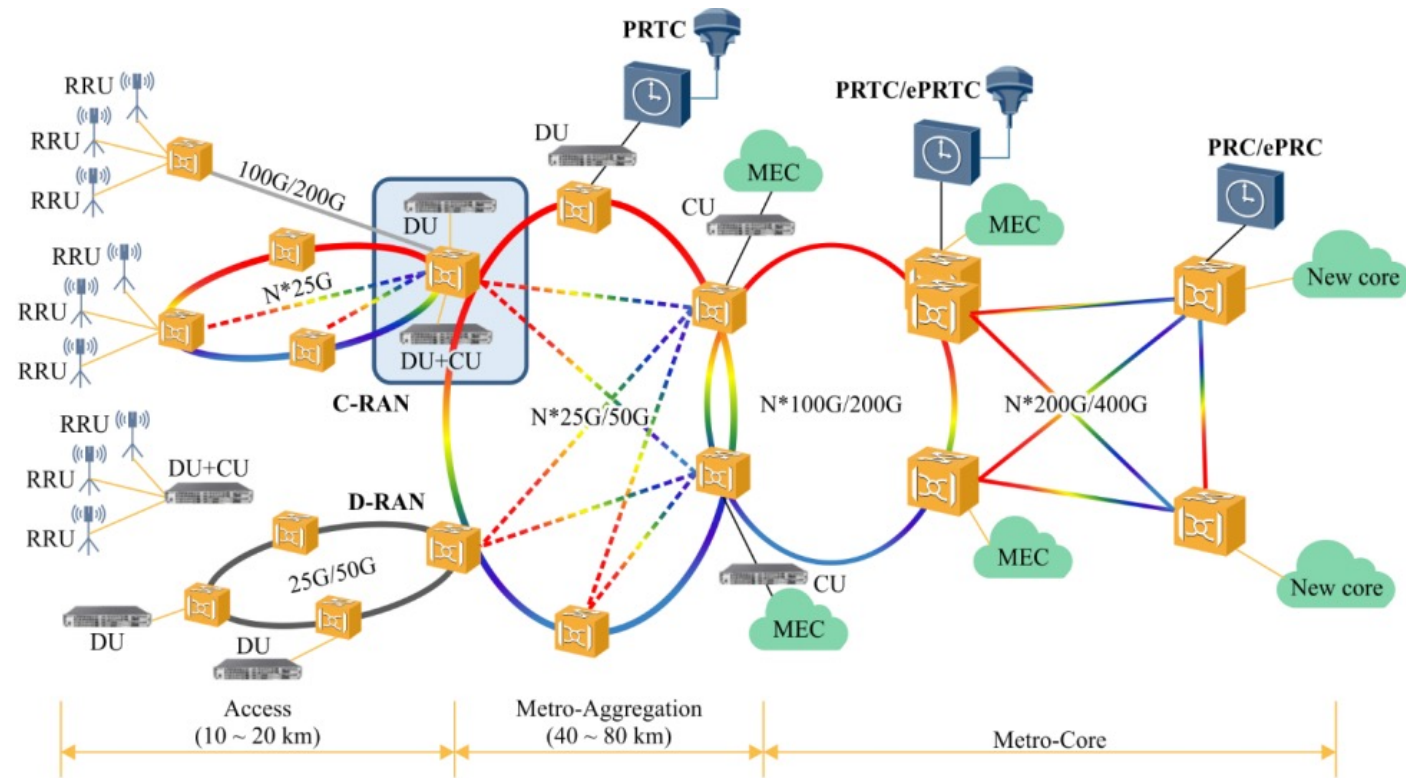

# MOPA Motivation and Blueprints

- MOPA aims to increase the **shared & common view** for the optical solutions needed for mobile transport
  - **Technological and Architectural impact** - Focus the architectures and technologies towards the most relevant needs
  - **Cost impact** – Reducing cost for operators, system vendors and optical pluggables suppliers by selecting the right solutions at high volumes
  - **Availability impact** – Assuring that the right solutions are commercially available at the right time and cost, not impairing the roll-out of 5G and future 6G



SFP+/28/56/112  
(10, 25, 50, 100 Gbps)

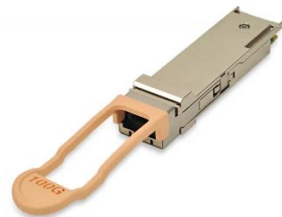

QSFP28/56/112/DD  
(100, 200, 400 Gbps)

An improved common understanding and focus can be achieved by making **mobile optical blueprints**

Clear optical pluggable needs for operators, systems vendors and optical pluggable suppliers  
Create an eco-system to ensure timely, cost-efficient, and optimized architectures

## Mobile optical blueprint =

Network solution description documenting a use case with the optical pluggables and passive optical components (WDM mux, splitter etc) implementing that use case, with high level optical requirements

# MOPA – Scope of Technical papers

- **Mobile transport: networks connecting radio access network (RAN) equipment**
  - Radio Units (RUs), Distributed Units (DUs) and Centralized Units (CUs).
  - Packet equipment (fronthaul gateways, cell site gateways etc), WDM transponder shelves.
  - Most important RAN deployment cases and best suited optical solutions with pluggables.
  - Optical Pluggables: front-panel pluggable optical transceivers SFP+, SFP28, SFP56, SFP112, QSFP28, etc.
- **The MOPA papers fill a need not previously covered:**
  - Only focused on mobile transport.
  - Lists and describes the high-level general requirements for mobile optical solutions and pluggables.
  - Shorter term and not architecturally focused.
  - Covers all the relevant mobile transport deployments cases, not only specific needs.
  - Working with SDOs: Reuses/references existing standards. Makes contributes from a mobile optics perspective.

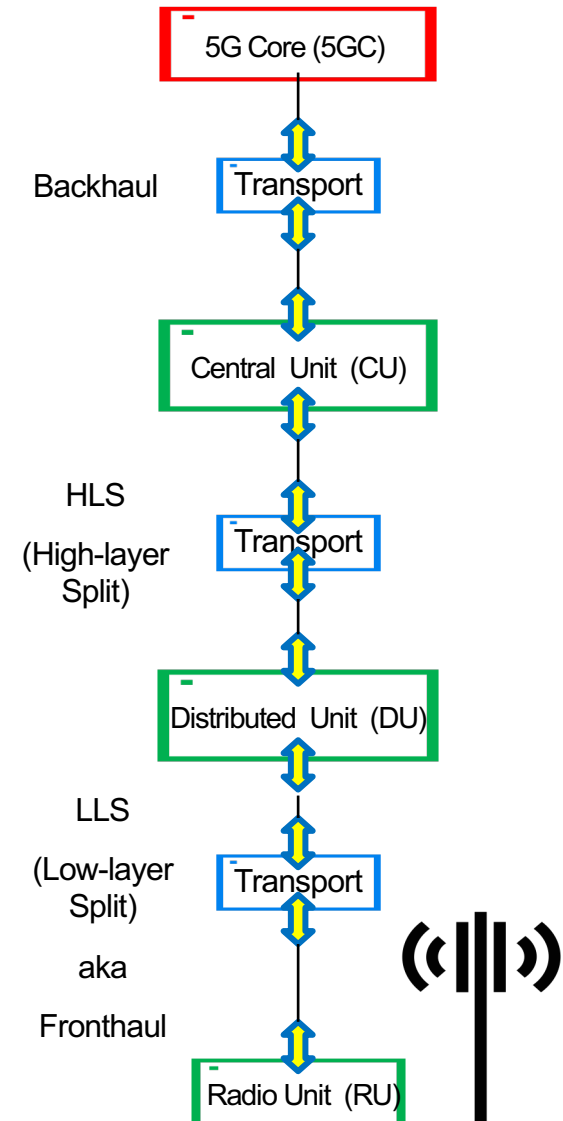

# MOPA Benefits

---

## Mobile network operators

Get a **better understanding** of the RAN **technology evolution** and corresponding optical transport technology evolution.

Have a **clearer**, more coherent and consolidated **message** from the industry: Have better foresight for choosing and protecting network technology investments. **Reduce risk** for interworking issues.

The **MOPA Operator Advisory Board can directly impact** the MOPA work by making work item proposals, MOPA conf talks etc.

## RAN systems vendors

**Drive better understanding** and alignment of the global requirements for the next gen mobile optical transport and optical pluggable needs.

Get the **right set of optical pluggable variants** for improved time to market, fewer variants at higher volumes to reduce cost, and lower product development uncertainty/risk with improved R&D efficiency.

## Pluggable vendors

Get a **clearer** and more coherent **message** from the market, and global industry direction, which will increase the foresight (incl volume and timing indications) and lower the product development uncertainty/risk with improved R&D efficiency.

Have a **stable** and sustainable global technology **supply chain**.

**Improve the eco-system understanding** of the cost-efficiency and time to market aspects vs product requirements and complexity.

# MOPA Blueprints

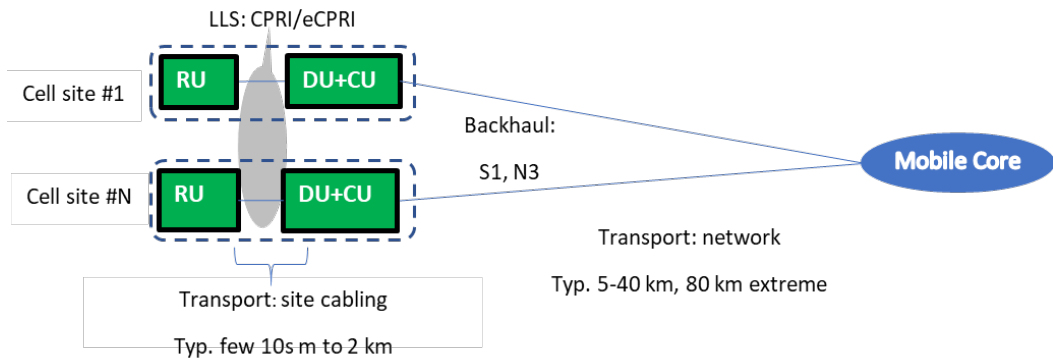

## DRAN LLS (fronthaul) Blueprints

- Up up to 2 km dual or BiDi gray fiber, 10/25/50 Gbps

## DRAN Backhaul Blueprints

- Up to 40 km
- Gray dual or BiDi (typ.  $\geq 10$  km), 10/25 Gbps
- Packet aggregation, 10/25/100 Gbps
- WDM aggregation, 10/25 Gbps
- GPON, 10GPON

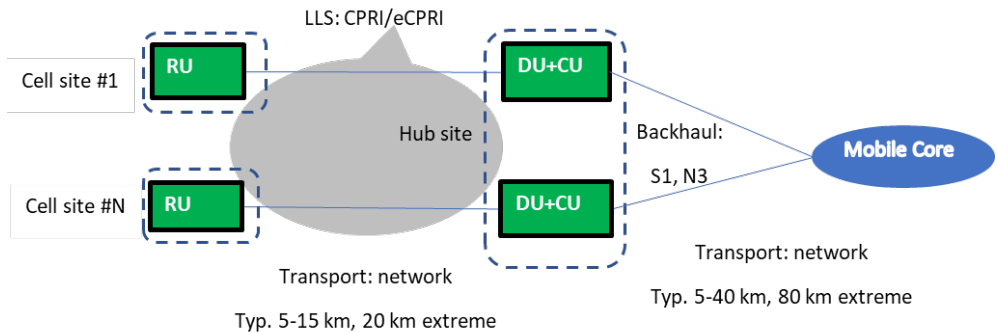

## CRAN LLS (fronthaul) Blueprints

- Up up to 15 km dual or BiDi gray fiber, 10/25/50 Gbps
- Packet aggregation, 10/25/100 Gbps
- WDM aggregation, 10/25 Gbps

## CRAN Backhaul Blueprints

- Up to 40 km
- Gray dual or BiDi (typ.  $\geq 10$  km), 10/25 Gbps
- Packet aggregation, 10/25/100 Gbps
- WDM aggregation, 10/25 Gbps

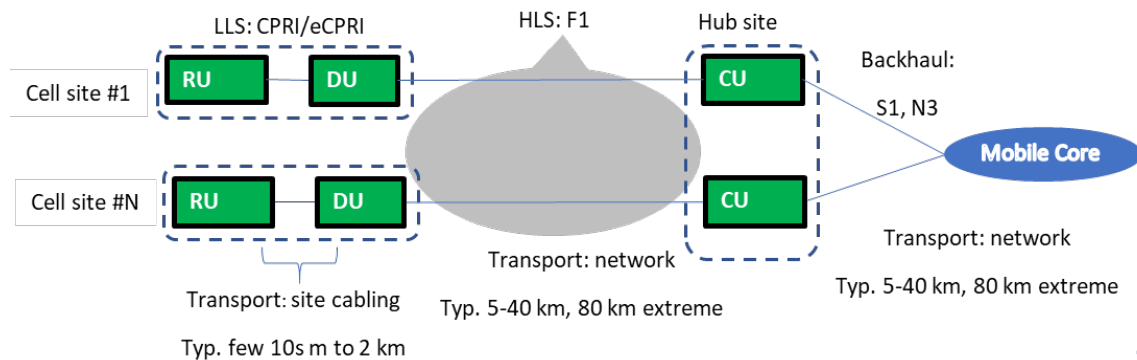

**Virtual RAN** (ie with DU and CU split in different locations ) is used for both for DRAN and CRAN.

Similar requirement as for backhaul above.

# Challenges for future mobile networks

- **RUs need SFPx formfactor** with
  - Low power consumption - max 2.5 W
  - High(er) temperatures - I-temp (and higher)
  - Long life span - 15 years
- **Increased data rates**
  - LLS (fronthaul) RU and DU gray → 50G, 100G
  - ~~Uni~~ **BiDi** to save fiber need to combat chromatic dispersion and reflections/multi-path interference
- **O-band vs C-band for WDM**
- **"Coherent lite"** - Coherent technologies for mobile: small formfactor/power, ~~uni~~ **BiDi**, short reach:
- LLS (fronthaul) **Distances: →30km+**
- Increasingly **tight timing synchronization** need characterization of impact from optical pluggables
- Easier operations with better network management and automation

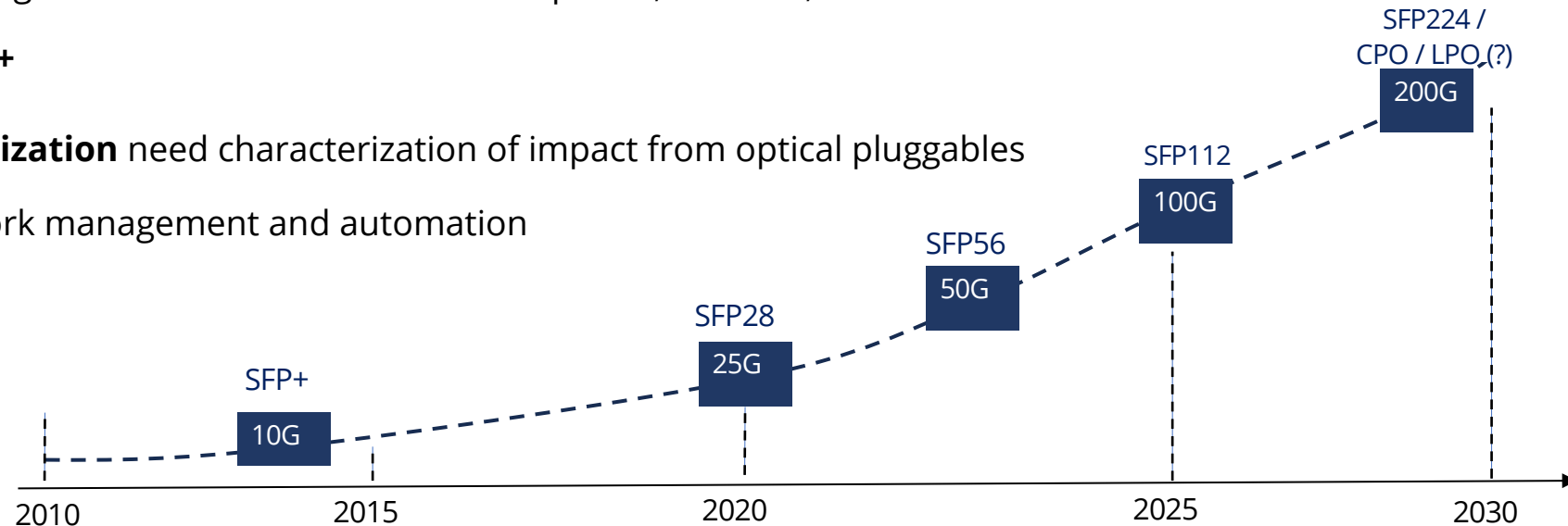

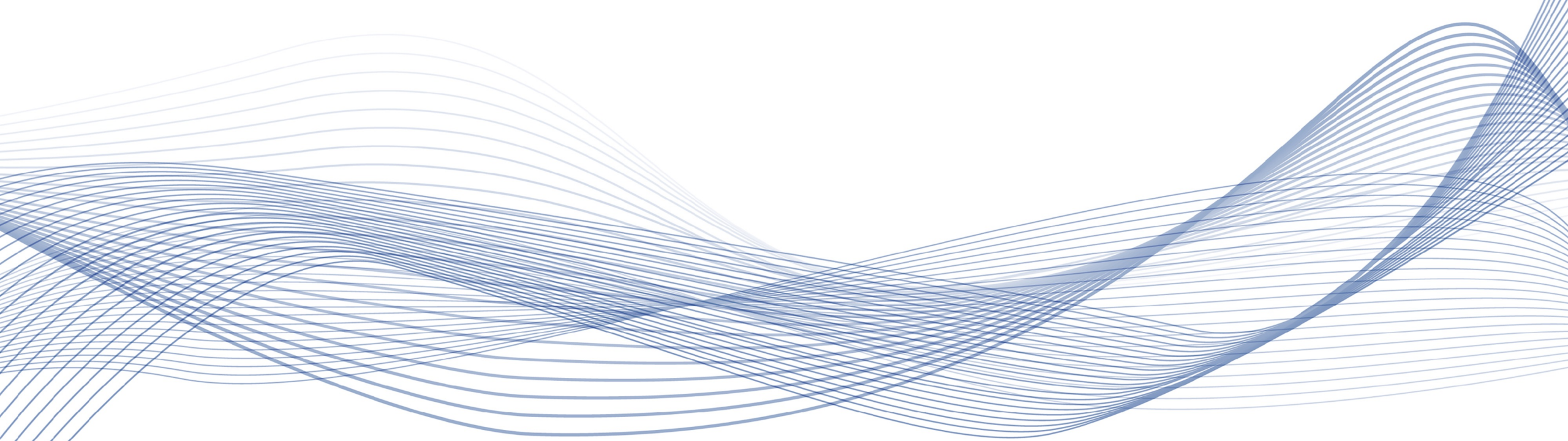

Copyright © 2023