



Mobile Optical Pluggables Alliance (MOPA)

Technical paper
Version 2.1
March 9, 2023

Authors (in alphabetical order)

Alberto Artuso³
Allard van der Horst⁶
Antonio Tartaglia¹
David Sinicrope¹
Giacomo Losio²
Giampaolo Bendelli²
Fabio Cavaliere¹
Fengliang Tang³

François Fredricx⁴
James Kannan³
Jun Pan⁵
Justin Abbott²
Ken Cockerham⁵
Kengo Matsumoto³
Kenneth Jackson³
Lieven Levrau⁴

Ole Reinartz⁴
Raza Khan⁶
Ronald Heron⁴
Ryo Kuwahara³
Uwe Schmiade⁴
Stefan Dahlfort¹
Steven Buchinger⁶

(1) Ericsson, (2) Lumentum, (3) Sumitomo Electric, (4) Nokia, (5) Coherent, (6) Semtech.

1. Executive summary

The spectrum allocations for the 5th generation mobile systems are growing as well as the rollouts of live 5G networks. These require transport network capacity growth, resulting in an urgent and significant need for high-capacity and cost-effective optical solutions as part of those 5G transport networks.

Currently, however, there is a lack of a shared and common view for the optical solutions needed for mobile transport [OptConn]. This has several implications:

- Technological and architectural: a plethora of different architectures and technologies.
- Cost: challenging choices for operators, system vendors and optical pluggables suppliers to focus on the most relevant needs.
- Availability: the right solution may not be commercially available at the right time and at the right cost point.

An improved common understanding and focus can be achieved by making mobile optical blueprints resulting in:

- Clear optical pluggable needs for operators, systems vendors and optical pluggable suppliers.
- An eco-system ensuring timely, cost-efficient, and optimized architectures.

By mobile optical blueprint we mean a network solution description documenting a use case with the optical pluggables and passive optical components (wavelength division multiplexing (WDM) mux, splitter, etc.) implementing that use case, with high-level optical and pluggables requirements. The Blueprints in this paper—nineteen in total—cover all globally relevant deployment variants for distributed radio access networks (DRAN), centralized RAN (CRAN) and virtualized RAN (VRAN) for the links connecting the radio units (RUs) with distributed units (DUs), DUs with centralized units (CUs), and CUs with the mobile core.

In light of new needs for mobile optical networks, this 2.1 version makes updates and additions to several areas: Chapter 5 includes new paragraphs on the 6G evolution, Section 6.12 introduces a new description on optical pluggable qualification from a system vendor perspective, Appendix B adds new details on optical pluggables with respect to their impact on tight transport synchronization, Annex A adds new details for a 50 Gb/s (and beyond) 48 channel DWDM system in O-band, and finally Annex B adds details to an improved channel, message types and storage memory maps for remote management of optical modules.

Contents

1. Executive summary	2
2. Introduction, purpose and scope	6
3. Acronyms	7
4. Legend and nomenclature	9
5. Background: 5G, 6G evolution and optical impact	12
6. Generic optical solutions requirements in mobile transport networks	16
6.1. Operating temperature and power consumption classes.....	16
6.2. EMI and EMC	17
6.3. Latency.....	17
6.4. Synchronization.....	17
6.4.1. Impact of optical pluggables on synchronization.....	17
6.5. Support of multiple bit rates	17
6.6. Form factor standards	18
6.7. Connectors: UPC, APC	18
6.8. Tunable and automatic self-tunable DWDM pluggables	18
6.9. Loss budget (channel insertion loss) and chromatic dispersion	19
6.10. Lifespan of optical pluggables.....	21
6.11. Remote optical module management.....	21
6.12. Optical module system vendor qualification, interoperability and the role of MOPA 22	
7. Mobile Optical Solution Blueprints for LLS in Distributed RAN (DRAN)	23
7.1. Overview.....	23
7.2. DRAN Optical Blueprints.....	26
7.2.1. 2 km RU-DU direct parallel fibers, dual and BiDi fiber Blueprint.....	26
7.2.2. 10 km RU-DU direct parallel fibers, dual and BiDi fiber Blueprint	27
8. Mobile Optical Solution Blueprints for LLS in Centralized RAN (CRAN)	28
8.1. Overview.....	28
8.2. CRAN Optical Blueprints	31
8.2.1. 15 km RU – DU direct parallel fibers, dual and BiDi fiber Blueprint.....	31
8.2.2. 10 km RU – DU, passive CWDM over a single fiber Blueprint.....	32
8.2.3. 15 km RU-DU, passive DWDM over a single fiber Blueprint	33
8.2.4. 15 km RU-DU, passive DWDM bus over a single fiber Blueprint	34

8.2.5.	15 km RU-DU, semi-active DWDM over a single fiber Blueprint.....	35
8.2.6.	2 km RU-DU packet multiplexing, dual or BiDi fiber Blueprint.....	36
8.2.7.	15 km RU-DU packet multiplexing, dual or BiDi fiber Blueprint.....	37
9.	Mobile Optical Solution Blueprints for Backhaul and HLS	38
9.1.	Overview.....	38
9.2.	Backhaul and HLS Optical Blueprints	40
9.2.1.	2 km DRAN intraoffice backhaul, direct parallel fibers, dual fiber Blueprint	40
9.2.2.	10 km DRAN backhaul, direct parallel fibers, dual and BiDi fiber Blueprint	41
9.2.3.	40 km DRAN backhaul, direct parallel fibers, dual and BiDi fiber Blueprint	42
9.2.4.	15 km DRAN backhaul, passive DWDM bus over a single fiber Blueprint.....	43
9.2.5.	2 km CRAN intraoffice backhaul, direct parallel fibers, dual fiber Blueprint.....	44
9.2.6.	10 km CRAN backhaul, direct parallel fibers, dual and BiDi fiber Blueprint.....	45
9.2.7.	40 km CRAN backhaul, direct parallel fibers, dual and BiDi fiber Blueprint.....	46
9.2.8.	15 km CRAN backhaul, passive DWDM over a single trunk fiber Blueprint	47
9.2.9.	20 km DRAN Backhaul and HLS with TDM-PON, Separate ONU box Blueprint..	48
9.2.10.	20 km DRAN Backhaul and HLS with TDM-PON, Pluggable ONU.....	49
10.	Summary of Optical Pluggables vs. Blueprint	50
11.	Summary of important technologies, capabilities, and components not yet available	53
11.1.	Optical transceivers operating at high temperature.....	53
11.2.	Cost effective high-capacity transceivers.....	53
11.3.	Pluggable optical amplifiers and dispersion compensators	54
11.4.	Cost-effective tunable filters and wavelength switches	54
12.	Solutions under evaluation and future work.....	55
12.1.	LLS using TDM-PON with separate ONU box	55
12.2.	LLS using TDM-PON with pluggable ONU.....	56
12.3.	Higher speed TDM-PON technologies.....	56
12.4.	LLS using semi-active DWDM wavelength multiplexed links over a power splitter ODN (WS-WDM-PON).....	56
12.5.	LWDM.....	57
12.6.	50 Gb/s xWDM 15 km LLS blueprint	58
13.	Conclusion	59

14. References	60
Appendix A: Referenced Physical Layer Standards Exceptions for MOPA Blueprints ..	62
Appendix B: Optical pluggable performance for tight synchronization	70
1. Introduction - Impact of pluggables on transported time synchronization.....	71
2. Factors impacting PTP accuracy.....	71
3. The impact of optical pluggables in link propagation delay asymmetries	73
4. "Link" vs. ITU-T "node" views	74
5. Eliciting transceiver-level requirements from node-level class.....	76
6. A methodology define propagation to delay accuracy classes of optical pluggables.....	78
6.1 Structure of the additional EEPROM data content for propagation delay characterization	79
6.2 Pluggables propagation delay characterization principles.....	79
7. An example of link cTE budgeting.....	81
8. Classes for TDM-PON optics	83
9. References.....	83
Annex A: 50 Gb/s xWDM 15 km LLS blueprint	84
1. Implementations under study.....	85
2. Candidates of wavelength grid in O-band vs Four-wave mixing penalties	86
3. Preliminary Blueprint.....	90
4. References.....	91
Annex B: Remote optical module management	93
1. Description of the application	94
2. Message channel characteristics	95
3. Frame structure and message types.....	96
4. SFP memory pages and registers	97
5. Operations enabled by the message channel	98
5.1 The value and standardization of remote monitoring and management of optical modules.....	98
5.2 Proposed remote-DDMI method.....	98
5.3 Autonomous module tuning.....	98
5.4 Proposed remote tuning method.....	99
6. References.....	99

2. Introduction, purpose and scope

From the International Mobile Telecommunications (IMT) 2020 vision [M2083] and resulting global and national efforts, the spectrum allocations for 5th generation mobile systems are growing and, consequently, also the transport capacity needs.

To better support the industry to optimize efficiency and time plans, this technical paper aims to describe uses of optical technologies and solutions across mobile transport in a clear way, as elaborated below.

This document is describing and clarifying what the authors think is needed for the mobile RAN equipment for optical pluggables. This description makes it clear what function is needed and lowers the barrier to entry by making it clear what to develop for the RAN equipment environment without wasting time and investment on unnecessary solutions for which there is no demand. Ideally this would result in robust, competitive offerings of optical components and solutions for the mobile environment to the ultimate benefit of consumers.

By mobile transport we mean networks to connect RAN equipment such as RUs, DUs and CUs, including eNodeB and gNodeB, and also transport equipment such as cell site gateways and active WDM equipment dedicated to mobile traffic¹.

This paper outlines important RAN deployment cases (see e.g. [G8300]) and the optical solutions best suited to these cases. The solutions in this paper are called mobile optical solution blueprints, or just Blueprints, encompassing the optical technologies—mainly optical pluggable modules but also accompanying components such as WDM filters—best suited to satisfy deployment needs. Optical pluggables are defined as front-panel pluggable optical transceivers in popular form factors like SFP+, SFP28, QSFP28, etc. and the Blueprints are intended as global solutions, i.e., as generic as possible to cover a wide range of network scenarios.

This paper organizes and integrates existing standards and implementation agreements produced by Standards Development Organizations (SDO), Industry Fora and multi-source agreements (MSAs), where the Blueprints cover the different technical aspects, forming a broad description of optical solutions useful and important for mobile transport networks.

This paper will look at the mid-term future identifying new Blueprints and possible new standardization activities considered of strategic interest for mobile transport networks.

Another way to clarify the important optical solutions for mobile transport is to classify them according to

1. Important solutions with wide consensus in the mobile transport industry.
2. Solutions still discussed where the importance is not yet concluded/agreed.
3. Solutions with a wide consensus not seen as important in the mobile transport industry.

The paper mainly deals with the first category, with some examples of the second outlined in Section 12.









¹ In this document, RAN node terminology is reused from [TS38306], [TS38470] and [GSTR-TN5G].

3. Acronyms

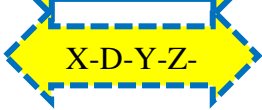
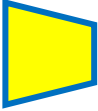
5G	5th Generation mobile networks, generic term for 5G system (or just the RAN part)
5GC	5G core, packet core part of 5G system
6G	6th Generation mobile networks
AI	Artificial Intelligence
AAV	Alternative Access Vendor
APC	Angled Polished Connector
AWG	Arrayed Waveguide Grating (optical DWDM multiplexer)
BiDi	BiDirectional (using a single fiber strand for both transmission directions from an optical pluggable pair, where the two directions use different wavelengths)
BER	Bit Error Rate
C-band	The conventional fiber transmission band, around 1550 nm (aka "3rd window")
CapEx	Capital expenditure
CD	Chromatic Dispersion
CO	Central Office
CRAN	Centralized RAN
CPRI	Common Public Radio Interface
CU	Central Unit
CWDM	Coarse WDM (20 nm wavelength spacing)
DCO	Digital Coherent Optics
DDM	Digital Diagnostics Monitoring
DFB	Distributed Feedback (laser)
DRAN	Distributed RAN
DWDM	Dense WDM (≤ 0.8 nm wavelength spacing in C-band)
DU	Distributed Unit
FP	Fabry-Pérot (laser)
FWM	Four-Wave Mixing
HLS	High-Layer Split
HTMC	Head-to-Tail Message Channel
IL	Insertion Loss
LC	Optical Connector
LLS	Low-Layer Split
LWDM	Local Area Network (LAN) WDM
MSA	Multi-Source Agreement
NR	New Radio, RAN part of 5G system
NRZ	Non-Return to Zero modulation
O-band	The original fiber transmission band, around 1310 nm (aka "2nd window")
ODN	Optical Distribution Network
ONU	Optical Network Unit (for TDM-PON)
OLT	Optical Line terminal (for TDM-PON)
OpEx	Operational expenditure
OPP	Optical Path Penalty
P2MP	Point-to-multipoint

P2P	Point-to-point
PAM4	Pulse Amplitude Modulation, 4 levels
Phy	Physical layer (optical)
Pkt	Indicates a node for packet switching and aggregation. May include mapping CPRI to packet, TDM to packet, etc.
PTP	Precision Time Protocol
QSFP	Quadruple-density Small Form Factor Pluggable
RAN	Radio Access Network
R-DDMI	Remote – Digital Diagnostics Monitoring Interface
ROSA	Receive Optical Sub-Assembly
RU	Radio Unit
SDO	Standards Development Organization
SNR	Signal to Noise Ratio
SFP	Small Form-factor Pluggable
STO	Self-Tuning Optic
TDP	Transmitter Dispersion Penalty
TDECQ	Transmitter Dispersion Eye Closure Quaternary
TOSA	Transmit Optical Sub-Assembly
UC	Use Case
VRAN	Virtual RAN
WDM	Wavelength Division Multiplexing. In a node, WDM indicates an active WDM equipment, also known as a WDM transponder
WL	WaveLength
WR	Wavelength Routed
WS	Wavelength Selected

4. Legend and nomenclature

	RAN Network Element
	Transport node: WDM or Pkt
	Optical Pluggable of type X-D-Y-W-Z, industrial temperature range ("I-temp")
	Optical Pluggable of type X-D-Y-W-Z, commercial temperature range ("C-temp")
	Optical (passive) multiplexer, industrial temperature range ("I-temp")
	Optical (passive) multiplexer, commercial temperature range ("C-temp")
	Fiber (generic)
	Fiber pair
	BiDi fiber (single fiber strand)
	Optical power splitter
	Pluggable device with integrated Transport node functionality and optics

The optical pluggable type in the icons above is meant to provide an indication at a glance of the category to which the transceiver belongs. It is meant to be a compact and not all-encompassing description: detailed characteristics are provided in the optical Blueprints description in sections 7-9, with further details in *Appendix A: Referenced Physical layer Standards Exceptions for MOPA Blueprints*. The semantic of the different type fields is reported in Table 1.

X Bit rate	D Distance	Y1 Wavelength region(s)	Y2 WDM grid	Y3 Number of wavelength s/ fiber strand	W Fiber mode 1=BiDi 2=dual	Z Form factor
10G	2 km	O (1260-1360 nm)	G – gray	1	1	SFP+
25G	5 km	E (1360-1460 nm)	(wavelength generic)	2	2	SFP28
50G	10 km	S (1460-1530nm)	B1 – BiDi 1270nm/1310nm	4		SFP56
100G	15 km	C (1530-1565nm)	B2 – BiDi 1270nm/1330nm	6		SFP112
200G	20 km	L (1565-1625nm)	B3 – BiDi xxxx / yyyy nm	8		QSFP+
400G	40 km	“*” (all bands, only for CWDM)	L – LAN-WDM (4.5nm)	12		QSFP28
GPON	80 km		D – DWDM (100 GHz, 0.8nm)	16		QSFP56
XGSPON			DL – DWDM with wavelocker (50 GHz, 0.4nm)	48		QSFP-DD
25GSPON			C – CWDM (20nm)	96		QSFP-DD56
						SFP-DD
						SFP-DD56
						DSFP
						DSFP56
						(prefix T is used for tunable)

Table 1: Optical pluggables codes nomenclature².

Some examples of using this nomenclature are illustrated below:

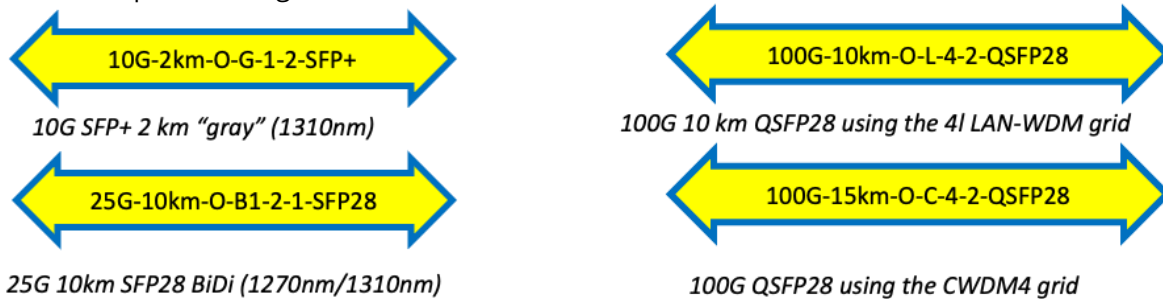

Figure 1: Example of icons and codes for “client” pluggables.

² It should be noted that some values and variants are not yet used for the Blueprints of this paper, e.g. the distances 5, 20 and 80 km.

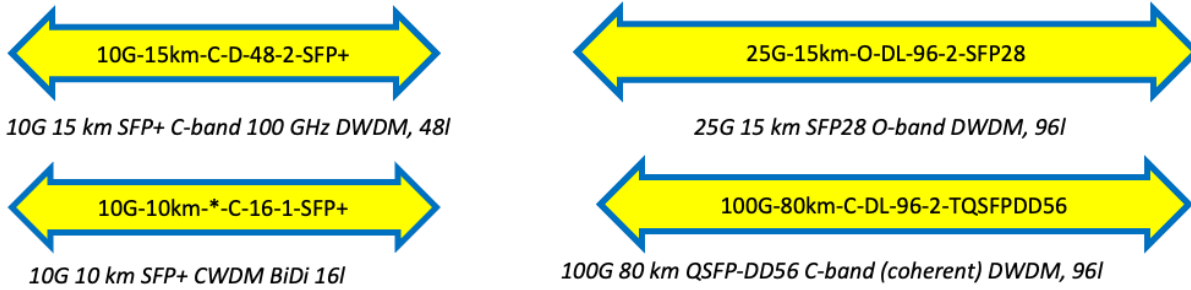
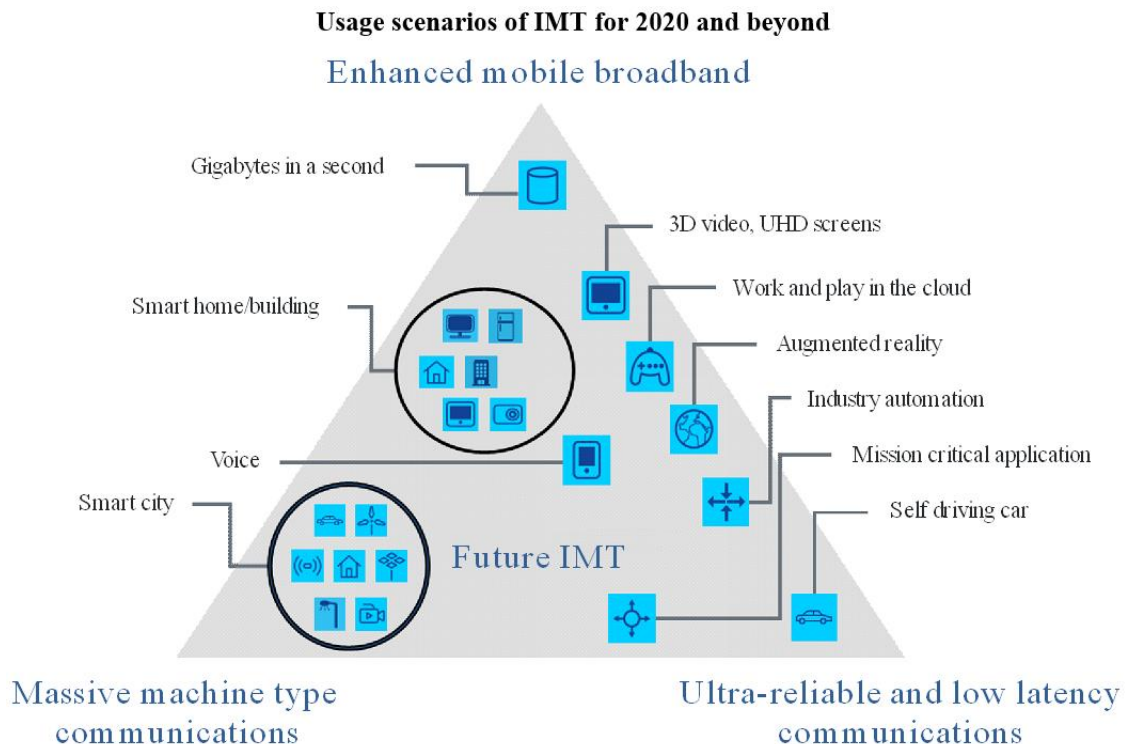

Figure 2: Example of icons and codes for "line" pluggables.

5. Background: 5G, 6G evolution and optical impact

With 5G research starting in the early 2010s [Wiki5G], and standardization efforts in 3GPP and ITU starting a few years later, the goals were to provide an enhanced mobile broadband experience as well as add capabilities for very scalable cellular networks for massive machine type communications (MMTC), and ultra-reliable and low-latency communications (URLLC). This is described in ITU-R M.2083 [M2083] and illustrated in Figure 3.



M.2083-02

Figure 3: IMT 2020 vision from ITU-R M.2083.

For the first goal, much larger pieces of spectrum are planned for 5G compared to LTE (see [LTEbands], [NRbands]) and bands can be combined for even more spectrum. With such a wide spectrum, the peak data rates for a radio unit can reach well beyond 10 Gb/s (see Section 4.1.2 in [TS38306]). Thus, the physical line rates for the optical pluggables used in radio units must be at least 10 Gb/s, often 25 Gb/s with 50 Gb/s and 100 Gb/s as next steps. Another driving factor is the consolidation of RAN baseband processing, performed by distributed units (DUs), to fewer locations: DUs are moved from the cell sites to central locations. Centralized RAN (CRAN) deployments started even before 5G and are steadily continuing also with the addition of small cells. Having said that, DRAN is today the dominant deployment variant. In CRAN, due to the longer distance between RUs and DUs, the interconnect is no longer simply cabling at the mobile site but becomes a transport network, making it more challenging to meet stringent

latency requirements between RU and DU and growing in complexity and cost. A generic name for the interface between RU and DU is Low-Layer Split (LLS, [TS38801]), where CPRI and eCPRI are common connectivity protocols, encapsulated in IP and Ethernet. High-Layer Splits (HLS) and the 3GPP F1 transport interface [TS38470] allow the partitioning into DU and CU, resulting in an architecture commonly referred to as virtual RAN3. Requirements for F1 transport are similar to the interfaces between RAN and the mobile core, i.e. S1 and N3 (for EPC and 5GC, respectively), commonly called backhaul [GSTR-TN5G].

While commercial 5G networks are being deployed worldwide and the technology and capabilities are continuously evolving, the research and development of the 6th generation mobile networks is gaining momentum. Figure 4 below shows a proposed timeline: 2023 includes visions and feasibility work, followed by work on technical requirements during 2024-36. It is expected that the first implementation specification from 3GPP will be released 2028 and the first commercial 6G network deployment will be done 2030.

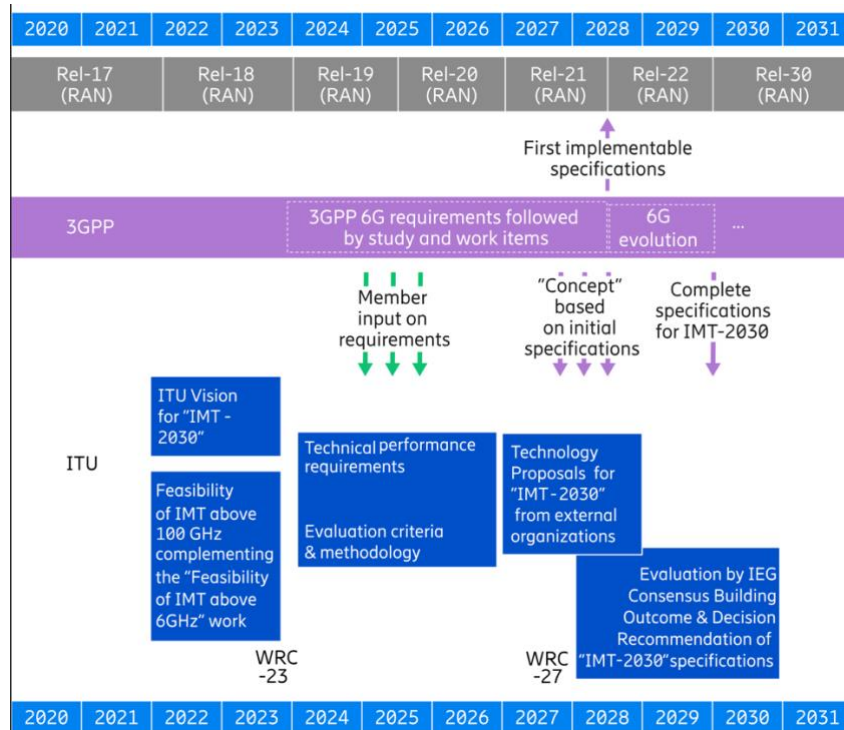

Figure 4: Ericsson proposed ITU-R and 3GPP timeline, simplified view from [ERI-6G-Spectrum].

So, what new capabilities will 6G bring? One improvement traditionally offered by new mobile generations is ~10x data rates. To achieve this, there's much work on securing new spectrum for 6G (see [ER-6G-Spectrum] for more details). But 6G is much more than just higher data rates: much work is currently invested in security/trustworthiness, sustainability, and AI/connected intelligence. The EU project Hexa-X (<https://hexa-x.eu>) is looking into these areas, and others in great detail over

³ It should be noted that virtualization is a technology and not an architecture, but since one popular technology choice is to virtualize the CU function, the term virtual RAN is common.

the next years. Figure 5 summarizes the different capabilities are technical areas being worked on by Hexa-X.

Looking into capabilities such as extreme experience and global service coverage, one can conclude that higher data rates with more antenna locations and lower latencies will be needed with 6G. This then naturally requires higher speed optics in greater volumes and with tightened control of the latency impact.

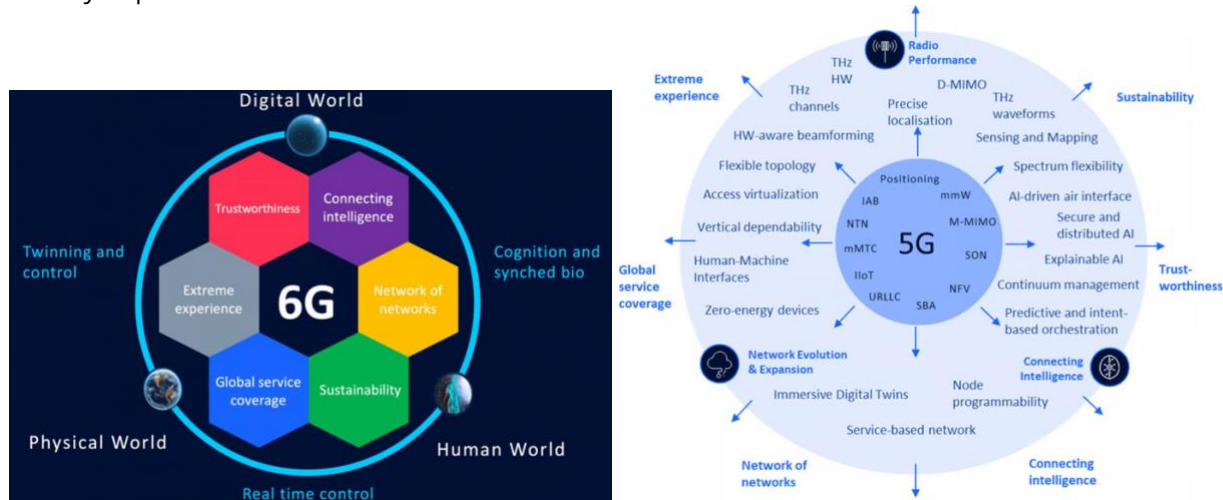

Figure 5: The illustration to the left shows the 6 different capabilities of 6G being addressed by the Hexa-X project. These go along the dimensions of the Human, Physical and Digital worlds. The illustration to the right details technical areas being studied. See [Hexa-X].

Figures 6, 7 and 8 below illustrate the architectures of DRAN, CRAN and virtual RAN, respectively⁴. A few things should be noted from the below figures:

- The illustrations are much simplified. For example, each cell site normally includes multiple RUs.
- All the architectures below have LLS, either locally at the site for DRAN and virtual RAN or spanning sites as in the CRAN case.
- While the below figures explicitly show that DU and CU may be collocated, the illustrations in the rest of this paper may be less explicit. Unless “CU” nodes are explicitly illustrated, the “DU” nodes may include the CU function as well.

⁴ In this paper, the network terms LLS and HLS are used instead of fronthaul, midhaul, x-haul etc., due to the ambition to be unambiguous and to use 3GPP terms whenever possible.

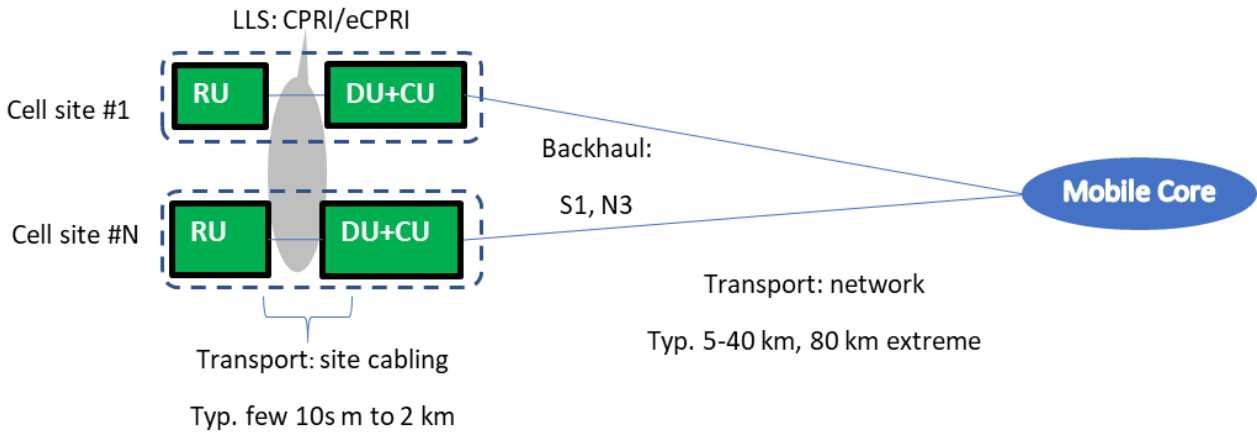

Figure 6: DRAN architecture. The LLS links are highlighted by the gray oval.

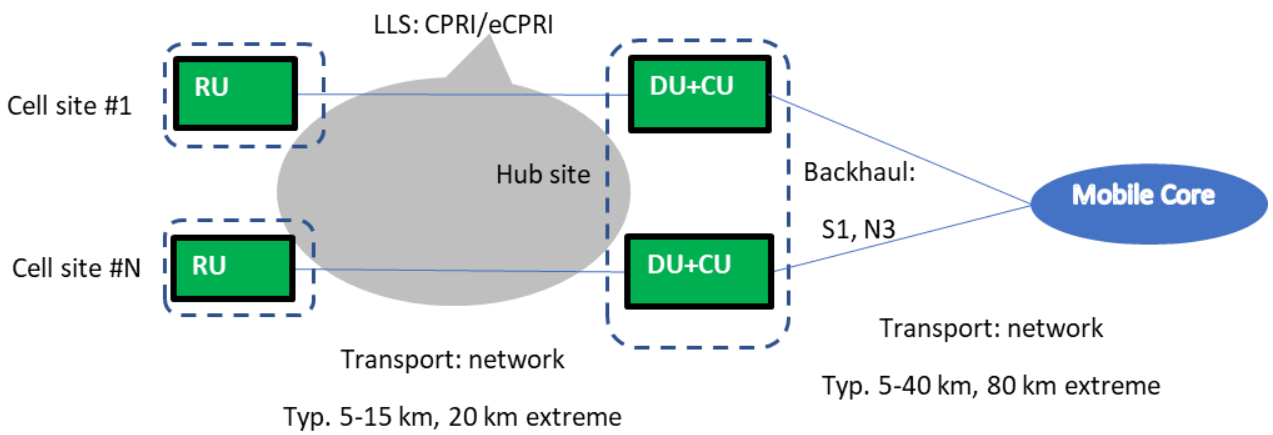

Figure 7: CRAN architecture. The LLS links are highlighted by the gray oval.

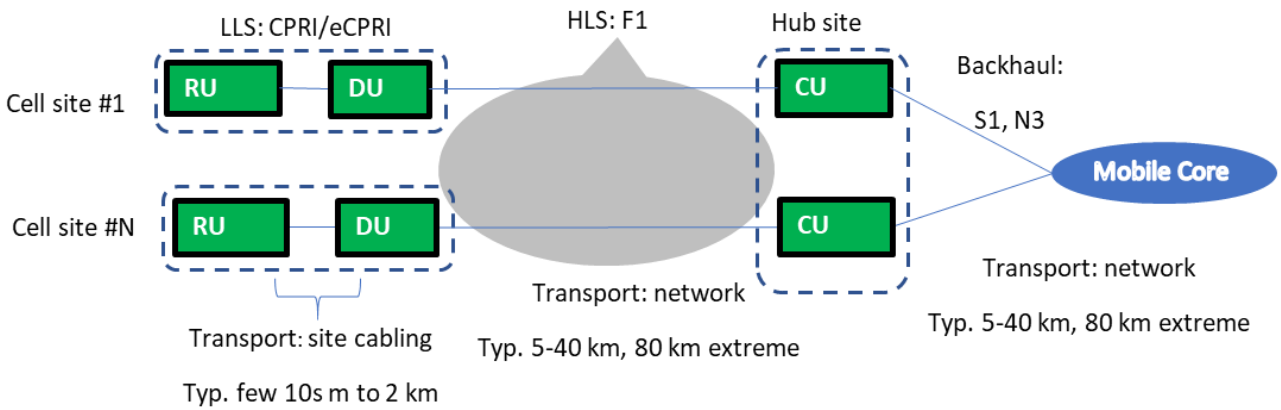

Figure 8: Virtual RAN architecture. The HLS links are highlighted by the gray oval.

6. Generic optical solutions requirements in mobile transport networks

The purpose of this section is to outline the specific requirements characterizing “radio-grade” optical solutions.

6.1. Operating temperature and power consumption classes

In mobile transport networks, optical pluggable modules can be used in RUs or packet nodes that are located outdoors, which requires a wide operating temperature range. While DUs may be deployed in temperature-controlled locations, especially for CRAN, it might be beneficial from an inventory, planning and testing perspective to use wide temperature optical pluggable modules also for DUs. Using wide temperature optics for indoor applications can add cost at the initial phases of the technology and product life cycle, but history and consolidated trends in the industry indicate that this cost addition disappears over time.

The typical requirement for outdoor-grade optical pluggables is the so-called “industrial case operating temperature range”, or “I-temp” for short, ranging from -40 °C to 85 °C. It is identified that a lower bound of -20 °C could provide cost advantages in certain scenarios: the definition of such scenarios and the intended transceiver behavior between -40°C and -20°C case temperature is for further study.

For certain applications with a high density of dissipated power, it could also be necessary to exceed the upper temperature limit, which may require alternative solutions. In this paper, we assume I-temp for all pluggables unless otherwise stated.

Following the methodology described in [OIF-Thermal], we can use the following power consumption classes (PC) which should not be exceeded to facilitate implementation and thermal management on host units.

Form factor	PC 1 [W]	PC 2 [W]	PC 3 [W]	PC 4 [W]	PC 5 [W]	PC 6 [W]
SFP/+/28	1	1.5	2.0	2.5	-	-
DSFP/SFP-DD	1	1.5	2.0	2.5	-	-
SFP56	1	1.5	2.0	2.5	-	-
QSFP28	1.5	2.0	2.5	3.5	4.0	4.5 ⁵
QSFP-DD	1.5	3.5	7.0	8.0	10	12

Table 2: Power consumption classes (PC) for pluggables, using the methodology in [OIF-Thermal].

The values and classes of Table 2 will be used for the Blueprints outlined in this paper.

Apart from thermal aspects, it’s important not to exceed these values because they are used to dimension the electrical power supply of the host boards.

⁵ BiDi DWDM QSFP28 can have up to 7 W power consumption.

6.2. EMI and EMC

EMI and EMC requirements at module level are particularly important, given the possible proximity of optical pluggables to RF receivers: in order to provide enough margin for system-level tests, it's not uncommon to require figures of 6 dB to 12 dB better than the applicable transceiver-level standards in [ETS-EMC] and [FCC15].

6.3. Latency

Particular care must be taken to limit the worst-case latency introduced by the optical pluggable (due to DSP, serialization, FEC encoding and decoding, possibly other manipulations like interleaving). As a general criterion, a contribution to single-ended latency in the order of a few μ s can be tolerated.

6.4. Synchronization

It is also important that potential sources of PTP timestamping inaccuracy are tightly controlled. Any effect, deterministic or stochastic, potentially leading to uplink/downlink propagation delay asymmetry, directly impacts the time error budget. The acceptable contribution of pluggables in point-to-point links to overall uplink/downlink delay asymmetry should be less than a few ns. For TDM-PON systems the delay is inherently asymmetric, and this is circumvented by a termination of PTP at the OLT, the use of TPS-TC (Transport Protocol Specific – Transmission Convergence), and generation of PTP at the ONU side.

6.4.1. Impact of optical pluggables on synchronization

In a packet transport network using PTP (precision time protocol) for synchronization distribution, PTP timestamping inaccuracy must be tightly controlled. Any effect, deterministic or stochastic, potentially leading to uplink/downlink propagation delay asymmetry in a link, directly impacts the time error budget. The acceptable contribution of pluggables in point-to-point links to overall uplink/downlink delay asymmetry should be a small percentage of the overall requirement for the full system. For TDM-PON systems the delay is inherently asymmetric, and this is circumvented by a termination of PTP at the OLT, the use of TPS-TC (Transport Protocol Specific – Transmission Convergence), and generation of PTP at the ONU side. In the case of TDM-PON the uplink/downlink propagation delays as such are allowed to be different but they must be estimated correctly for a precise distribution of Time of Day to the ONUs.

Appendix B "Optical pluggable performance for tight time synchronization" presents a detailed description of node level and link level aspects of accurate sync distribution via PTP, and of how the characteristics of optical pluggables can impact them. For this purpose, we propose a classification of delays of optical pluggables.

6.5. Support of multiple bit rates

The specific nominal bit rates which must be supported are part of the detailed Blueprints descriptions. In general terms, transceivers using internal re-timer ICs are expected to support "re-timer bypass" functions, to allow operation at lower bit rates.

6.6. Form factor standards

The aforementioned form factors are expected to be fully compliant with the relevant SFF MSA specifications in Table 3.

Name	Main specification	Low-speed and general electric specification	High-speed electric specification	Common management specification
SFP+	SFF-8083	SFF-8419	SFF-8418	SFF-8472
SFP28	SFF-8402	SFF-8419	CEI-28G-VSR, IEEE 802.3, 109B.3.2,4	SFF-8472
SFP56	SFF-8402	SFF-8419	CEI-56G-VSR, IEEE 802.3, 135G.3.2,4	SFF-8472
DSFP	DSFP MSA		CEI-28G-VSR	ACMIS (abridged CMIS)
QSFP28	SFF-8665	SFF-8679	CEI-28G VSR, IEEE 802.3 83E.3.2,4	SFF-8636
QSFP-DD	QSFP-DD MSA		CEI-56G VSR, IEEE 802.3 120E.3.2,4	CMIS (common management interface spec)

Table 3: Pluggable form factors and their standards.

The so-called *digital diagnostic monitoring* (DDM) in SFF-8472 and SFF-8636 is very important for observability of optical links, and the *internally calibrated* approach is nowadays almost ubiquitous in line card implementations. No standards exist yet for *remote* DDM, i.e., the possibility to access the DDM of a remote transceiver using the management interface of a local transceiver, using an out-of-band, low bit rate auxiliary communication channel. However, see Section 6.11 and Annex B “Remote optical module management” for a discussion on remote optical module monitoring.

6.7. Connectors: UPC, APC

Solutions must be able to work on outdoor fiber plants based on UPC/LC single mode connectors: thus, they must be able to tolerate a maximum discrete optical return loss of -50 dB⁶ [IEC61753]. The only exception to this rule is represented by PON solutions, which can also be based on APC/LC single mode connectors in some cases. Unless stated otherwise inside the detailed Blueprints description, UPC/LC single mode connectors must be assumed.

6.8. Tunable and automatic self-tunable DWDM pluggables

Currently, DWDM networks are utilizing either fixed wavelength or wavelength tunable transceivers. It is highly desirable that all DWDM applications described in this document rely on tunable transceivers, for inventory simplification and consequent reduction of the operational costs (no need to label or track fibers, only a single part number is required instead of 48⁷ or 96, easier forecasting and inventory management, less potential for stranded inventory at unused wavelengths). Sub-optimal solutions, where the transceiver can only tune over a subset of

⁶ It should be pointed out however, that such low values are difficult to assure in field environments, where return loss values of 35 dB are more realistic.

⁷ Used in this paper, reference [G.698.2] specifies a 48 channel 100 GHz grid with min central frequency of 191.4 THz, and max central frequency of 196.1 THz

wavelengths, can be acceptable as temporary solutions, if the cost gap between full-tunable transceivers and fixed wavelength transceivers remains too big.

Self-tunable transceivers add the capability to automatically set the transmission wavelength (*self-tune*) leading to further simplification of network installation and operation practices. This is usually achieved by means of a negotiation procedure between the transceivers at the two ends of the link, exploiting information conveyed through a signaling channel, which can be either in band prior to the start of traffic (e.g., using the same transmission protocol and frame of traffic data) or out of band (e.g., superimposing to the modulating signal an additional amplitude modulation at a low bit rate and low modulation depth). Both solutions have the advantage of being agnostic to the protocol used for transmitting the data (e.g., Ethernet or OTN).

Although customers understand the significant benefits of the self-tune feature, cross-brand units will not interoperate properly due to the proprietary Self-Tuning Optic (STO) schemes which have been designed and implemented by the various transceiver suppliers. Due to the increasing interest in these features, it is important to identify requirements and propose multi-vendor interoperable solutions for standardization.

An MSA for STO functionally has been made [SmartT] that enables reduction in OpEx and CapEx:

- Plug and Play feature means less technician time in the field.
 - No need to label or track fibers and no need to buy hundreds of tuning boxes to set the wavelength.
- Only 1 part number is required instead of 96.
 - Easier forecasting and inventory management.
 - Reduces the potential for stranded inventory at the wrong/unused wavelengths.

The self-tuning functionality will not require anything new from the host system and the host system can enable or disable this function.

6.9. Loss budget (channel insertion loss) and chromatic dispersion

In this document we focus on single-mode fiber. Compared to multi-mode fiber, single-mode fiber has clear advantages for the outside plant fiber with its much higher bandwidth-distance product, better tolerance to fiber bends, and lower cable cost. Pluggables for multi-mode fiber can be lower cost than corresponding for single-mode fiber, but that cost has historically been shown to diminish/vanish with volume. Moreover, I-temp tends to be challenging for low-cost multi-mode transmitters. Multi-mode can be interesting for short distance temperature-controlled data center environments. i.e., when using short patch-cords and active cables.

There are many standards for loss budgets, also called channel insertion loss, used in standards documents and the industry. Examples for cabled fiber and splice attenuation include:

- ITU-T G.652 [G.652] Table I.1: Cabled concatenated links incl splices: 0.5 dB/km 1260-1360 nm, 0.275 dB/km 1530-1565 nm
- Commercial example for SMF-28: max 0.35 dB/km 1285-1330nm, max 0.20 dB/km @ 1550 nm (excl. splices).
- ITU-T G.671: Fusion splice active alignment: 0.3 dB.
- ITU-T G.sup39: Cables installed after 2003, Fiber att. average 0.349 dB/km @ 1.3um, 0.205 dB/km @ 1.55um (incl. splices every 2 km).

For connectors (typ. LC assumed in this paper), examples include:

- ITU-T G.671: max 0.5 dB 1260-1360 nm.
- Commercial products: 0.25 - 0.5 dB.

The values above will in many cases over-engineer the optics, leading to higher component costs than necessary. Instead, this paper suggests a pragmatic approach to find a balance between high quality/reasonable margin and cost: 0.4 dB/km 1260-1360 nm (i.e. O-band), 0.25 dB/km 1530-1565 nm (i.e. C-band), connector loss of 0.5 dB.

We assume that there are up to four intermediate connector jumps for distances up to 20 km. For 40 km, since such long links may pass additional flexibility points, we assume up to six connector jumps.

In addition, it is customary for operators to allocate a small margin for maintenance reasons (e.g., degradation of fiber, new splices, bad connectors or minor fiber bends). Consequently, the following loss budget values will be used in this paper:

Distance	Fiber attenuation O-band (1260-1360 nm)	Fiber attenuation C-band (1530-1565 nm)	Connectors Insertion Loss	Maintenance Margin	Total Loss budget - P2P fiber O-band	Total Loss budget - P2P fiber C-band
≤ 2 km	0.8 dB	0.5 dB	2 dB (4x)	0 dB	2.8 dB	2.5 dB
10 km	4 dB	2.5 dB	2 dB (4x)	1 dB	7.0 dB	5.5 dB
15 km	6 dB	3.8 dB	2 dB (4x)	1 dB	9.0 dB	6.8 dB
20 km	8 dB	5 dB	2 dB (4x)	1 dB	11.0 dB	8.0 dB
40 km	16 dB	10 dB	3 dB (6x)	2 dB	21.0 dB	15.0 dB

Table 4: Loss budget values used in this paper. The total loss budget is sometimes called Channel insertion loss.

It should be noted that,

- the above values do not take into account the transmitter and dispersion penalties etc., which have to come on top of the loss values for a complete power budget specification. Thus, this paper does not deal with power budget specifications and the related transmitter and receiver requirements,
- the above total loss values are higher than those for IEEE 10GBASE-ER, 25GBASE-ER and 4WDM-40, due primarily to the maintenance margin being included. For further details, see Appendix A: Referenced Physical layer Standards Exceptions for MOPA Blueprints.

For 10G, we assume a BER of 10e-12, while for 25G and 100G we assume a BER of 5e-5. The latter assumes using FEC with RS(528, 514), i.e., the so-called "KR" FEC. The FEC functionality is implemented in the host system, not in the pluggable.

In some cases, a wavelength mux is required. Commercial values for the insertion loss vary in the range of 4.6 to 6.0 dB depending on the type (AWG vs TFF) and the design. For networks that employ a point-to-multipoint fiber infrastructure with passive power-splitting, i.e., a TDM-PON fiber network, the insertion loss of splitters must be added to the insertion loss values indicated for P2P fiber in Table 4.

Nominal wavelength mux and power splitter insertion losses are shown in the table below:

Component	CWDM Mux DeMux 6ch (TFF), Pair	DWDM Mux DeMux 48 ch (AWG), Unit	DWDM fixed OADM 6 ch (TFF) Pass / AddDrop, Unit	Power splitter 1:2	Power splitter 1:4	Power splitter 1:8	Power splitter 1:16	Power splitter 1:32	Power splitter 1:64
Insertion loss [dB]	4.5	5.5	0.6 / 3.0	3.5	7	10.4	13.9	17.4	21

Table 5: Insertion loss values for passive optical components used in this paper.

With a similar line of thinking, the value for Chromatic Dispersion (CD) used in this paper is 18 ps/(nm*km) for the C-band and 4 ps/(nm*km) for the O-band. An appropriate Optical Path Penalty (OPP) must be included in the network design to account for the impairments over a fiber distance taken together with any CD mitigation capabilities.

6.10. Lifespan of optical pluggables

Whatever the functional split and the architecture, antenna sites in RAN will remain geographically scattered as they must ensure the intended radio layer coverage. The number of antenna sites and their variety are very large: some antenna sites can be quite difficult and expensive to access, for instance tall cell towers. Geographical distribution of antenna sites also makes spare parts management and logistics an important operational cost. Therefore, lifespan and reliability of optical transceivers for RAN cannot be relaxed to a point they adversely impact whole network operation costs.

The lifetime of optical transceivers, defined as the period of time for which all requirements must be fulfilled, must be at least 15 years.

During the lifetime, it is also very important that the number of random failures expressed in FITs (number of failures per billion device hours) at high case operating temperature is very low. If converted from FITs to MTBF and expressed in years, the typical reliability figure required at high case temperature is normally *one order of magnitude larger* than the 'lifetime' figure.

6.11. Remote optical module management

Annex B "Remote optical module management" describes a messaging channel, a frame structure, a memory map, and a protocol that together enable the management of optical modules at the two ends of an optical "black link", either WDM or gray and single or double fiber. The term "black link" means that the internal details of the link are not defined here. In the tunable DWDM case, the requirement for end-to-end operation of the messaging channel is that the two module transmitters are tuned to the correct wavelength(s) so that messages sent by one module's transmitter will be received at the receiver port of the other module.

6.12. Optical module system vendor qualification, interoperability and the role of MOPA

System vendors of network equipment, such as RAN and transport equipment, need to ensure the network and system function and performance during the agreed life span – from contractual and/or public relations and/or critical infra perspectives. This includes also the pluggable optics being an integral part of the overall system. For an optical pluggable to function as intended in a system/box requires a number of optical pluggable tests and qualifications:

1. Meet the applicable available standards and specifications.
2. Fulfill additional functionality not standardized.
3. Module performance is consistent over subcomponent and design changes.
4. Unit variability (ie by tests, quality control and audits secure the module performance variation due to component and manufacturing spread).
5. Function as intended with the specific system/box for that specific network function and deployment type(s).

An industry effort such as MOPA feeds into areas number 1 and number 2, and in the case of MOPA, specifically for mobile optical pluggables. Areas number 3 and 4 requires a continuously adapting testing organization, which is outside the scope of MOPA. Number 5 requires system vendor expertise, continuously evolving with new products and features.

There is a common misconception/expectation that industry work and documentation, such as MOPA and other industry organizations, can produce specifications that include all the necessary information to qualify any optical pluggable towards any system box. The main complication is that the combined host equipment (e.g. RU or DU) and optical pluggable system function and performance, for example regarding EMI, must be tested together for the specific combination. Both host equipment and optical pluggables have continuous updates to hardware, firmware and software that may impact the combined function and performance. While many combinations may work for the base functionality in room temperate during a limited time, the target for critical infrastructure such as mobile networks, must be that all functionality works for all the environmentally conditions it is specified for during its whole life span.

From the above, it is fair to conclude that using “any pluggable for any system” is not feasible in the general case, as integration testing and type approval are essential to guarantee system performance, quality and stability.

The simple answer to the question “Why can’t I just take any optical pluggable and use in my system box?” is that one wouldn’t know how well the optical pluggable works for that system box over the intended life span. In case of any problems, the system vendor cannot help trouble shooting the problem since the optical pluggable is unknown with regards to its system related behavior. And to answer the follow-up question of “What should I do if there is a problem with a (by the systems vendor) non-qualified optical pluggable in my system?” the response would be that the first action would be to replace the non-qualified optical pluggable with an optical module qualified by the system vendor since this is helping the system reliability and the system vendor troubleshooting task.

7. Mobile Optical Solution Blueprints for LLS in Distributed RAN (DRAN)

7.1. Overview

DRAN is the original RAN deployment and is the most popular deployment method where the DU and RU are in proximity, often within a cell site. The figure below illustrates a simplified DRAN architecture.

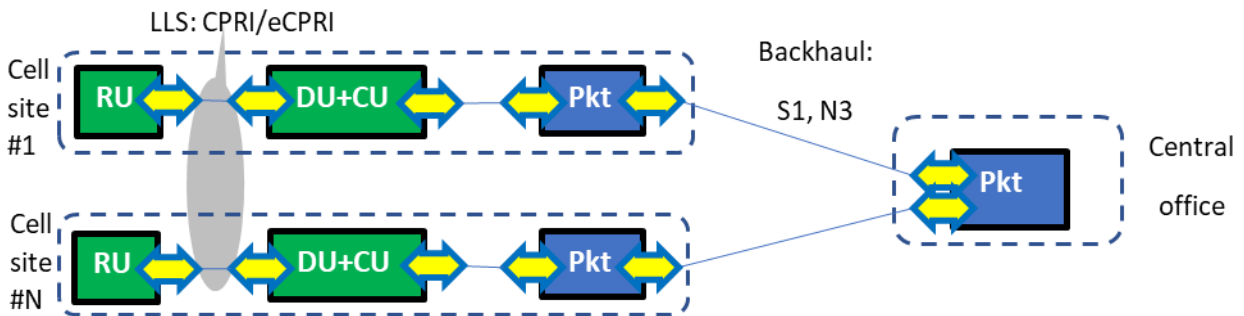

Figure 9: DRAN architecture with RAN nodes, transport nodes and optical pluggables.

Following the above, most of the DRAN DU-RU links are less than 300 m, with significant tails up to a few kilometers, as shown in the picture below.

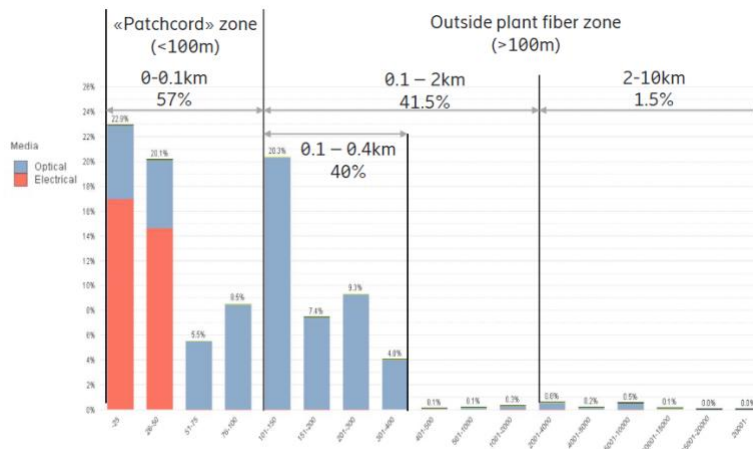

Figure 10: LLS link length distribution.

(source: Ericsson, by characterizing millions of LLS links in live networks).

The typical rooftop installation for macro base stations consists of three radios, with three antennas covering a 120° sector each, to provide omni-directional coverage. This structure is replicated on the same site when several frequency bands have to be supported: for instance, in 4G/LTE a typical deployment is 3x2 (three sectors, two frequency bands). Thus, the number of RU

pluggables required at a cell site tends to be a multiple of 3 or 6, with the same for the number of fibers or WDM channels (when used). For 4G/LTE-E deployments, considering typical radio configurations and capacities, the required LLS capacity per sector usually does not exceed 10 Gb/s.

With the adoption of 5G, capacity requirements have increased but the re-architecting of the radio base stations have exposed more bandwidth-efficient LLS transport interfaces, thus limiting the potential explosion of capacity. For 5G NR deployments, considering early radio configurations and capacities, the required LLS capacity per sector usually does not exceed 25 Gb/s today but the adoption of AAS and higher frequency bands will push the required LLS capacity further [GSTR-TN5G].

The two typical scenarios of fiber resources availability in DRAN are reported below:

In the majority of cases, DUs (or DU+CU) are located in close proximity of the RUs (cell towers or rooftop installations) and the fiber interconnect length is relatively short, in the order of few hundred meters: in this scenario not only is the fiber an abundant resource: it is often considered a *consumable* (patch-cords) part of a site cabling solution. Duplex fiber short reach pluggables, which are very cost-effective, can be used.

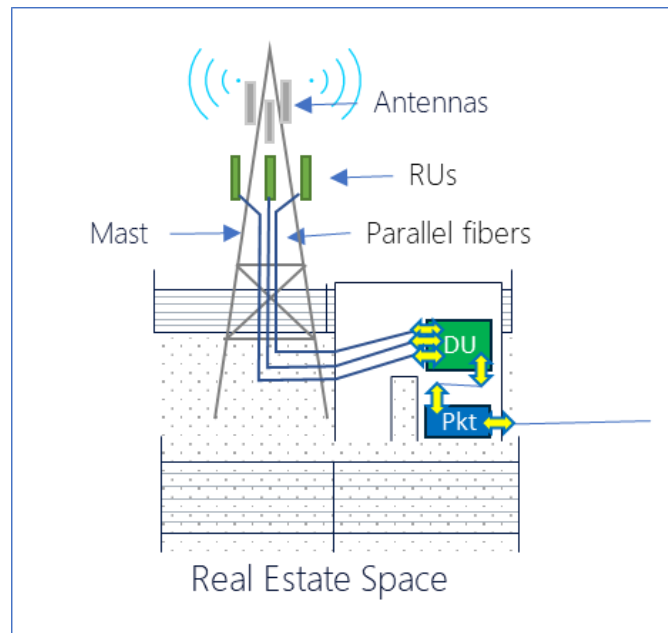

Figure 11: Cell site illustration for the DRAN fiber abundance case.

There are other cases in which the DUs (or DU+CU) and the RUs are not co-located due to for example real estate constraints⁸. In these cases, optical patch-cords cannot be used, and dark fiber (typically part of a large cable running in an underground duct) must be used instead. In this case, it

⁸ One common example is when the DUs are located in the basement of a building and the RUs on the rooftop of another building, one or more blocks away.

may be beneficial to deploy single-fiber BiDi pluggables, allowing to use/lease a single dark fiber strand instead of two.

For DRAN deployments, considering the short distance, it is relatively uncommon to find scenarios with a lack of fiber resources.

10 km is traditionally considered the *shortest distance of interest* for transport networks. However, as is evident from Figure 10, the fiber distances in DRAN deployments are typically much shorter. Reducing the reach requirements may allow to reduce costs by using inherently cheaper laser sources. This happened for instance with Fabry-Pérot (FP) lasers, creating in LLS the typical “up to 2 km” solution space also seen in ITU-T specs for intra-office and IEEE802.3 for data center interconnects.

Scenarios requiring 10G BiDi are currently covered with 15 km-capable lasers due to the lack of suitable Fabry-Pérot lasers with the proper wavelengths (B2: 1270 nm, 1330 nm). Reach-reduced BiDi pluggables at 25 Gb/s can be achieved by reusing the DFB laser with the proper wavelengths (B2: 1270 nm, 1330 nm), currently in use for 15 km 10 Gb/s BiDi. This is an example of trading fiber reach for extra penalties introduced by the higher speed modulation.

7.2. DRAN Optical Blueprints

7.2.1. 2 km RU-DU direct parallel fibers, dual and BiDi fiber Blueprint

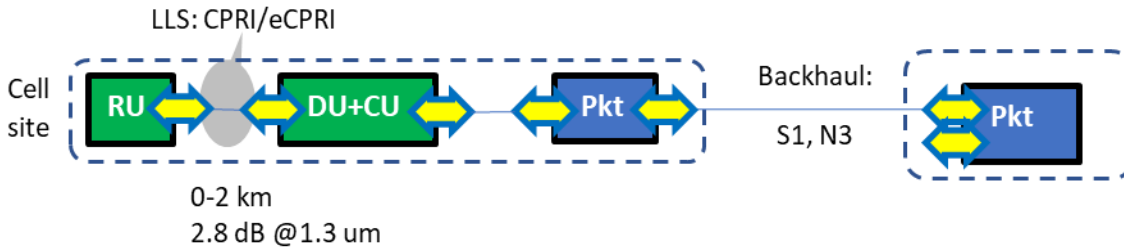

Figure 12: 2 km RU-DU direct parallel fibers Blueprint.

2 km RU-DU Direct parallel fibers Blueprint			
Typical UC	DRAN DU to RU; DU to cell site router intra-site; DU and/or cell site router to microwave element intra-site. Up to 2 km		
Distance	Typ Min 0 km; Typ. Max: 2 km		
Channel IL	2.8 dB @1.3 um (For Typical Max Distance)		
Mode, Nr ch., WL	Dual fiber: O-band 1310 nm. BiDi O-band 1270nm/1330 nm.		
Temp. Range/Class	I-temp		
Lifespan	15 years		
Data rates	10 Gb/s	25 Gb/s	50 Gb/s
Formfactor	SFP+	SFP28	SFP56
FEC, Mod. format	No, NRZ	Yes, NRZ	Yes, PAM4
Power Class	PC2 (1.5 W)	PC2 (1.5 W)	PC2 (1.5 W)
Pluggables codes	10G-2km-O-G-1-2-SFP+ 10G-2km-O-B2-2-1-SFP+	25G-2km-O-G-1-2-SFP28 25G-2km-O-B2-2-1-SFP28	50G-2km-O-G-1-2-SFP56 50G-2km-O-B2-2-1-SFP56
Key technologies	-	Low-cost 25G DFB (e.g., reuse 10G 10 km). New low-cost tech like 25G FP.	TBD
Standards	IEEE 802.3, Clauses 52 & 158 ITU-T G.9806 (Amend 2) See Appendix A Tables 1,2,3	IEEE 802.3, Clauses 114 & 159 ITU-T G.9806 (Amend 2) See Appendix A Tables 1,2,3	IEEE 802.3, Clauses 139 & 160 ITU-T G.9806 (Amend 2) See Appendix A Tables 1,2,3
Market status and outlook (*)	Mature	Mature	Introduced

Table 6: 2 km RU-DU direct parallel fibers Blueprint. Following Figure 10, distances up to 2 km are expected to cover a large majority of the deployments.

7.2.2. 10 km RU-DU direct parallel fibers, dual and BiDi fiber Blueprint

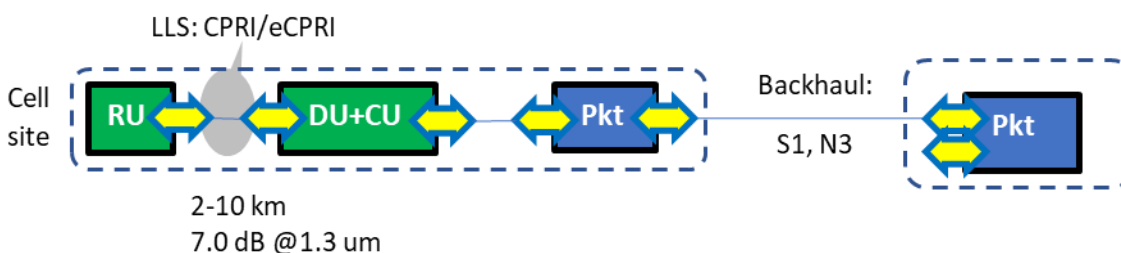

Figure 13: 10 km RU-DU direct parallel fibers Blueprint.

10 km RU DU Direct parallel fibers Blueprint			
Typical UC	DRAN DU to RU. 2-10 km		
Distance	Typ Min 2 km; Typ. Max: 10 km		
Channel IL	7.0 dB @1.3 um (For Typ. Max Distance)		
Mode, Nr ch., WL	Dual fiber: O-band 1310 nm. BiDi O-band 1270nm/1330 nm.		
Temp. Range/Class	I-temp		
Lifespan	15 years		
Data rates	10 Gb/s	25 Gb/s	50 Gb/s
Formfactor	SFP+	SFP28	SFP56
FEC, Mod format	No, NRZ	Yes, NRZ	Yes, PAM4
Power Class	PC2 (1.5 W)	PC2 (1.5 W)	PC2 (1.5 W)
Pluggables codes	10G-10km-O-G-1-2-SFP+ 10G-10km-O-B2-2-1-SFP+	25G-10km-O-G-1-2-SFP28 25G-10km-O-B2-2-1-SFP28	50G-10km-O-G-1-2-SFP56 50G-10km-O-B2-2-1-SFP56
Key technologies	-	Low-cost 25G DFB	TBD
Standards	IEEE 802.3, Clauses 52 & 158 ITU-T G.9806 (Amend 2) See Appendix A Tables 5,6,7	IEEE 802.3, Clause 114 & 159 ITU-T G.9806 (Amend 2) See Appendix A Tables 5,6,7	IEEE 802.3, Clauses 139 & 160 ITU-T G.9806 (Amend 2) See Appendix A Tables 5,6,7
Market status and outlook	Mature	Mature	Introduced

Table 7: 10 km RU-DU direct parallel fibers Blueprint. (*) For DRAN, distances between 2 and 10 km are expected to be much fewer than those ≤ 2 km.

8. Mobile Optical Solution Blueprints for LLS in Centralized RAN (CRAN)

8.1. Overview

Centralization of DUs to a single common location drives the need to cover longer fiber distances to connect with the RUs: typical values span for a few kilometers up to 20 km. Specifically, the majority of cases will be below 10 km, almost all below 15 km, and very few cases up to 20 km.

Figure 12 depicts the centralization of the DU and optionally the CU to a hub site. It should be noted that there are three conceivable categories of solutions involving the presence/absence of transport equipment at each end. These are:

1. Active-Active: there is transport equipment at both ends (e.g., Cell site #1)
2. Semi-Active: there is transport equipment only at the hub location. At the cell site, the optical module is plugged directly into the RU (e.g., Cell site #2)
3. Passive-Passive: there is no transport equipment. The optical modules are plugged directly into the RAN equipment at both extremity (e.g., Cell site #3)

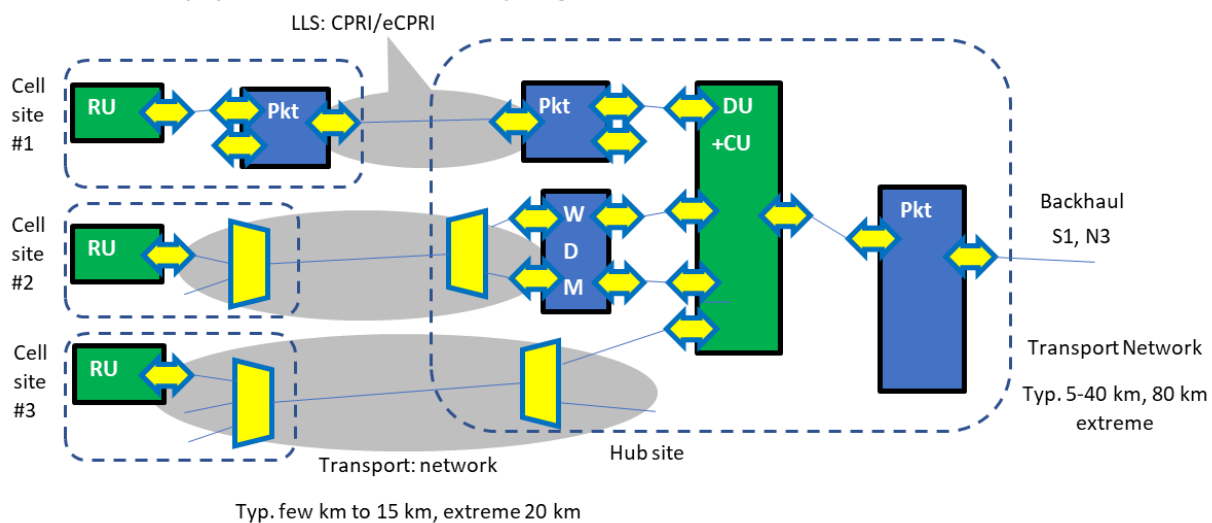

Figure 14: CRAN architecture with RAN nodes, transport nodes and optical pluggables. Cell site #1 shows a case with packet aggregation, Cell site #2 shows a case with semi-active WDM, and Cell site #3 shows a case with passive WDM aggregation.

In CRAN, the site cabling scenario (described for DRAN), which can be solved with optical patch-cords, is clearly not applicable: instead, an installed fiber plant must be used. Availability of fibers varies greatly with the region and the local policies and market regulations.

There are scenarios in which fiber can be considered a relatively abundant resource, for example, in cases where the network operator also owns fiber assets, or because the cost for leasing fiber resources from third parties is relatively low. In other scenarios, typically in dense urban areas and

in unregulated markets, fiber is a scarce resource with high value: its lease costs can be high, driving fiber-lean solutions.

Duplex fiber solutions are used in the fiber abundance cases and when the cost of fiber is low. However, in many cases it is very attractive to use optical BiDi pluggables to reduce the number of fibers by two vs dual fiber pluggables.

Another way to effectively use fiber resources is to use WDM technologies. Comparing the laser cost of an 18-wavelength CWDM system to that of a 48-wavelength DWDM system, both for 10 Gb/s and 15 km reach, comes out to about the same for both systems since they use similar cooled EML transmitters. Thus, the DWDM system is a better choice for scalability reasons. Inherently cheaper, cooled DFB, directly modulated lasers can be used for CWDM, but only for the six wavelengths close to the zero dispersion of fiber (1310 nm). If six wavelengths/ three bidirectional links over a single fiber are enough, CWDM can be a cost-effective alternative. Such cost-effective CWDM solutions can currently offer a reach of about 10 km, so while the sweet spot is 15 km reach, it is not clear whether this technology should be improved in reach as this would potentially lead to higher cost.

There are, conceptually, two flavors of WDM transport, one that uses a wavelength mux as the branching node in the field and one that uses a power splitter in the field [G989].

- WR-WDM: the first is the more prominent solution and is referred to as Wavelength Routed (WR) since the downstream wavelengths are routed by the wavelength mux at the branching node. There are a number of standardization efforts for this generic architecture (e.g., ORAN, ITU-T SG15 Q6 and ITU-T SG15 Q2 [G.989.x] and [G.9802.x])). Blueprints for this option are presented in Sections 8 and 9.
- WS-WDM: the second is being explored by some operators and is referred to as a Wavelength Selected (WS) because the desired downstream wavelength must be selected by the end node from among all the wavelengths arriving at that point. Some standardization work has been done on this architecture by ITU-T SG15 Q2 [G.989.x] but it is not a mainstream solution at this point. The option will be described in section 12 as a solution that is under evaluation for the future.

NOTE: In some circles, the term PON (Passive Optical Network) is used to describe any point to multi-point architecture that involves a passive branching node, whether that is a Wavelength MUX or a Power Splitter. TDM-PON is the most common form of PON but it is not the only type of PON. There can also be TWDM-PON and WDM-PON in which the users share a time slot, a wavelength or a combination of the two. Under this definition, the above two architectures would be referred to as a WR-WDM-PON and a WS-WDM-PON. These terms are commonly used in fiber access circles but not necessarily elsewhere, so this note is for background information.

A final observation should be made regarding the architectures that use WDM. In fact, the branching node (whether Wavelength Mux or Power Splitter) can be located at either the cell site or at some other location in the fiber access outside plant. Both alternatives are possible, even though the illustrations may show one location or the other. The location does not affect the functionality.

Packet aggregation enables using high-speed gray optics to reduce the fiber count. Single fiber BiDi high bit rate interfaces couldn't be designed in a cheap and simple way in the era of 4x25 Gb/s-based 100 Gb/s implementation, but the rise of single lambda 100 Gb/s solutions paved the way for simple BiDi (e.g., 1270 nm/1310 nm) single fiber implementations.

The combination of high bit rates and wavelength division multiplexing provides a route to scale capacity, for cases where it is not possible to meet the requirement on the number of fiber resources with BiDi optics. Coherent pluggables are today not cost-optimized for use in CRAN, but direct-detect alternatives are few and their limited performance is placing more demands on the optical infrastructure: the definition of cost reduction opportunities for coherent pluggables should be addressed by new industrial agreements. The same 100G+ bit rate solutions will of course also be useful to support future further capacity growth in DRAN.

8.2. CRAN Optical Blueprints

8.2.1. 15 km RU – DU direct parallel fibers, dual and BiDi fiber Blueprint

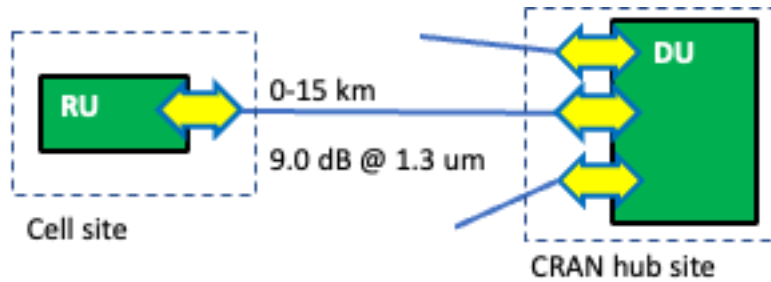

Figure 15: 15 km RU-DU direct parallel fibers Blueprint.

15 km RU DU Direct parallel fibers Blueprint

Typical UC	CRAN DU to RU		
Distance	Typ Min 0 km; Typ. Max: 15 km		
Channel IL	9.0 dB @1.3 um (For Typ. Max Distance)		
Mode, Nr ch., WL	Dual fiber: O-band 1310 nm. BiDi O-band 1270nm/1330 nm.		
Temp. Range/Class	I-temp		
Lifespan	15 years		
Data rates	10 Gb/s	25 Gb/s	50 Gb/s
Formfactor	SFP+	SFP28	SFP56
FEC, Mod. format	No, NRZ	Yes, NRZ	Yes, PAM4
Power Class	PC2 (1.5 W)	PC2 (1.5 W)	PC2 (1.5 W)
Pluggables codes	10G-15km-O-G-1-2-SFP+ 10G-15km-O-B2-2-1-SFP+	25G-15km-O-G-1-2-SFP28 25G-15km-O-B2-2-1-SFP28	50G-15km-O-G-1-2-SFP56 50G-15-B2-2-1-SFP56
Key technologies	-	Low-cost 25G DFB	TBD
Standards	IEEE 802.3, Clause 158 See Appendix A Tables 9,10	IEEE 802.3, Clause 159 See Appendix A Tables 9,10	IEEE 802.3, Clause 160 See Appendix A Tables 9,10
Market status and outlook (*)	Mature	Mature	Introduced

Table 8: 15 km RU-DU direct parallel fibers Blueprint. For CRAN, the fiber abundance case is a medium size market.

8.2.2. 10 km RU - DU, passive CWDM over a single fiber Blueprint

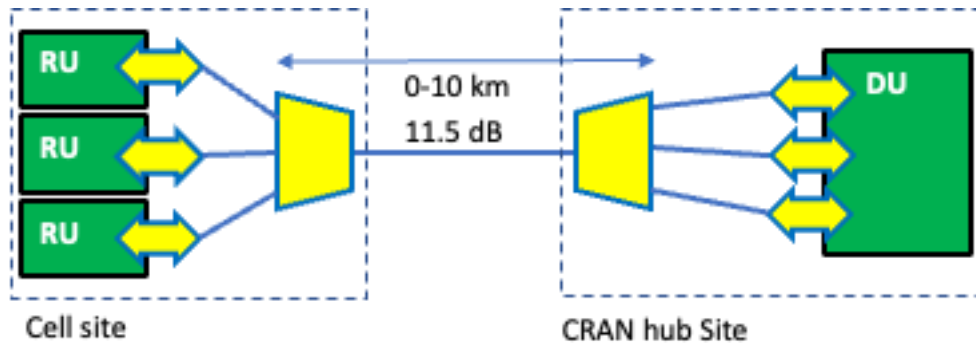

Figure 16: 10 km RU-DU CWDM passive wavelength multiplexed, P2P or P2MP Blueprint.

10 km RU-DU CWDM Blueprint		
Typical UC	CRAN DU to RU. Up to 10 km CWDM P2P or P2MP links up to 3 SFP+ pairs using the same single trunk fiber	
Distance	Typ Min 0 km; Typ. Max: 10 km	
Channel IL	7.0 dB @1310 nm for the fiber (For Typ. Max Dist.), 4.5 dB per WDM mux/demux pair, total 11.5 dB	
Mode, Nr ch., WL	Dual fiber pluggables, single fiber trunk: Wavelength pairs (DU/RU): 1271/1291, 1311/1331, 1351/1371 nm (i.e. the six shortest wavelengths from [G.694.2])	
Temp. Range/Class	I-temp	
Lifespan	15 years	
Data rates	10 Gb/s	25 Gb/s
Formfactor	SFP+	-
FEC. Mod format	No, NRZ	TBD
Power Class	PC3 (2.0 W)	
Pluggables codes	10G-10km-*-C-6-2-SFP+	
Key technologies	-	
Standards	ITU-T G.695. See Appendix A Table 12	-
Market status and outlook (*)	Mature	For 25G, the global market demand is not concluded at this point.

Table 9: 10 km RU-DU CWDM Blueprint. (*) The global market outlook for CWDM is not clear at this point

8.2.3. 15 km RU-DU, passive DWDM over a single fiber Blueprint

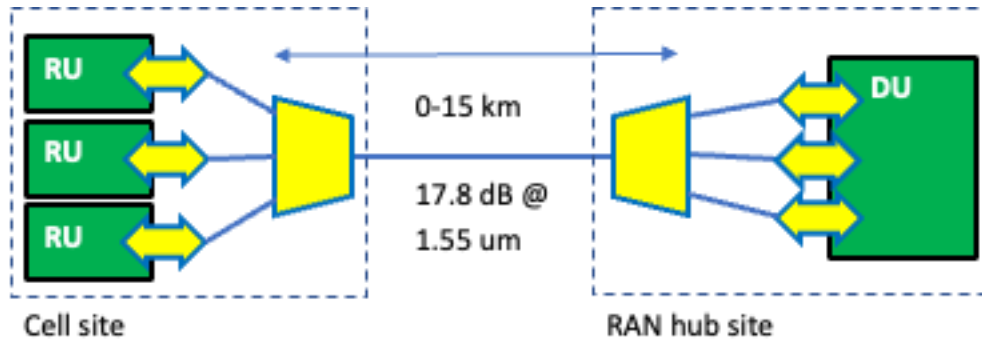

Figure 17: 15 km RU-DU, DWDM passive wavelength multiplexed, P2P or P2MP Blueprint.

15 km RU-DU DWDM Blueprint		
Typical UC	CRAN DU to RU. Up to 15 km DWDM P2P (all RUs at the same location together with the optical multiplexer) or P2MP (the RUs are located in slightly different locations, with the optical multiplexer at one of those, or another location) links up to 24 SFP+ pairs using the same single trunk fiber.	
Distance	Typ Min 0 km; Typ. Max: 15 km	
Channel IL	6.8 dB @1.55 um for the fiber (for Typ. Max Dist.), 5.5 dB per WDM mux, total 17.8 dB	
Chromatic Dispersion	270 ps/nm	
Mode, Nr ch., WL	Dual fiber pluggables, single fiber trunk: 48 wavelengths @ 0.8nm/100GHz spacing	
Temp. Range/Class	I-temp	
Lifespan	15 years	
Data rates	10 Gb/s	25 Gb/s
Formfactor	SFP+	SFP28
FEC, Mod format	No, NRZ	Yes, NRZ
Power Class	PC4 (2.5 W)	PC4 (2.5 W)
Pluggables codes	10G-15km-C-D-48-2-SFP+	25G-15km-C-D-48-2-SFP28
Key technologies	Low-cost EML DWDM, without wavelength lockers. Athermal AWG and TFF filters	
Standards	ITU-T G.698.1, Table 8.3. See Appendix A Table 13	-
Market status and outlook (*)	Mature	Mature

Table 10: 15 km RU-DU DWDM Blueprint. (*) Using DWDM to solve fiber scarcity for CRAN is common. Higher rates are not expected before 2023.

8.2.4. 15 km RU-DU, passive DWDM bus over a single fiber Blueprint

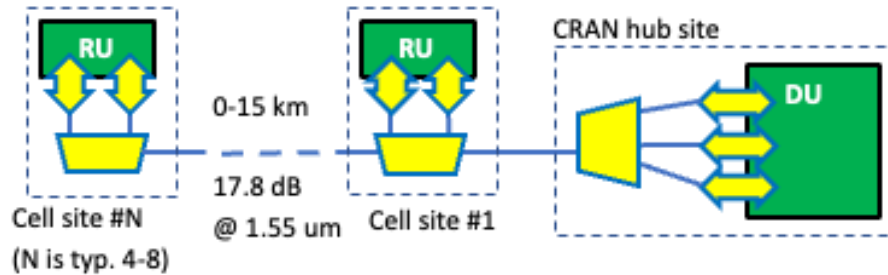

Figure 18: 15 km RU-DU, DWDM passive wavelength multiplexed bus Blueprint.

15 km RU-DU DWDM bus Blueprint		
Typical UC	CRAN DU to radio unit (RU). Up to 15 km DWDM bus or horseshoe topologies with one headend at DU side and multiple add/drop RU sites. Links up to 24 SFP+ pairs using the same single trunk fiber. <ul style="list-style-type: none"> - Flexible use of the available loss budget up to 17.8 dB. (*) - Max number of added/dropped channel at each OADM: 6 - Number of OADMs : Up to 8. (**) 	
Distance	Typ Min 0 km; Typ. Max: 15 km	
Channel IL	Max 17.8 dB to use for the fiber (max 6.8 dB @1.55 um), 0.6 dB per OADM pass and 3.0 dB for add/drop (up to 8 OADMs (**)).	
Chromatic Dispersion	270 ps/nm	
Mode, Nr ch., WL	Dual fiber pluggables, single fiber trunk between MUX and OADM: 48 wavelengths @ 0.8nm/100GHz spacing.	
Temp. Range/Class	I-temp	
Lifespan	15 years	
Data rates	10 Gb/s	25 Gb/s
Formfactor	SFP+	SFP28
FEC	No	Yes
Power Class	PC4 (2.5 W)	PC4 (2.5 W)
Pluggables codes	10G-15km-C-D-48-2-SFP+	25G-15km-C-D-48-2-SFP28
Key technologies	Low-cost EML DWDM, without wavelength lockers. Athermal AWG and OADM TFF filters.	
Standards	ITU-T G.698.1, Table 8.3. See Appendix A Table 13	-
Market status and outlook (***)	Mature	Mature

Table 11: 15 km RU-DU DWDM bus Blueprint. (*) The 17.8 dB value comes from the 8.2.3 Blueprint. Flexible use means that the total loss budget is not calculated as a sum of the fiber and filters losses, but specified as a system limit, that a system design can use a combination of fiber and filter losses up to that value. (**) Typical no. of OADMs are 4-6, with cases of 7-8 are expected to be few. (***) Using DWDM to solve fiber scarcity for CRAN is common. Higher rates are not expected before 2023.

8.2.5. 15 km RU-DU, semi-active DWDM over a single fiber Blueprint

This Blueprint is a combination of Blueprints 8.2.3 for the DWDM part, and 7.2.1 for the WDM node to DU optics. In addition to those use cases, this Blueprint offers a WDM demarcation node.

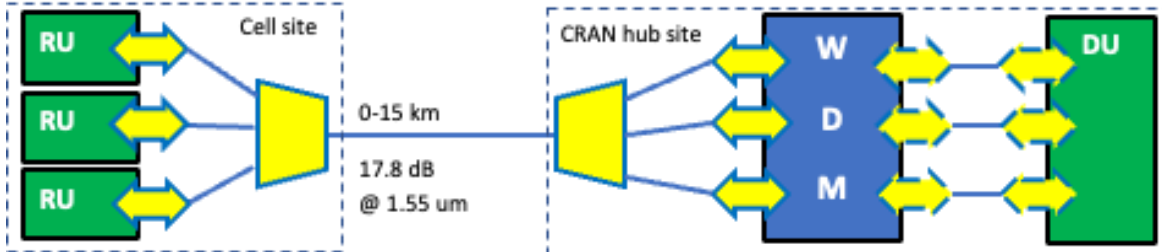

Figure 19: 15 km RU-DU semi-active wavelength multiplexed, P2P or P2MP Blueprint. The intraoffice pluggables at the hub site may be C-temp as indicated by dashed borders.

15 km RU-DU semi-active DWDM Blueprint

Typical UC	CRAN DU to RU. Up to 15 km DWDM P2P (all RUs at the same location together with the optical multiplexer) or P2MP (the RUs are located in slightly different locations, with the optical multiplexer at one of those, or another location) links up to 24 SFP+ pairs using the same single trunk fiber.	
Distance	Typ Min 0 km; Typ. Max: 15 km	
Channel IL	6.8 dB @1.55 um for the fiber (for Typ. Max Dist.), 5.5 dB per WDM mux, total 17.8 dB	
Chromatic Dispersion	270 ps/nm	
Mode, Nr ch., WL	Dual fiber pluggables, single fiber trunk: 48 wavelengths @ 0.8nm/100GHz spacing	
Temp. Range/Class	I-temp	
Lifespan	15 years	
Data rates	10 Gb/s	25 Gb/s
Formfactor	SFP+	SFP28
FEC, Mod format	No, NRZ	Yes, NRZ
Power Class	PC4 (2.5 W)	PC4 (2.5 W)
Pluggables codes	10G-15km-C-D-48-2-SFP+	25G-15km-C-D-48-2-SFP28
Key technologies	Low-cost EML DWDM, without wavelength lockers. Athermal AWG and TFF filters	
Standards	ITU-T G.698.1, Table 8.3. See Appendix A Table 13	-
Market status and outlook (*)	Mature	Mature

Table 12: 15 km RU-DU semi-active DWDM Blueprint. This is the same table as used for blueprint 8.2.3 for the DWDM part. (*) Using DWDM to solve fiber scarcity for CRAN is common. Higher rates are not expected before 2023.

8.2.6. 2 km RU-DU packet multiplexing, dual or BiDi fiber Blueprint

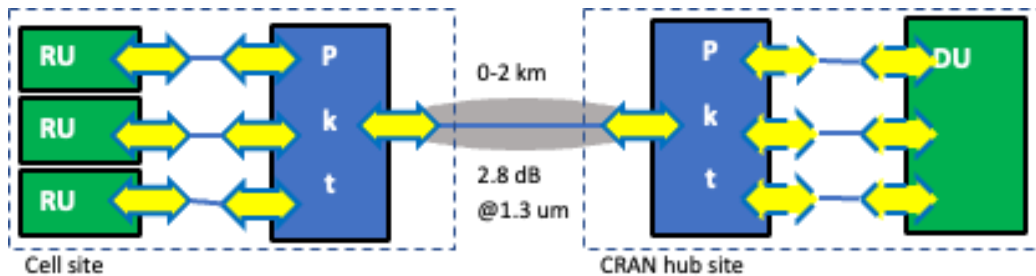

Figure 20 : 2 km RU-DU, packet multiplexing, P2P or P2MP Blueprint. The link specified has a gray background. There may be additional intermediate Pkt nodes between the depicted Pkt node and DU, for example on case of cloud RAN deployments at the hub site. The intraoffice pluggables at the hub site may be C-temp as indicated by dashed borders.

2 km RU-DU packet multiplexing Blueprint		
Typical UC	DU to RU via packet-multiplexed interconnect, up to 2 km BiDi fiber between packet nodes. P2P (all RUs at the same location together with the optical multiplexer) or P2MP (the RUs in slightly different locations, with the packet multiplexer at one of those, or another location). Short reach 10G/25G optical links (<2km, see Blueprint 7.2.1) or direct attach copper cables (DAC) between Pkt node and the corresponding DU/RU.	
Distance	Typ Min 0 km; Typ. Max: 2 km	
Channel IL	2.8 dB @1.3 um (For Typ. Max Distance)	
Mode, Nr ch., WL	Dual fiber: O-band 1310 nm. BiDi O-band 1270nm/1330 nm.	
Temp. Range/Class	I-temp	
Lifespan	15 years	
Data rates	25 Gb/s	100 Gb/s
Formfactor	SFP28	QSFP28
FEC, Mod. format	No, NRZ	Yes, PAM4 or NRZ for 4WDM
Power Class	PC4 (2.5 W)	PC4 (3.5 W)
Pluggables codes	25G-2km-O-G-1-2-SFP28 25G-2km-O-B2-2-1-SFP28	100G-2km-O-G-1-2-QSFP28 or 100G-2km-O-C/L-4-2-QSFP28 100G-2km-O-B2-2-1-QSFP28
Key Technologies	-	Low-cost integrated 4x25G WDM or single lambda 100G Tx and Rx. BiDi: 1270nm/1330nm BOSA with single lambda 100G.
Standards	IEEE 802.3, Clauses 114 & 159, ITU-T G.9806 (Amend 2) See Appendix A Tables 1,2,3	IEEE 802.3, Clause 140 or CWDM4 MSA, ITU-T G.9806 (Amend 3) See Appendix A Table 4
Market status and outlook (*)	Mature	Dual fiber 100G 4WDM-10 mature for mobile transport; single lambda 100G ramping

Table 13: 2 km RU-DU packet multiplexing Blueprint. (*) Higher rates (400G) are not expected before 2023.

8.2.7. 15 km RU-DU packet multiplexing, dual or BiDi fiber Blueprint

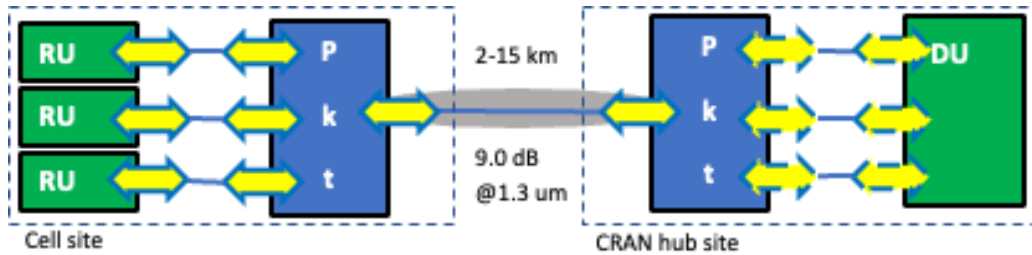

Figure 21: 15 km RU-DU packet multiplexed, P2P or P2MP Blueprint. The link specified has a gray background. There may be additional intermediate Pkt nodes between the depicted Pkt node and DU, for example on case of cloud RAN deployments at the hub site. The intraoffice pluggable at the hub site may be C-temp as indicated by dashed borders.

15 km RU DU packet multiplexed links Blueprint

Typical UC	DU to RU via packet-multiplexed interconnect, 2-15 km BiDi fiber between packet nodes. P2P (all RUs at the same location together with the optical multiplexer) or P2MP (the RUs in slightly different locations, with the packet multiplexer at one of those, or another location). Short reach 10G/25G optical links (<2 km, see Blueprint 7.2.1) or direct attach copper cables (DAC) between Pkt node and the corresponding DU/RU.	
Distance	Typ Min 0 km; Typ. Max: 15 km (*)	
Channel IL	9.0 dB @ 1.3 um (For Typ. Max Distance)	
Mode, Nr ch., WL	Dual fiber: O-band 1310 nm. BiDi O-band 1270 nm/1330 nm.	
Temp. Range/Class	I-temp	
Lifespan	15 years	
Data rates	25 Gb/s	100 Gb/s
Formfactor	SFP28	QSFP28
FEC, Mod. format	Yes, NRZ	Yes, PAM4 or NRZ for 4WDM
Power Class	PC4 (2.5 W)	PC4 (3.5 W)
Pluggables codes	25G-15 km-O-G-1-2-SFP28 25G-15 km-O-B2-2-1-SFP28	100G-15 km-O-G-1-2-QSFP28 or 100G-15 km-O-L-4-2-QSFP28 100G-15 km-O-B2-2-1-QSFP28
Key Technologies	-	Low-cost integrated 4x25G WDM or single lambda 100G Tx and Rx. BiDi: 1270 nm/1330 nm BOSA with single lambda 100G.
Standards	IEEE 802.3, Clause 159. See Appendix A Tables 9.10	100G Lambda MSA or 100G-4WDM-20 MSA, ITU-T G.9806 (Amend 3). See Appendix A Table 11
Market status and outlook (**)	Mature	Dual fiber 100G 4WDM-20 mature for mobile transport; single lambda 100G emerging.

Table 14: 15 km RU-DU packet multiplexing Blueprint. (*) For 100G, 10 km is more cost-effective at this point, while 15 km is the desirable reach for all CRAN LLS deployment cases. (**) Higher rates (400G) are not expected before 2023.

9. Mobile Optical Solution Blueprints for Backhaul and HLS

9.1. Overview

The mobile backhaul transport network connects the RAN segment with the mobile core segment and has a tiered hierarchical packet aggregation architecture [GSTR-TN5G]. The mobile HLS transport network connects the DUs and the CUs within the RAN. In both cases, the requirements on the transport traffic in terms of latency, delay variance and throughput are less stringent compared with LLS.

The figures below show the overall architectures for backhaul and HLS for DRAN and VRAN, and CRAN. The term *multi-service* is used generically to indicate any type of WDM, packet, TDM, etc., transport network used for different types of services, such as mobile access, enterprise site connectivity, residential connectivity, etc.

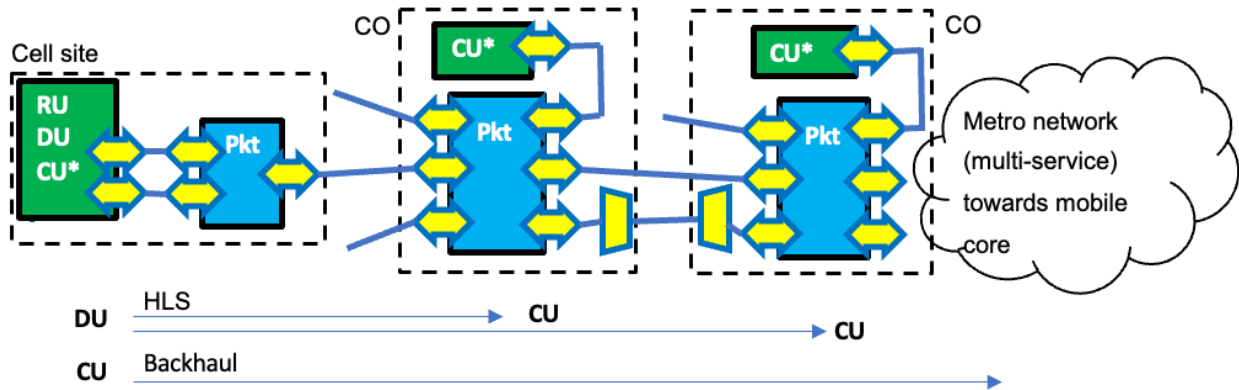

Figure 22: Backhaul and HLS for DRAN and virtual RAN. CU* indicates possible locations for the CU, at the cell site, or at the closest CO. The latter constitutes the VRAN case. The pluggables at the CO sites may be C-temp as indicated by dashed borders for the intraoffice ones.

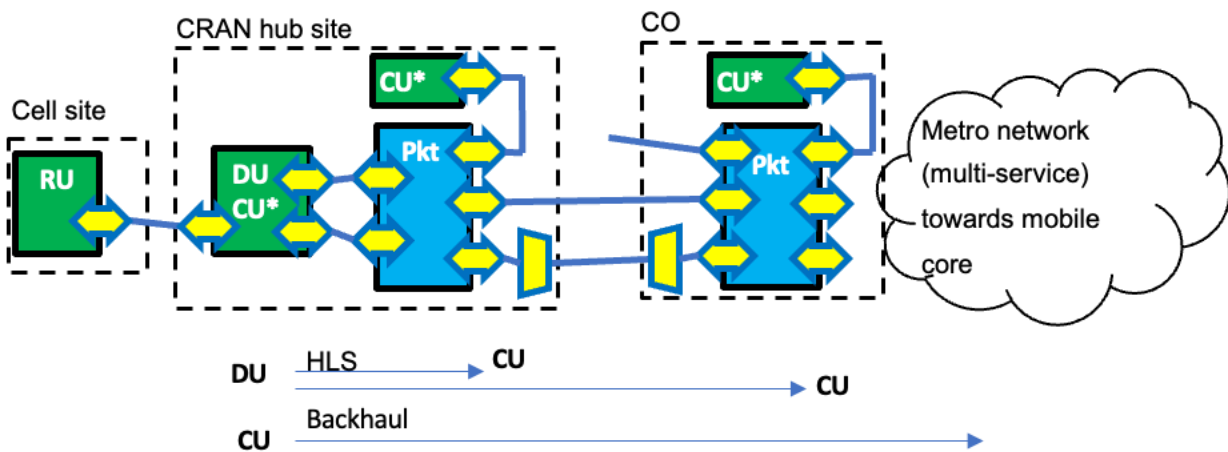

Figure 23: Backhaul and HLS for CRAN. CU* indicates possible locations for the CU, at the CRAN hub site, or at the CO. The latter constitutes the VRAN case. The pluggables at the CRAN hub and CO sites may be C-temp as indicated by dashed borders for the intraoffice ones.

Both DRAN backhaul and CRAN LLS can experience fiber abundance or fiber scarcity in the access part (i.e., between the cell site and the hub site).

When fiber is relatively abundant, it allows for point-to-point parallel fiber links to the individual cell sites, possibly with duplex or BiDi fiber solutions. In scenarios where fiber is more scarce, cost-effective solutions like WDM and TDM-PONs are attractive. TDM-PONs are based on bidirectional use of a common single feeder fiber which is then shared between multiple cell sites by a passive splitter and individual but shorter drop fibers. A single optic in the OLT is shared over multiple ONUs in the cell sites. More information about TDM-PONs and the different standards can be found in [TDM-PON].

In this backhaul access network segment, sometimes also called *Lo-RAN*, located between the cell site packet node and the first level of aggregation, 10 Gb/s 10 km links are typical with 25 Gb/s needed in some places in the near-medium term.

In the backhaul aggregation segment, sometimes also called *Hi-RAN*, which also applies to CRAN backhaul, 100 Gb/s links are typical with distances ranging from 10 km to 40 km, with a non-negligible minority of links demanding even longer reach and different scenarios of fiber resources availability. Traffic increase predictions suggest 400 Gb/s solutions could be needed in the near future. At this point, unamplified DWDM links at 25G per channel are challenging to make cost-effectively beyond 15 km. However, as the technology evolves, there's a need for up to 40 km links as stated above.

Except for the packet nodes at cell sites, other packet equipment is hosted in a temperature-controlled indoor environment, and it is hence possible to use optical pluggables supporting the so-called *C-temp*, with operating case temperatures in the 0° C to 70° C range.

9.2. Backhaul and HLS Optical Blueprints

9.2.1. 2 km DRAN intraoffice backhaul, direct parallel fibers, dual fiber Blueprint

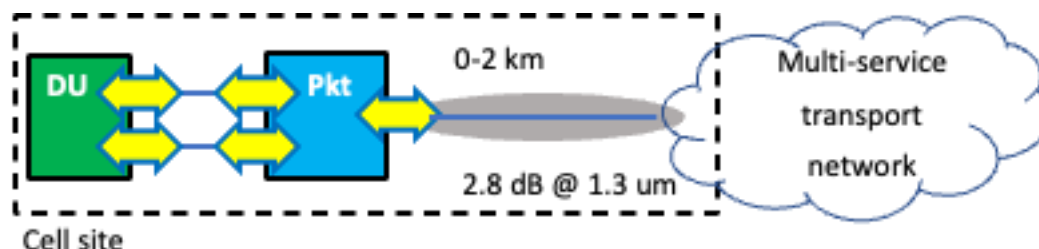

Figure 24: 2 km DRAN intraoffice backhaul direct dual fiber Blueprint. The link specified has a gray background. In cases where the cell site DU is collocated with the CU, backhaul is illustrated. If the CU is located at another location, HLS is illustrated.

2 km intraoffice backhaul Blueprint			
Typical UC	DRAN cell site packet node to leased line service, e.g., AAV with local (i.e., box at cell site) demarcation node, providing the transport to the metro transport network.		
Distance	Typ Min 0 km; Typ. Max: 2 km		
Channel IL	2.8dB @ 1.3 um (For Typ. Max Distance)		
Mode, Nr ch., WL	Dual fiber: O-band 1310 nm		
Temp. Range/Class	I-temp		
Lifespan	15 years		
Data rates	10 Gb/s	25 Gb/s	100 Gb/s
Formfactor	SFP+	SFP28	QSFP28
FEC, Mod. format	No, NRZ	Yes, NRZ	Yes, PAM4 or NRZ for 4WDM
Power Class	PC2 (1.5 W)	PC2 (1.5 W)	PC4 (3.5 W)
Pluggables codes	10G-2km-O-G-1-2-SFP+	25G-2km-O-G-1-2-SFP28	100G-2km-O-G-1-2-QSFP28 or 100G-2km-O-C-4-2-QSFP28
Key technologies	-	Low-cost 25G DFB	Low-cost integrated 4x25G WDM or "single lambda" 100G Tx and Rx.
Standards	IEEE 802.3 CI 52 See Appendix A Table 1	IEEE 802.3 CI 114 See Appendix A Table 1	IEEE 802.3 CI 140 See Appendix A Table 4
Market status and outlook (*)	Mature and relatively common case	Emerging	Emerging

Table 15: 2 km intraoffice backhaul Blueprint. (*) Higher rates (400G) are not expected before 2023.

9.2.2. 10 km DRAN backhaul, direct parallel fibers, dual and BiDi fiber Blueprint

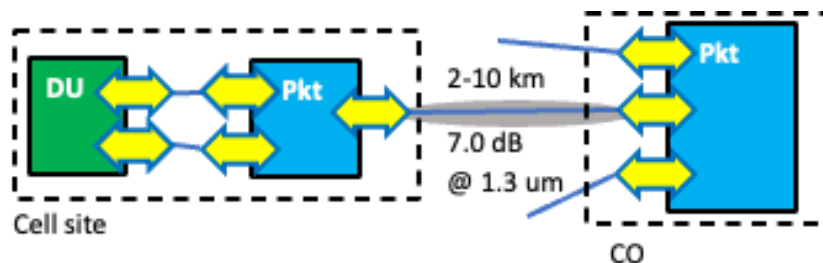

Figure 25: 10 km DRAN backhaul with direct parallel fiber, dual or BiDi Blueprint. The link specified has a gray background. In cases where the cell site DU is collocated with the CU, backhaul is illustrated. If the CU is located at another location, HLS is illustrated.

10 km DRAN backhaul direct parallel fiber Blueprint			
Typical UC	DRAN cell site packet node to CO packet aggregation node.		
Distance	Typ Min 2 km; Typ. Max: 10 km		
Channel IL	7.0 dB @1.3 um (For Typ. Max Dist.)		
Mode, Nr ch., WL	Dual fiber: O-band 1310 nm. BiDi O-band 1270nm/1330 nm.		
Temp. Range/Class	I-temp		
Lifespan	15 years		
Data rates	10 Gb/s	25 Gb/s	100 Gb/s
Formfactor	SFP+	SFP28	QSFP28
FEC, Mod. format	No, NRZ	Yes, NRZ	Yes, PAM4 or NRZ for 4WDM
Power Class	PC2 (1.5 W)	PC2 (1.5 W)	PC4 (3.5 W)
Pluggables codes	10G-10 km-O-G-1-2-SFP+ 10G-10 km-O-B2-2-1-SFP+	25G-10 km-O-G-1-2-SFP28 25G-10 km-O-B2-2-1-SFP28	100G-10 km-O-G-1-2-QSFP28 or 100G-10 km-O-C/L-4-2-QSFP28 100G-10 km-O-B2-2-1-QSFP28
Key technologies	-	Low-cost 25G DFB	Low-cost integrated 4x25G WDM or single lambda 100G Tx and Rx. BiDi: 1270nm/1330nm BOSA with single lambda 100G.
Standards	IEEE 802.3 Cl 52 & 158, G.9806 (Amend 2) See Appendix A Tables 5,6,7	IEEE 802.3 Cl 114 & 159, G.9806 (Amend 2) See Appendix A Tables 5,6,7.	IEEE 802.3 Cl 140 & 88, ITU-T G.9806 (Amend 3) See Appendix A Table 8
Market status and outlook (*)	Mature and relatively common case.	Emerging, complement to 10G.	Few cases but emerging.

Table 16: 10 km DRAN backhaul direct parallel fiber Blueprint. (*) The fiber abundance 10 km case is common for DRAN backhaul.

9.2.3. 40 km DRAN backhaul, direct parallel fibers, dual and BiDi fiber Blueprint

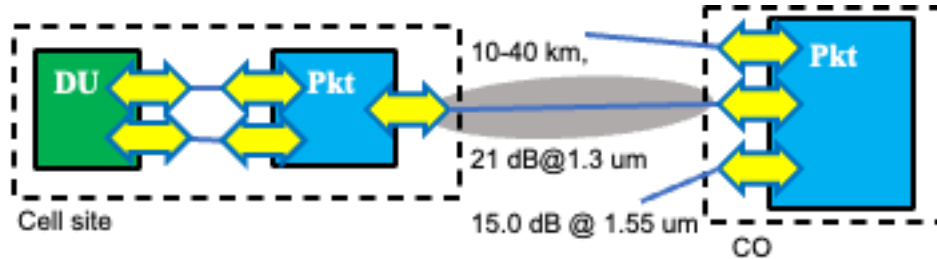

Figure 26: 40 km DRAN backhaul direct parallel fiber, dual or BiDi Blueprint. The link specified has a gray background. In cases where the cell site DU is collocated with the CU, backhaul is illustrated. If the CU is located at another location, HLS is illustrated.

40 km DRAN backhaul direct parallel fiber Blueprint

Typical UC	DRAN cell site packet node to CO packet aggregation node.		
Distance	Typ Min 10 km; Typ. Max: 40 km (*)		
Channel IL	21.0 dB @ 1.3 um (O-band), 15.0 dB @ 1.55 um (For Typ. Max Distance)		
Mode, Nr ch., WL	Dual fiber: for 10G: C-band 1.55 um. For 25G and 100G O-band 1.3 um. BiDi O-band 1270nm/1330 nm.		
Temp. Range/Class	I-temp		
Lifespan	15 years		
Data rates	10 Gb/s	25 Gb/s	100 Gb/s
Formfactor	SFP+	SFP28	QSFP28
FEC, Mod. format	No, NRZ	Yes, NRZ	Yes, PAM4 or NRZ for 4WDM
Power Class	PC4 (2.5 W)	PC4 (2.5 W)	PC4 (3.5 W)
Pluggables codes	10G-40 km-C-G-1-2-SFP+ 10G-40 km-O-B2-2-1-SFP+	25G-40 km-O-G-1-2-SFP28 25G-40 km-O-B2-2-1-SFP28	100G-40 km-O-G-1-2-QSFP28, or 100G-40 km-O-L-4-2-QSFP28
Key technologies	-	Low-cost 25G EML	Low-cost integrated 4x25G WDM or single lambda 100G Tx and Rx. BiDi: 1270nm/1330nm BOSA with single lambda 100G.
Standards	IEEE 802.3 CI 52 & 158 See Appendix A Tables 14,15	IEEE 802.3 CI 114 & 159 See Appendix A Tables 14,15	100G Lambda MSA, IEEE 803.3 CI 88, ITU-T G.9806 (Amend 3). See Appendix A Tables 14,15
Market status and outlook (**)	Mature and relatively common case.	Emerging, complement to 10G.	Few cases but emerging.

Table 17: 40 km DRAN backhaul direct parallel fiber Blueprint. (*) 40 km is challenging for 25G and 100G. (**) The fiber abundance 40 km case is common, but less than 10 km, for DRAN backhaul.

9.2.4. 15 km DRAN backhaul, passive DWDM bus over a single fiber Blueprint

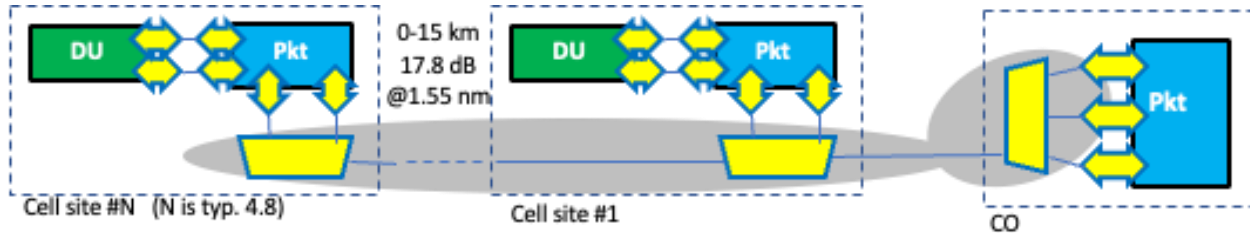

Figure 27: 15 km DRAN backhaul, DWDM passive wavelength multiplexed bus Blueprint. The link specified has a gray background. In cases where the cell site DU is collocated with the CU, backhaul is illustrated. If the CU is located at another location, HLS is illustrated.

15 km DRAN backhaul DWDM bus Blueprint

Typical UC	DRAN cell site packet node to CO packet aggregation. Up to 15 km DWDM bus or horseshoe topologies with headend CO(s) and multiple add/drop cell sites. Links up to 24 SFP+ pairs using the same single trunk fiber.	
	<ul style="list-style-type: none"> - Flexible use of the available loss budget up to 17.8 dB.(*) - Max number of added/dropped channels at each OADM: 6. - Number of OADMs : Up to 8. (**) 	
Distance	Typ Min 0 km; Typ. Max: 15 km	
Channel IL	Max 17.8 dB to use for the fiber (max 6.8 dB @ 1.55 um), 0.6 dB per OADM pass and 3.0 dB for add/drop	
Chromatic Dispersion	270 ps/nm	
Mode, Nr ch., WL	Dual fiber pluggables, single fiber trunk between MUX and OADM: 48 wavelengths @ 0.8 nm/100 GHz	
Temp. Range	I-temp	
Lifespan	15 years	
Data rates	10 Gb/s	25 Gb/s
Formfactor	SFP+	SFP28
FEC, Mod format	No, NRZ	Yes, NRZ
Power Class	PC4 (2.5 W)	PC4 (2.5 W)
Pluggables codes	10G-15 km-C-D-48-2-SFP+	25G-15 km-C-D-48-2-SFP28
Key technologies	Low-cost EML DWDM, without wavelength lockers. Athermal AWG and OADM TFF filters.	
Standards	ITU-T G.698.1 Table 8.3. See Appendix A Table	-
Market status and outlook(***)	Mature.	25G: emerging, complementing 10G over time.

Table 18: 15 km DRAN backhaul DWDM bus Blueprint. (*) Same comments for loss budget and flexible use as Blueprint 8.2.4. (**) Typical no. of OADMs are 4-6, with cases of 7-8 expected to be few. (***) Using DWDM to solve fiber scarcity for backhaul is common. Higher rates are not expected before 2023.

9.2.5. 2 km CRAN intraoffice backhaul, direct parallel fibers, dual fiber Blueprint

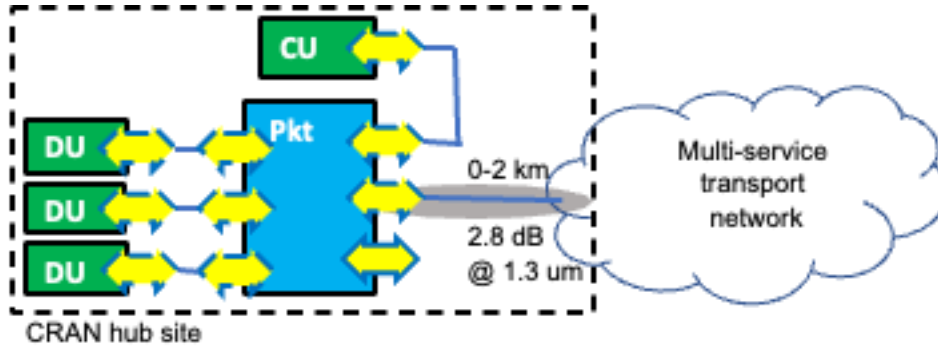

Figure 28: 2 km CRAN hub site intraoffice backhaul direct parallel fiber Blueprint. The link specified has a gray background. In cases where the CU is located at another location, HLS is illustrated. The pluggables at the CRAN hub site may be C-temp as indicated by dashed borders for the intraoffice ones.

2 km intraoffice CRAN hub site intraoffice backhaul Blueprint			
Typical UC	CRAN hub site packet node to leased line service, e.g., AAV, with local (i.e., box at cell site) demarcation node, providing the transport to the metro transport network.		
Distance	Typ Min 0 km; Typ. Max: 2 km		
Channel IL	2.8 dB @ 1.3 um (For Typ. Max Distance)		
Mode, Nr ch., WL	Dual fiber: O-band 1310 nm		
Temp. Range/Class	I-temp (preferred) or C-temp (see section 6.1)		
Lifespan	15 years		
Data rates	10 Gb/s	25 Gb/s	100 Gb/s
Formfactor	SFP+	SFP28	QSFP28
FEC, Mod. format	No, NRZ	Yes, NRZ	Yes, PAM4 or NRZ for 4WDM
Power Class	PC2 (1.5 W)	PC2 (1.5 W)	PC4 (3.5 W)
Pluggables codes	10G-2 km-O-G-1-2-SFP+	25G-2 km-O-G-1-2-SFP28	100G-2 km-O-G-1-2-QSFP28, or 100G-2 km-O-C-4-2-QSFP28
Key technologies	-	Low-cost 25G DFB	Low-cost integrated 4x25G WDM or single lambda 100G Tx and Rx.
Standards	IEEE 802.3 Cl 52 See Appendix A Table 1	IEEE 802.3 Cl 114 See Appendix A Table 1	IEEE 802.3 Cl 140 or CWDM4 MSA See Appendix A Table 4
Market status and outlook (*)	Mature and relatively common case.	Emerging, complement to 10G.	Few cases but emerging.

Table 19: 2 km CRAN hub site intraoffice backhaul Blueprint. (*) Higher rates (400G) are not expected before 2023.

9.2.6. 10 km CRAN backhaul, direct parallel fibers, dual and BiDi fiber Blueprint

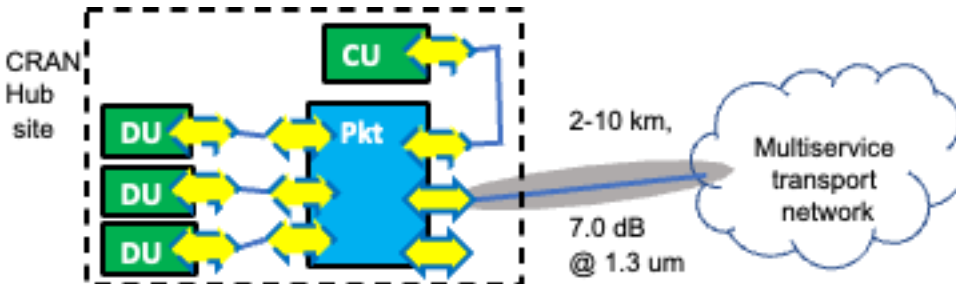

Figure 29: 10 km CRAN backhaul Blueprint (direct P2P, no WDM). The link specified has a gray background. In cases where the CU is located at another location, HLS is illustrated. The pluggables at the CRAN hub site may be C-temp as indicated by dashed borders for the intraoffice ones.

10 km CRAN hub site backhaul direct parallel fiber Blueprint

Typical UC	CRAN hub site Pkt node to Multiservice transport network at another site.		
Distance	Typ Min 2 km; Typ. Max: 10 km		
Channel IL	7.0 dB @ 1.3 um (For Typ. Max Distance)		
Mode, Nr ch., WL	Dual fiber: O-band 1310 nm. BiDi O-band 1270nm/1330 nm.		
Temp. Range/Class	I-temp (preferred) or C-temp (see Section 6.1).		
Lifespan	15 years		
Data rates	10 Gb/s	25 Gb/s	100 Gb/s
Formfactor	SFP+	SFP28	QSFP28
FEC, Mod. format	No, NRZ	Yes, NRZ	Yes, PAM4 or NRZ for 4WDM
Power Class	PC2 (1.5 W)	PC2 (1.5 W)	PC4 (3.5 W)
Pluggables codes	10G-10 km-O-G-1-2-SFP+ 10G-10 km-O-B2-2-1-SFP+	25G-10 km-O-G-1-2-SFP28 25G-10 km-O-B2-2-1-SFP28	100G-10 km-O-G-1-2-QSFP28, or 100G-10 km-O-C/L-4-2-QSFP28 100G-10 km-O-B2-2-1-QSFP28
Key technologies	-	Low-cost 25G DFB	Low-cost integrated 4x25G WDM or single lambda 100G Tx and Rx. BiDi: 1270 nm/1330 nm BOSA with single lambda 100G.
Standards	IEEE 802.3 CI 52 & 158 G.9806 (Amend 2) See Appendix A Tables 5,6,7	IEEE 802.3 CI 114 & 159 G.9806 (Amend 2) See Appendix A Tables 5,6,7	IEEE 802.3 CI 140 & 88, ITU-T G.9806 (Amend 3) See Appendix A Table 8.
Market status and outlook (*)	Mature and relatively common case	Emerging, complement to 10G	Few cases but emerging.

Table 20: 10 km CRAN backhaul direct parallel fiber Blueprint. (*) The fiber abundance 10 km case is common for CRAN backhaul.

9.2.7. 40 km CRAN backhaul, direct parallel fibers, dual and BiDi fiber Blueprint

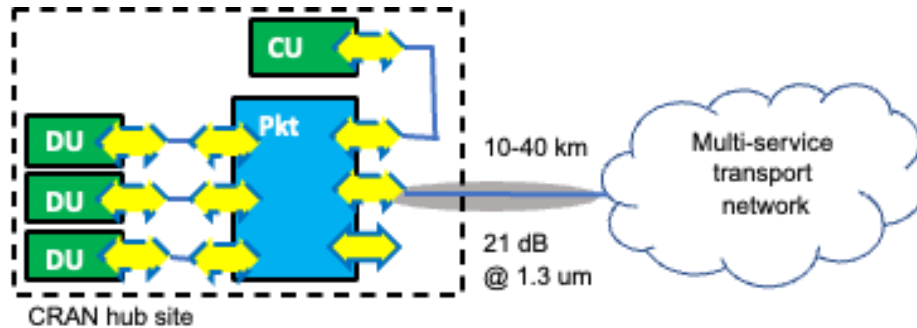

Figure 30: 40 km CRAN hub site backhaul direct parallel fiber Blueprint. The link specified has a gray background. In cases where the CU is located at another location, HLS is illustrated. The pluggables at the CRAN hub site may be C-temp as indicated by dashed borders for the intraoffice ones.

40 km CRAN hub site backhaul direct parallel fiber Blueprint			
Typical UC	CRAN hub site Pkt node to Multiservice transport network at another site.		
Distance	Typ Min 10 km; Typ. Max: 40 km (*)		
Channel IL	21.0 dB @ 1.3 um (O-band), 15.0 dB @1.55 um (For Typ. Max Distance)		
Mode, Nr ch., WL	Dual fiber: For 10G: C-band 1.55 um. For 25G and 100G O-band 1.3 um. BiDi O-band 1270nm/1330 nm.		
Temp. Range/Class	I-temp (preferred) or C-temp (see Section 6.1).		
Lifespan	15 years		
Data rates	10 Gb/s	25 Gb/s	100 Gb/s
Formfactor	SFP+	SFP28	QSFP28
FEC, Mod. format	No, NRZ	Yes, NRZ	Yes, PAM4 or NRZ for 4WDM
Power Class	PC4 (2.5 W)	PC4 (2.5 W)	PC4 (3.5 W)
Pluggables codes	10G-40 km-C-G-1-2-SFP+ 10G-40 km-O-B2-2-1-SFP+	25G-40 km-O-G-1-2-SFP28 25G-40 km-O-B2-2-1-SFP28	100G-40 km-O-G-1-2-QSFP28, 100G-40 km-O-L-4-2-QSFP28 100G-40 km-O-B2-2-1-QSFP28
Key technologies	-	Low-cost 25G EML.	Low-cost integrated 4x25G WDM or single lambda 100G Tx and Rx. BiDi: 1270 nm/1330 nm BOSA with single lambda 100G.
Standards	IEEE 802.3, CI 52 & 158 See Appendix A Tables 14,15	IEEE 802.3 CI 114 & 159 See Appendix A Tables 14,15	100G Lambda MSA, IEEE 803.3 CI 88 ITU-T G.9806 (Amend 3). See Appendix A Tables 14,15
Market status and outlook (**)	Mature and relatively common case.	Emerging, complement to 10G.	Few cases but emerging.

Table 21: 40 km CRAN backhaul direct parallel fiber Blueprint. (*) 40 km is challenging for 25G and 100G. (**) The fiber abundance 40 km case is less common than 10 km for CRAN backhaul.

9.2.8. 15 km CRAN backhaul, passive DWDM over a single trunk fiber Blueprint

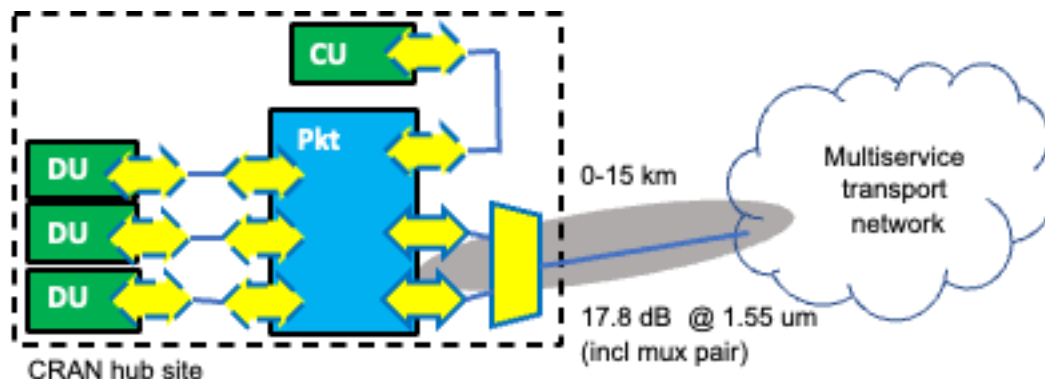

Figure 31: 15 km CRAN backhaul, DWDM passive wavelength multiplexed Blueprint. In cases where the CU is located at another location, HLS is illustrated.

15 km CRAN hub site backhaul DWDM Blueprint		
Typical UC	CRAN hub site Pkt node to Multiservice transport network at another site. Up to 15 km DWDM P2P links with up to 24 SFP+ pairs using the same single trunk fiber.	
Distance	Typ Min 0 km; Typ. Max: 15 km	
Channel IL	6.8 dB @1.55 um for the fiber, 5.5 dB per WDM mux, total 17.8 dB.(For Typ. Max Distance)	
Chromatic Dispersion	270 ps/nm	
Mode, Nr ch., WL	Dual fiber pluggables, single fiber trunk: 48 wavelengths @ 0.8nm/100GHz spacing	
Temp. Range/Class	I-temp (preferred) or C-temp (see Section 6.1)	
Lifespan	15 years	
Data rates	10 Gb/s	25 Gb/s
Formfactor	SFP+	SFP28
FEC, Mod. format	No, NRZ	Yes, NRZ
Power Class	PC4 (2.5 W)	PC4 (2.5 W)
Pluggables codes	10G-15km-C-D-48-2-SFP+	25G-15km-C-D-48-2-SFP28
Key technologies	Low-cost EML DWDM, without wavelength lockers. Athermal AWG and TFF filters.	
Standards	ITU-T G.698.1, Table 8.3. See Appendix A Table 13	-
Market status and outlook (*)	Mature.	25G: emerging, expected to complement 10G over time.

Table 22: 10 km CRAN hub site backhaul DWDM Blueprint. (*) Intra-office or direct fiber cases are expected to be more common. Higher rates are not expected before 2023.

9.2.9. 20 km DRAN Backhaul and HLS with TDM-PON, Separate ONU box Blueprint

A PON system consists of OLT and multiple subtended ONUs. The ONU functionality at the cell site can be provided as a separate ONU box as shown in this Blueprint.

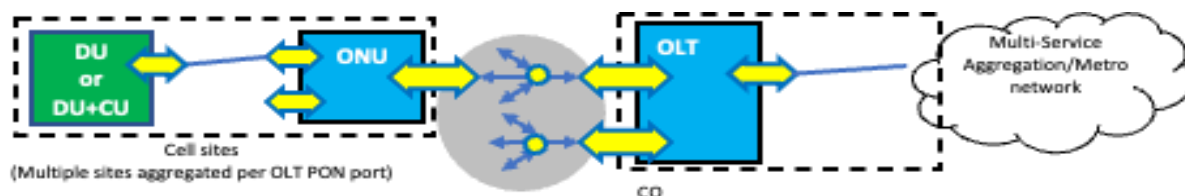

Figure 32: Up to 20 km Backhaul and HLS with TDM-PON using separate ONU box. HLS is depicted in cases where the CU is centralized. Backhaul is depicted in cases where the CU is located at the cell site.

20 km DRAN Backhaul and HLS with TDM-PON, Separate ONU box Blueprint			
Typical UC	Transport from small/medium cell site with DU and optionally CU to the multiservice transport network at another site. The separate ONU box can act as a demarcation point, and as an aggregating point at the cell site when having multiple interfaces. For cases where there is available space for an external transport box at the cell site.		
Distance	Typ. Max: 20 km		
Transmission mode	Single fiber (BiDi)		
Temp. Range/Class	I-temp		
Lifespan	15 years		
Data rates Down / Up	GPON: 2.5 / 1.25 Gb/s	XGS-PON, 10G EPON: 10 / 10 Gb/s	25GS-PON, 25G EPON: 25 / 10 (or 25) Gb/s
Channel IL	B+ (28 dB), C+ (32 dB), C++ (34 dB). Highest Class: D (35 dB).	N1 (29 dB) and N2 (31 dB). Higher classes: E1 (33 dB), E2 (35 dB).	Starting at N1 (29 dB). Higher classes (N2, E1, E2) for longer term.
Wavelength bands	1300-1320 nm Up 1480-1500 nm Down	1260-1280 nm Up 1575-1580 nm Down	Multiple options in the O-band depending on coexistence requirements.
Formfactor	SFP, SFP-DD for dual OLT module	SFP+	SFP28
FEC	Yes	Yes	Yes
Power Class	Dual OLT module: PC4 (2.5 W) Single OLT module: PC2 (1.5 W) ONU module: PC2 (1.5 W)	OLT module: PC4 (2.5 W) ONU module: PC3 (2 W)	OLT module: PC4 (2.5 W) ONU module: PC4 (2.5 W), evolution to PC3 (2 W) is desired.
Pluggables codes	GPON-20 km-OS-B3-1-SFP-OLT GPON-20 km-OS-B3-1-SFP-ONU	XGS-PON-20 km-OL-B3-1-SFP+-OLT XGS-PON-20 km-OL-B3-1-SFP+-ONU	25GS-PON-20 km-O-B3-1-SFP28-OLT 25GS-PON-20 km-O-B3-1-SFP28-ONU
Key technologies	BOSA with DML and PIN or APD.	BOSA with EML and APD.	BOSA with EML and APD.
Standards (Phy & MAC)	ITU-T G.984.x See Appendix A Table 16	IEEE 802.3 Cl. 75. ITU-T G.9807.x See Appendix A Table 16	IEEE 802.3 Cl 141. 25GS-PON MSA See Appendix A Table 16
Market status and outlook	Mature, mass deployment, common case for FTTx, backhaul.	Mature, dominating in more recent deployments, new cases for x-haul.	Emerging technology, future deployment.

Table 23: 20 km DRAN Backhaul and HLS with TDM-PON, Separate ONU box Blueprint. (Note: There are also SFP family-based OLT modules combining both XGS-PON and GPON in a single fiber.)

9.2.10. 20 km DRAN Backhaul and HLS with TDM-PON, Pluggable ONU

Instead of an external box, the cell site ONU functionality can be integrated into the pluggable optic (*Pluggable ONU*, also known as *ONU on a stick* or *Integrated ONU* (iONU)).



Figure 33: Up to 20 km backhaul and HLS with TDM-PON using pluggable ONU. HLS is depicted in cases where the CU is centralized. Backhaul is depicted in cases where the CU is located at cell site.

20 km DRAN Backhaul and HLS with TDM-PON, Pluggable ONU Blueprint			
Typical UC	Transport from small or medium cell site with DU and optionally CU functionality to multiservice transport network at another site. Preferred solution if there is no space for external transport box at cell site.		
Distance	Typ. Max: 20 km		
Transmission mode	Single fiber (BiDi)		
Temp. Range/Class	I-temp		
Lifespan	15 years		
Data rates Down / Up	GPON: 2.5 / 1.25 Gb/s	XGS-PON, 10G EPON: 10 / 10 Gb/s	25GS-PON, 25G EPON: 25 / 10 (or 25) Gb/s
Channel IL	B+ (28 dB), C+ (32 dB), C++ (34 dB). Highest Class D (35 dB)	N1 (29 dB) and N2 (31 dB). High classes E1 (33 dB) and E2 (35 dB)	Starting at N1 (29 dB). Higher classes (N2, E1, E2) for longer term.
Wavelength bands	1300-1320 nm Up 1480-1500 nm Down	1260-1280 nm Up 1575-1580 nm Down	Multiple waveband options in the O-band depending on coexistence requirements.
Formfactor	SFP, SFP-DD for dual OLT module	SFP+	SFP28
FEC	Yes	Yes	Yes
Power Class	Dual OLT module: PC4 (2.5 W) Single OLT module: PC2 (1.5 W) integrated ONU module: PC3 (2 W)	OLT module: PC4 (2.5 W) Integrated ONU module: PC4 (2.5 W), evolution to PC3 (2 W) is desired	OLT module: PC4 (2.5 W) Integrated ONU module: TBD.
Pluggables codes	GPON-20 km-OS-B3-1-SFP-OLT GPON-20 km-OS-B3-1-SFP-iONU	XGS-PON-20 km-OL-B3-1-SFP+-OLT	25GS-PON-20 km-O-B3-1-SFP28-OLT 25GS-PON-20 km-O-B3-1-SFP28-iONU
Key technologies	BOSA w. DML and PIN or APD. Pluggable also contains SoC for ONU PON MAC.	BOSA with EML and APD. Pluggable also contains SoC for ONU PON MAC.	BOSA with EML and APD. Pluggable also contains SoC for ONU PON MAC.
Standards (Phy & MAC)	ITU-T G.984.x See Appendix A Table 16	IEEE 802.3 Cl. 75, ITU-T G.9807.x See Appendix A Table 16	IEEE 802.3 Cl 141, 25GS-PON MSA See Appendix Table 16
Market status and outlook	GPON is mature, established mass deployment, common case for FTTx and backhaul.	XGS-PON is mature, used in recent deployments, new cases for x-haul. Pluggable ONU is emerging.	Emerging technology, future deployment.

Table 24 : 20 km DRAN Backhaul and HLS with TDM-PON, Pluggable ONU Blueprint. (Note: There are also SFP family-based OLT modules combining both XGS-PON and GPON in a single fiber.)

10. Summary of Optical Pluggables vs. Blueprint

The tables below summarize the pluggable variants used by the different Blueprints described in the paper. It should be noted that the tables in this section include all the pluggables used in the Blueprint illustrations, not only the ones highlighted and covered by the individual Blueprint tables, for example dual fiber 10G and 25G pluggables used to connect equipment within the same site.

The following codes are used for the 2nd row in the tables below:

- x: a pluggable that is the same at both ends
- y: a pluggable that is only at the network side (closer to mobile core network)
- z: a pluggable that is only at the access side (closer to the RU)

If the module type is the same at both ends, it gets an x in the table. If there are two module types, one for each end, there is both a y and a z in the table entry.

Pluggables vs Blueprints	10G-2 km-O-G-1-2-SFP+	10G-10 km-O-G-1-2-SFP+	10G-15 km-O-G-1-2-SFP+	10G-40 km-C-G-1-2-SFP+	25G-2 km-O-G-1-2-SFP28	25G-10 km-O-G-1-2-SFP28	25G-15 km-O-G-1-2-SFP28	25G-40 km-O-G-1-2-SFP28	50G-2 km-O-G-1-2-SFP28	50G-10 km-O-G-1-2-SFP28	50G-15 km-O-G-1-2-SFP28	100G-2 km-O-G-1-2-QSFP28 *	100G-10 km-O-G-1-2-QSFP28 *	100G-15 km-O-G-1-2-QSFP28 *	100G-40 km-O-G-1-2-QSFP28 *
7.2.1	x	x	x	x	x	x	x	x	x	x	x	x	x	x	x
7.2.2	o				o				o						
8.2.1		o				o				o					
8.2.5	o					o					o				
8.2.6	o				o							o			
8.2.7	o				o		o							o	
9.2.1	o				o							o			
9.2.2	o	o			o	o							o		
9.2.3	o			o	o			o							o
9.2.4	o				o										
9.2.5	o				o							o			
9.2.6	o	o			o	o							o		
9.2.7	o			o	o			o							o
9.2.8	o				o										

Table 25: Summary of dual fiber client (only one pluggable pair using each fiber) pluggables needed for each Blueprint. (* The 100G dual fiber pluggables may also be 4x25G, e.g., 100G-40km-O-L-4-2-QSFP28)

Pluggables vs Blueprints	10G-2 km-O-B2-2-1-SFP+	10G-10 km-O-B2-2-1-SFP+	10G-15 km-O-B2-2-1-SFP+	10G-40 km-O-B2-2-1-SFP+	25G-2 km-O-B2-2-1-SFP28	25G-10 km-O-B2-2-1-SFP28	25G-15 km-O-B2-2-1-SFP28	25G-40 km-O-B2-2-1-SFP28	50G-2 km-O-B2-2-1-SFP28	50G-10 km-O-B2-2-1-SFP28	50G-15 km-O-B2-2-1-SFP28	100G-2 km-O-B2-2-1-QSFP28	100G-10 km-O-B2-2-1-QSFP28	100G-15 km-O-B2-2-1-QSFP28	100G-40 km-O-B2-2-1-QSFP28
7.2.1	yz	yz	yz	yz	yz	yz	yz	yz	yz	yz	yz	yz	yz	yz	yz
7.2.2	o				o				o						
8.2.1		o					o			o					
8.2.5			o								o				
8.2.6					o							o			
8.2.7							o							o	
9.2.1															
9.2.2		o				o							o		
9.2.3				o				o							o
9.2.4															
9.2.5															
9.2.6		o				o							o		
9.2.7				o				o							o
9.2.8															

Table 26: Summary of bidi client (only one pluggable pair using each fiber) pluggables needed for each Blueprint. (* The 100G dual fiber pluggables may also be 4x25G, e.g., 100G-40km-O-L-4-2-QSFP28)

Pluggables vs. Blueprints	10G-10 km-*-C-6-2-SFP+	10G-15 km-C-D-48-2-SFP+	25G-15 km-C-D-48-2-SFP28
8.2.2	x	x	x
8.2.3	o		
8.2.4		o	o
8.2.5		o	o
9.2.4		o	o
9.2.8		o	o

Table 27: Summary of line (multiple pluggable pairs sharing each fiber using WDM) pluggables needed for each Blueprint.

Pluggables vs. Blueprints	GPON-20 km-OS-B3-1-SFP - OLT	GPON-20 km-OS-B3-1-SFP-ONU	GPON-20 km-OS-B3-1-SFP-iONU	XGSPON-20 km-OL-B3-1-SFP+-OLT	XGSPON-20 km-OL-B3-1-SFP+-ONU	XGSPON-20 km-OL-B3-1-SFP+-iONU	25GSPON-20 km-O-B3-1-SFP28-OLT	25GSPON-20 km-O-B3-1-SFP28-ONU	25GSPON-20 km-O-B3-1-SFP28-iONU
	V	Z	Z	V	Z	Z	V	Z	Z
9.2.9	o	o		o	o		o	o	
9.2.10	o		o	o		o	o		o

Table 28: Summary of TDM-PON pluggables needed for each Blueprint.

11. Summary of important technologies, capabilities, and components not yet available

This section discusses technologies and features that are not yet available in current products but that are relevant to the evolution of the Blueprints described in the previous sections. The focus is on pluggable devices: other technological trends from which radio equipment could benefit, like co-packaged optics (CPO), are not covered by the current version of this paper.

11.1. Optical transceivers operating at high temperature

Optical transceivers operating at high temperatures are relevant to any equipment that may operate in a harsh environment, like the RUs in the Blueprints described in Sections 0 and 8. Telecom transceivers share most of the characteristics developed for datacom applications, but with some important differences. The capability to operate at temperatures higher than 100 °C is probably the most important one, due to the higher density of integrated circuits in new generation radio equipment. Due to the operation in an uncontrolled environment, and limitations in weight and size, solutions commonly used in data centers, such as active cooling, are more difficult to apply in radio systems. High-temperature pluggable transceivers would allow the radio equipment to become smaller and lighter, with positive effects on the speed and cost of network rollouts.

The first industry to use integrated photonics was that of datacom transceivers, where the high volumes enable important investments in new technologies. Unfortunately, while silicon photonics modulators and photodetectors are tolerant to high temperatures, current commercial lasers are not. Quantum dot lasers are a promising but not fully mature technology. External laser sources, placed far from the thermal hot spots, are an alternative solution, proposed today primarily for co-packaged optics.

11.2. Cost effective high-capacity transceivers

Aggregate capacities on the order of 10 Tb/s are already common in WDM metro and long-haul networks, based on 100 Gb/s coherent pluggable modules and their evolution to 400 Gb/s. This is largely sufficient to fulfill even the most challenging requirements of a 5G transport network but a dramatic cost reduction is necessary before optical coherent modules can become suitable for this network segment (for example, see the DWDM Blueprints 8.2.3, 8.2.4, 9.2.8 and 9.2.4 described in the previous sections). We are today far from meeting this target, though integrated photonic technologies can help also in this case, for example integrating multiple optical front ends in a single monolithic InP photonic integrated circuits (PIC). Moving the DSP implementation to a 5 nm or lower scale further helps. However, no significant cost reduction is around the corner for key components like DAC/ADC, local oscillator lasers and modulator drivers. Simplified coherent solutions based on a heterodyne receiver and analogue processing have been proposed but they require high opto-electronic bandwidth and can hardly scale beyond 25 Gb/s.

A first step in the above direction could be a power and cost efficient 80 km 100G ZR in QSFP28 (DCO) form factor, to reduce the power and cost of 100G coherent pluggables and extending the reach of DWDM based CRAN blueprint 8.2.3 and 8.2.4.

Intensity-Modulated Direct-Detection (IM-DD) systems are currently simpler and more cost effective than coherent systems but suffer from poor distance and power budget performance at high bit rates. Extending the operation of NRZ optical interfaces beyond 25 Gb/s needs high-accuracy, tunable chromatic dispersion compensators that may be integrated in a TOSA/ROSA, e.g., based on silicon nitride micro-rings. Increasing the number of modulation symbols, as in PAM4, is an alternative but it impairs receiver sensitivity, implementation complexity and cost. Where the right tradeoff between cost and performance lies, is still an open question. The success of 25 Gb/s in the access part of backhaul is expected to generate the need for single fiber solutions with 40 km reach, for example to extend the reach of the Blueprint 9.2.8, or with a link attenuation equal or higher than 21 dB, as in Blueprint 9.2.7.

11.3. Pluggable optical amplifiers and dispersion compensators

Though tolerated at CO and hub sites, optical amplifiers are not usually allowed at RU and cell sites due to their large footprint, power consumption and cost. Compact optical amplifiers implemented in Pluggable Optical Line System (POLs) would be highly beneficial, in these aspects, for DWDM Blueprints where wavelength filters introduce a high insertion loss (e.g., Blueprints 8.2.3, 8.2.4, 9.2.8 and 9.2.4) and could allow the upgrade at 25 Gb/s or higher bitrate of all current 10 Gb/s installation, which is impossible today due to link attenuation constraints.

Similar considerations hold for Dispersion Compensating Modules (DCM) that are today quite bulky. Pluggable implementations, possibly tunable to fit all practical network design cases and avoid inventory issues, would allow to extend the reach of 25G transceivers beyond 15 km and to continue to use cost effective IM-DD interfaces at bit rates higher than 25 Gb/s.

11.4. Cost-effective tunable filters and wavelength switches

One drawback of current DWDM systems is the need to keep the inventory of all variants of transceivers and OADMs working at different wavelengths. This is impractical in mobile transport applications where installation times and cost must be minimal. Reconfigurable OADMs (ROADM) would relieve operators from installing and storing many variants of fixed OADMs, by replacing them with a single reconfigurable device. However, the ROADMs used in optical metro networks are based on high-performance but expensive Wavelength Selective Switches (WSS). Silicon micro-ring resonators could be a promising technology to realize pluggable and low-cost ROADMs. They apply, for example, to Blueprints 8.2.4 and 9.2.4.

Tunable optical filters enable new mobile transport architectures for the same Blueprints, replacing the OADM with a cost-effective power splitter, according to a broadcast-and-select architecture. Current tunable filters based on MEMS, liquid crystals or thin film filters are either too big or only support a limited number of DWDM channels, as in NG-PON2. New silicon photonics designs would offer decreased size and cost.

12. Solutions under evaluation and future work

12.1. LLS using TDM-PON with separate ONU box

The industry has been exploring the possibility of using TDM-PON to provide connectivity between the RU and DU in a CRAN architecture with a Low Layer Split interface. Some of the challenges to accomplish this are bandwidth and latency.

- **Bandwidth.** LLS has higher bandwidth requirements than HLS. The RU interfaces are typically 10 Gb/s or 25 Gb/s rates. LLS variants that generate variable rate traffic can allow aggregation of several RUs on a 25G TDM-PON (and higher), provided the line rate is not fully used by each RU.
- **Latency.** The latency requirement for LLS is much tighter than HLS, in the order of 25-500 μ s one-way [eCPRIreq]. Several efforts have been made to reduce the latency of TDM-PON in order to allow it to be used for certain distances. The methods include reduced burst sizes in the upstream and a real-time control interface (called Cooperative Transport Interface) between the DU scheduler and the OLT scheduler (called Cooperative DBA). These measures are specified in the following standards documents:
 - O-RAN CTI Specification [ORAN-CTI].
 - ITU-T G series supplement on Cooperative DBA [ITU G.Sup.71].

It should be noted that the Cooperative DBA and CTI concepts are still experimental and real-world conditions will be needed for the assessment of their potential.

An illustration for TDM-PON for LLS using an external ONU is shown in Figure 34.

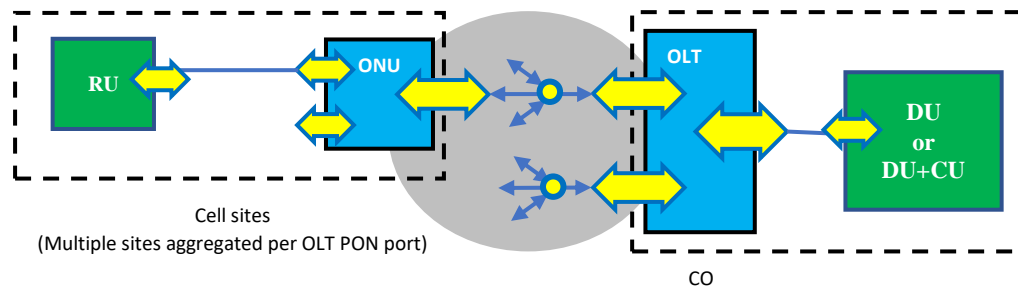

Figure 34: LLS using TDM-PON with separate ONU box.

12.2. LLS using TDM-PON with pluggable ONU

An illustration for TDM-PON for LLS using a pluggable ONU is shown in Figure 35. The ONU functionalities must be built into the optical module itself.

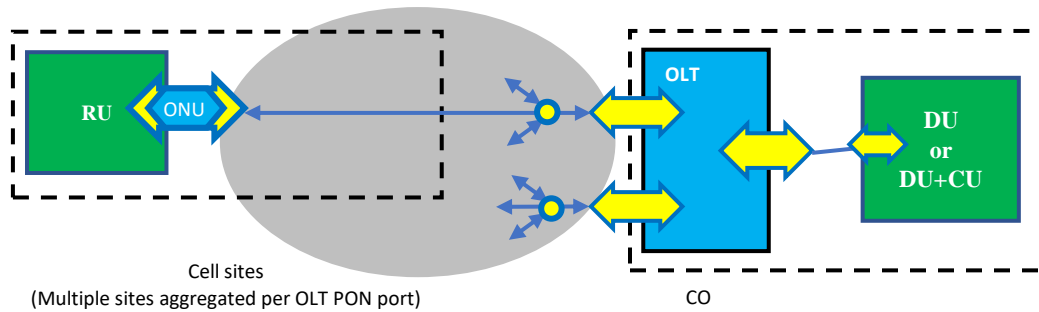

Figure 35: LLS using TDM-PON with a pluggable ONU module.

12.3. Higher speed TDM-PON technologies

The currently defined and available TDM-PON technology above 10G per wavelength is 25GS-PON [25GSPON]. ITU-T has specified Higher Speed PON (HSP) [G.9804.x] for asymmetrical 50/25 Gb/s. The specification for the physical layer of a 50G/50G symmetrical variant of HSP is still work in progress in ITU-T [G.9804.3]. The use of these higher speed PONs will be gated by the economic availability of new technology needed to make them possible.

12.4. LLS using semi-active DWDM wavelength multiplexed links over a power splitter ODN (WS-WDM-PON)

An architecture that is being explored by several operators who have an extensive power splitter PON network is an overlay of DWDM wavelengths on the same Power Splitter ODN (PS-ODN) to serve designated RUs that may be located within the area served by the TDM-PON. The dedicated wavelengths can be an effective way of meeting the high bit rate and low latency requirements of LLS while leveraging the existing PON infrastructure. The main difference of this Wavelength Selected WS-WDM-PON architecture from the typical semi-active DWDM wavelength architecture (Wavelength Routed WR-WDM-PON) is that a power splitter is used as the branching node rather than a wavelength Mux.

There are two added challenges for WS-WDM-PON:

- Higher insertion loss: typical PON optical budget classes range from 29 to 35 dB. Techniques that can help address this target include the use of FEC and higher power optics.
- Wavelength selection on the receive side: this will require a tunable filter at the RU end in addition to the tunable lasers that are part of the traditional DWDM optics.

On the other hand, it is assumed that fewer wavelengths will be needed per PON for WS-WDM-PON than for WR-WDM-PON since the ODN is expected to be shared as an overlay with other TDM-PONs that have existing PON end-points. In most cases, four wavelengths (and at most eight wavelengths)

will be sufficient since most of the PON splitter ports are assumed to be serving other applications. The P2P overlay wavelengths can operate at 10 Gb/s or 25 Gb/s.

An illustration for this WDM architecture with a power splitter ODN is shown below. What is not shown is the coexistence on the same fiber of other legacy TDM-PONs. There is no interaction between these, other than the fact that they share a common fiber. But they are on independent wavelengths, just like there are many independent radio frequencies operating in the air at the same time, with no interaction between them.

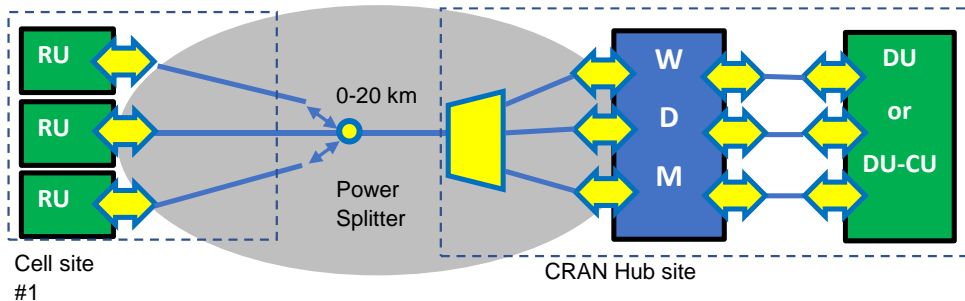

Figure 36: LLS using semi-active DWDM wavelength multiplexed links over a power splitter ODN (WS-WDM-PON).

12.5. LWDM

LWDM (Local Area Network Wavelength Division Multiplexing) is a new WDM technology with the following characteristics:

- Up to 10 km LWDM P2P links
- 25.78 Gb/s / 24.33 Gb/s SFP28
- Dual fiber SFP+, single fiber trunk
- 12 wavelengths @ 800 GHz spacing, i.e., up to 6 SFP+ pairs using the same single trunk fiber:
 - L01 236.2 THz 1269.23 nm
 - L02 235.4 THz 1273.54 nm
 - L03 234.6 THz 1277.89 nm
 - L04 233.8 THz 1282.26 nm
 - L05 233.0 THz 1286.66 nm
 - L06 232.2 THz 1291.10 nm
 - L07 231.4 THz 1295.56 nm
 - L08 230.6 THz 1300.05 nm
 - L09 229.8 THz 1304.58 nm
 - L10 229.0 THz 1309.14 nm
 - L11 228.2 THz 1313.73 nm
 - L12 227.4 THz 1318.35 nm
- Wavelength plan example: L01~L06 for RU, L07-L12 for DU/CU

Channel insertion loss: 4 dB for 10 km fiber (0.4 dB/km), 2 dB for connector loss (4*0.5 dB), 4.5 dB per WDM mux/demux pair, total 10.5 dB.

Power consumption class: PC3 (1.8W maximum power dissipation).

Being a new technology, the market impact and deployment volumes are not yet known.

12.6. 50 Gb/s xWDM 15 km LLS blueprint

50 Gb/s is the next data rate to be employed to address the increasing bandwidth requirement in LLS links. 50 Gb/s gray optics are already available in QSFP28 form factor and are being introduced in SFP56 form factor. Similar to other rates, xWDM is likely needed for use cases such as those illustrated in chapter 8.2.3 (15 km RU-DU, passive DWDM over a single fiber Blueprint), chapter 8.2.4 (15 km RU-DU, passive DWDM bus over a single fiber Blueprint) and chapter 8.2.5 (15 km RU-DU, semi-active DWDM over a single fiber Blueprint).

The target characteristics are as follows:

- Up to 15 km P2P links
- SFP56 form factor
- Industrial temperature range (-40 °C to 85 °C)
- 48 channels.
- Wavelength grid and insertion loss budget are under study.

Annex A "50 Gb/s xWDM 15 km LLS blueprint" provides further details.

13. Conclusion

Optical solutions are essential enablers for the global 5G rollouts, as they bring capacity and performance needed for 5G and future 6G transport.

Driven by the acceleration of 5G deployments and consumer adoption, MOPA proposes a common view and understanding of the optical solutions needed for 5G transport (fronthaul and backhaul).

The aim is to solve the current challenges faced by operators, system vendors and optical pluggable suppliers—specifically ambiguity and complexity—and enable them to make the right technology choices and focus on the most relevant needs of the industry. MOPA benefits the whole ecosystem by ensuring timely, cost-efficient, and optimized architectures.

14. References

- [OptConn] S. Dahlfort, et al. "5G Mobile Pluggables - Blueprints for Global Deployments", <https://opticalconnectionsnews.com/webinars/optical-connections-webinar-series-5g/>
- [M2083] ITU-R Rec. M.2083-0 "IMT Vision – Framework and overall objectives of the future development of IMT for 2020 and beyond", Sept 2015
- [G8300] ITU-T Rec. G.8300: "Characteristics of transport networks to support IMT-2020/5G", May 2020
- [Wiki5G] <https://en.wikipedia.org/wiki/5G>
- [LTEbands] https://en.wikipedia.org/wiki/LTE_frequency_bands
- [NRbands] https://en.wikipedia.org/wiki/5G_NR_frequency_bands
- [TS38306] 3GPP TS 38.306 V16.1.0 (2020-07).
- [TS38470] 3GPP TS 38.470 V16.3.0 (2020-09) "Technical Specification Group Radio Access Network; NG-RAN; F1 general aspects and principles (Release 16)"
- [TS38801] 3GPP TR 38.801 V14.0.0 (2017-03): "Study on new radio access technology: Radio access architecture and interfaces (Release 14)"
- [GSTR-TN5G] ITU-T Technical Report GSTR-TN5G: <http://handle.itu.int/11.1002/pub/8124d287-en>
- [OIF-Thermal] OIF: Implementation Agreement for Thermal Interface Specification for Pluggable Optics Modules, IA # OIF-Thermal-01.0, May 18th 2015
- [ETS-EMC] ETS 300 386, ETSI: Public Telecommunications Network Equipment EMC Requirements
- [FCC15] FCC Part 15, Federal Communications Commission (USA) - Part 15 (Radio Frequency Devices)
- [TDM-PON] https://www.itu.int/en/ITU-T/studygroups/2017-2020/15/Documents/OFC2018-2-Q2_v5.pdf , <https://www.itu.int/rec/T-REC-G.Sup66-202009-l/en>
- [G.652] ITU-T Rec. G.652 "Characteristics of a single-mode optical fibre and cable". Nov 2016
- [G.698.2] ITU-T Rec. G.698.2 "Amplified multichannel dense wavelength division multiplexing applications with single channel optical interfaces". Nov 2018
- [G.694.2] ITU-T Rec. G.694.2 "Spectral grids for WDM applications: CWDM wavelength grid", Dec 2003
- [G.9802.x] ITU-T Rec. G.9802, G.9802.1, G.9802.2 (work in progress) "Wavelength division multiplexed passive optical networks (WDM PON)"
- [G.9804.x] ITU-T Rec. G.9804.1, G.9804.2, G.9804.3 (work in progress) "Higher speed passive optical networks (HSP)"
- [G.9807.x] ITU-T Rec. G.9807.1, G.9807.2 "10-Gigabit-capable symmetric passive optical network (XGS-PON)"
- [G.984.x] ITU-T Rec. G.984.1, G.984.2, G.984.3, G.984.4, G.984.5, G.984.6, G.984.7 "Gigabit-capable passive optical networks (GPON)"
- [G.989.x] ITU-T Rec. G.989.1, G.989.2, G.989.3 "40-Gigabit-capable passive optical networks (NG-PON2)
- [eCPRIreq] CPRI. "Transport Network V1.2 (2018-06-25) Requirements Specification Common Public Radio Interface: Requirements for the eCPRI Transport Network"
- [ORAN-CTI] O-RAN Technical Specification WG4.CTI-TCP.0-v01.00 "Cooperative Transport Interface Transport Control Plane Specification", 2020 (v2 2021 pending).
O-RAN Technical Specification WG4.CTI-TMP.0-v01.00 "Cooperative Transport Interface Transport Management Plane Specification", 2020 (v2 2021 pending)
- [G.Sup.71] ITU-T series G Supplement 71 "OLT Capabilities for supporting CO DBA" (publication pending)

[IEC61753]	IEC 61753-021-2, "Fibre optic interconnecting devices and passive components performance standard - Part 021-2: Grade C/3 single-mode fibre optic connectors for category C - Controlled environment", Dec 2007
IEC 61753-022-2	Fibre optic interconnecting devices and passive components - Performance standard - Part 022-2: Fibre optic connectors terminated on multimode fibre for category C - Controlled environment
[25GSPON]	25G PON MSA group, "25GS-PON Specification: 25 Gigabit Symmetric Passive Optical Network" v2.0, Aug 2021
[10GEAPON]	IEEE 802.3av-2009 "Part 3: Carrier Sense Multiple Access with Collision Detection (CSMA/CD) Access Method and Physical Layer Specifications, Amendment 1: Physical Layer and Management Parameters for 10Gb/s Passive Optical Networks", Clause 75 IEEE 802.3bk "Amendment 1 to 802.3-2012: Physical Layer Specifications and Management Parameters for Extended Ethernet Passive Optical Networks"
[802.3ca]	IEEE 802.3ca-2020 "Amendment 9: Physical Layer Specifications and Management Parameters for 25 Gb/s and 50 Gb/s Passive Optical Networks", Clause 141
[SmartT]	smarttunable-msa.org
[ER-6G-Spectrum]	https://www.ericsson.com/en/blog/2022/6/6g-spectrum-why-its-fundamental
[Hexa-X]	https://www.ericsson.com/en/blog/2021/1/hexa-x-initiative-to-shape-6g

Appendix A: Referenced Physical Layer Standards Exceptions for MOPA Blueprints

Existing standards and implementation agreements produced by Standards Development Organizations (SDOs), Industry Fora and multi-source agreements (MSAs), where the Blueprints cover the different technical aspects, can help form a broad description of optical solutions useful and important for mobile transport networks. MOPA is working actively to contribute to SDOs such as ITU-T and IEEE to provide requirements and perspective from mobile optics and in general to align the industry. Related to such requirements are formfactors for next generation speed upgrades: In Chapters 7 and 8 and the blueprints dealing with direct parallel fiber LLS links, 100 Gb/s is not yet included for p2p links and for blueprints dealing with packet multiplexing, so far only QSFP28 formfactor has been listed. However, due to tight requirements on footprint and power consumption (due to stringent thermal requirements) the serial SFP format is favored for radio units. Thus, SFP112 formfactor will most likely be added to the LLS p2p blueprints in the next paper revisions.

The tables in this Appendix show the various MOPA Blueprints described in Chapters 7, 8 and 9 along with an industry specification(s) that is closely aligned *or nearly aligned (with exceptions)*. The table rows below "Parameters" list parameters where there are significant differences and where the MOPA Blueprint requirements are not fulfilled. In the case where there are such parameter exceptions, the intent is that they are relatively minor and will allow optics suppliers to leverage existing high-volume transceiver solutions. These tables are informative guidelines.

2 km, 10/25/50G, dual-fiber	10 Gb/s		25 Gb/s		50 Gb/s	
	10G-2km-O-G-1-2-SFP+		25G-2km-O-G-1-2-SFP28		50G-2km-O-G-1-2-SFP56	
	IEEE 802.3 Cl. 52 (10GBASE-L)*	MOPA Blueprint	IEEE 802.3 Cl. 114 (25GBASE-LR)*	MOPA Blueprint	IEEE802.3 Cl. 139 (50GBASE-LR)*	MOPA Blueprint
Parameter		No exceptions		No exceptions		No exceptions

Table APA.1: 2 km, dual-fiber, Blueprints. Insertion loss (IL) budget = 2.8 dB in O-band. *The insertion loss budgets for these IEEE specifications (IL = 6.3 dB, for up to 10 km) may be viewed as overengineered and not be cost optimized for the corresponding MOPA Blueprint.

2 km, 10/25/50G, BiDi	10 Gb/s		25 Gb/s		50 Gb/s	
	10G-2km-O-B2-2-1-SFP+		25G-2km-O-B2-2-1-SFP28		50G-2km-O-B2-2-1-SFP56	
	IEEE 802.3 Cl. 158 (10GBASE-BR10)*	MOPA Blueprint	IEEE 802.3 Cl. 159 (25GBASE-BR10)*	MOPA Blueprint	IEEE 802.3 Cl. 160 (50GBASE-BR10)*	MOPA Blueprint
Parameter		No exceptions		No exceptions		No exceptions

Table APA.2: 2 km, BiDi, Blueprints. IL budget = 2.8 dB in O-band. *The link budgets for these IEEE specifications (IL = 6.3 dB, for up to 10 km) may be viewed as overengineered and not be cost optimized for the corresponding MOPA Blueprint.

2 km, 10/25/50G, BiDi	10 Gb/s		25 Gb/s		50 Gb/s	
	10G-2km-O-B2-2-1-SFP+		25G-2km-O-B2-2-1-SFP28		50G-2km-O-B2-2-1-SFP56	
Parameter	ITU-T G.9806 Amend. 2* (Tables 7-1, 7-2)	MOPA Blueprint	ITU-T G.9806 Amend. 2* (Tables 7-1, 7-2)	MOPA Blueprint	ITU-T G.9806 Amend. 2* (Tables 7-1, 7-2)	MOPA Blueprint
Wavelength				Recommend IEEE wavelength range		Recommend IEEE wavelength range

Table APA.3: Alternative referenced standards for 2 km, BiDi, Blueprints. IL budget = 2.8 dB in O-band. *The link budgets for these ITU specifications (S class, IL = 15 dB) may be viewed as overengineered and not be cost optimized for the corresponding MOPA Blueprint.

2 km, 100G, dual-fiber, BiDi	100 Gb/s (Dual-Fiber)		100 Gb/s (BiDi)	
	100G-2km-O-G-1-2-QSFP28 or 100G-2km-O-C/L-4-2-QSFP28		100G-2km-O-B2-2-1-QSFP28	
Parameter	IEEE 802.3 Cl. 140 (100GBASE-FR1) or 100G CWDM4 MSA	MOPA Blueprint	IEEE 802.3dk* or ITU-T G.9806 (Amend 3)*	MOPA Blueprint
		No exceptions		TBD

Table APA.4: 2 km, 100 Gb/s, dual-fiber and BiDi Blueprints. IL budget = 2.8 dB in O-band. *In progress.

10 km, 10/25/50G, dual-fiber	10 Gb/s		25 Gb/s		50 Gb/s	
	10G-10 km-O-G-1-2-SFP+		25G-10km-O-G-1-2-SFP28		50G-10km-O-G-1-2-SFP56	
Parameter	IEEE 802.3 Cl. 52 (10GBASE-LR)	MOPA Blueprint	IEEE 802.3 Cl. 114 (25GBASE-LR)	MOPA Blueprint	IEEE802.3 Cl. 139 (50GBASE-LR)	MOPA Blueprint
Wavelength	1260-1355 nm	1260-1355 nm	1295-1325 nm	1295-1325 nm	1304.5 - 1317.5 nm	1304.5-1317.5 nm
Launch power (min) in OMA minus TDP	-6.2 dBm	-5.4 dBm	-5.0 dBm	-4.3 dBm	-2.9 dBm	-2.2 dBm
Optical Modulation Amplitude (min)	-5.2 dBm	-4.4 dBm	-4.0 dBm	-3.3 dBm	-1.5 dBm	-0.8 dBm

Table APA.5: 10 km, dual-fiber, Blueprint. IL budget = 7 dB in O-band. Since the MOPA IL budget is higher than the one used by IEEE, the MOPA blueprint would use the IEEE specification with a slightly increased launch power and optical modulation amplitude. Also, the wavelength range is tightened compared to the full O-band.

10 km, 10/25/50G, BiDi	10 Gb/s		25 Gb/s		50 Gb/s	
	10G-10km-O-B2-2-1-SFP+		25G-10km-O-B2-2-1-SFP28		50G-10km-O-B2-2-1-SFP56	
	<i>IEEE 802.3 Cl. 158 (10GBASE-BR10)</i>	<i>MOPA Blueprint</i>	<i>IEEE 802.3 Cl. 159 (25GBASE-BR10)</i>	<i>MOPA Blueprint</i>	<i>IEEE 802.3 Cl. 160 (50GBASE-BR10)</i>	<i>MOPA Blueprint</i>
Parameter						
Wavelength	1270/1330 nm (±10 nm)	1270/1330 nm (±10 nm)	1270/1330 nm (±10 nm)	1270/1330 nm (±10 nm)	1270/1330 nm (±10 nm)	1270/1330 nm (±10 nm)
Launch power (min) in OMA minus TDP	-6.2 dBm	-5.4 dBm	-5.0 dBm	-4.3 dBm	-2.9 dBm	-2.2 dBm
Optical Modulation Amplitude (min)	-5.2 dBm	-4.4 dBm	-4.0 dBm	-3.3 dBm	-1.5 dBm	-0.8 dBm

Table APA.6: 10 km, BiDi, Blueprint. IL budget = 7 dB in O-band. Since the MOPA IL budget is higher than the one used by IEEE, the MOPA blueprint would use the IEEE specification with a slightly increased launch power and optical modulation amplitude.

10 km, 10/25/50G, BiDi	10 Gb/s		25 Gb/s		50 Gb/s	
	10G-10km-O-B2-2-1-SFP+		25G-10km-O-B2-2-1-SFP28		50G-10km-O-B2-2-1-SFP56	
	<i>ITU-T G.9806 Amend. 2* (Tables 7-1, 7-2)</i>	<i>MOPA Blueprint</i>	<i>ITU-T G.9806 Amend. 2* (Tables 7-1, 7-2)</i>	<i>MOPA Blueprint</i>	<i>ITU-T G.9806 Amend. 2* (Tables 7-1, 7-2)</i>	<i>MOPA Blueprint</i>
Parameter						
Wavelength	1270/1330nm (±10nm)	1270/1330nm (±10nm)	1289/1314nm (±8nm)	<i>Recommend IEEE wavelength range</i>	1289/1314nm (±8nm)	<i>Recommend IEEE wavelength range</i>
		<i>No other exceptions</i>		<i>No other exceptions</i>		<i>No other exceptions</i>

Table APA.7: Alternative referenced standards for 10 km, BiDi, Blueprint. IL budget = 7 dB in O-band. *The link budgets for these ITU specifications (S class, IL = 15 dB) may be viewed as overengineered and not be cost optimized for the corresponding MOPA Blueprint.

10 km, 100G, Dual-fiber, BiDi	100 Gb/s (Dual-Fiber)		100 Gb/s (BiDi)	
	100G-10km-O-C/L-4-2-QSFP28 or 100G-10km-O-G-1-2-QSFP28		100G-10km-O-B2-2-1-QSFP28	
	IEEE 802.3 Clause 88 (100GBASE-LR4) or Clause 140 (100GBASE-LR1)	MOPA Blueprint	IEEE 802.3dk* or ITU-T G.9806 (Amend. 3)*	MOPA Blueprint
Parameter				
Wavelength	1294.53 to 1310.19 nm (LAN WDM) or 1304.5 to 1317.5 nm	1294.53 to 1310.19 nm (LAN WDM) or 1304.5 to 1317.5 nm	-	TBD
Launch power (min) in OMA minus TDECQ	-2.3 dBm or -1.5 dBm	-1.6 dBm or -0.8 dBm	-	TBD
Optical Modulation Amplitude (min)	-1.3 dBm or -0.1 dBm	-0.6 dBm or +0.6 dBm	-	TBD

Table APA.8: 10 km, 100 Gb/s, dual-fiber and BiDi Blueprints. IL budget = 7.0 dB in O-band. For dual-fiber: Since the MOPA IL budget is higher than the one used by IEEE, the MOPA blueprint would use the IEEE specification with a slightly increased launch power and optical modulation amplitude *In progress.

15 km, 10/25/50G, Dual-fiber	10 Gb/s		25 Gb/s		50 Gb/s	
	10G-15km-O-G-1-2-SFP+		25G-15km-O-G-1-2-SFP28		50G-15km-O-G-1-2-SFP56	
	IEEE 802.3 Cl. 158 (10GBASE-BR20)*	MOPA Blueprint	IEEE 802.3 Cl. 159 (25GBASE-BR20)*	MOPA Blueprint	IEEE 802.3 Cl. 160 (50GBASE-BR20)*	MOPA Blueprint
Parameter						
Wavelength	1270/1330nm (±10nm)	1260 – 1340nm	1289/1314nm (±8nm)	1281-1322nm	1289/1314nm (±8nm)	1281-1322nm

Table APA.9: 15 km, dual-fiber, Blueprint. IL budget = 9 dB in O-band. *The 20 km BiDi specification (IL budget = 15 dB) is used as a basis as being the specification closest exceeding the MOPA IL requirement for 15 km. However, here the system would not use the diplexer.

15 km, 10/25/50G BiDi	10 Gb/s		25 Gb/s		50 Gb/s	
	10G-15km-O-B2-2-1-SFP+		25G-15km-O-B2-2-1-SFP28		50G-15km-O-B2-2-1-SFP56	
	IEEE 802.3 Cl. 158 (10GBASE-BR20)*	MOPA Blueprint	IEEE 802.3 Cl. 159 (25GBASE-BR20)*	MOPA Blueprint	IEEE 802.3 Cl. 160 (50GBASE-BR20)*	MOPA Blueprint
Parameter						
Wavelength		No exceptions	1289/1314nm (±8nm)	1289/1314nm (±8nm)	1289/1314nm (±8nm)	1289/1314nm (±8nm)

Table APA.10: 15 km, BiDi, Blueprint. IL budget = 9 dB in O-band. *The BR20 link budget = 15 dB may be viewed as overengineered and not be cost optimized for the corresponding MOPA Blueprint.

15 km, 100G Dual-fiber, BiDi	100 Gb/s (Dual-Fiber)		100 Gb/s (BiDi)	
	100G-15km-O-C/L-4-2-QSFP28 or 100G-15km-O-G-1-2-QSFP28		100G-15km-O-B2-2-1-QSFP28	
	100G 4WDM-20 [†] or 100G Lambda MSA (100G-LR1-20) ^{††}	MOPA Blueprint	IEEE 802.3dk* or ITU-T G.9806 (Amend. 3)*	MOPA Blueprint
Parameter		No exceptions		TBD

Table APA.11: 15 km, 100 Gb/s, dual-fiber and BiDi Blueprints. IL budget = 9 dB in O-band. [†]The link budget for this specification (IL = 10.2 dB) may not be cost optimized for the corresponding MOPA Blueprint. ^{††}The link budget for this specification (IL = 9.8 dB) may not be cost optimized for the corresponding MOPA Blueprint. *In progress.

15 km, 10/25G CWDM	10 Gb/s		25 Gb/s	
	10G-10km-*-C-6-2-SFP+			
	ITU-T G.695 (07/2018)	MOPA Blueprint	O-RAN WG9 WDM 0-v02.00 [†]	MOPA Blueprint
Parameter		Use Table 8-15 as starting point for a 6-wavelength interface		TBD

Table APA.12: 10 km, CWDM Blueprint. IL loss budget = 11.5 dB. [†]In progress

15 km, 10/25G DWDM	10 Gb/s		25 Gb/s	
	10G-15km-C-D-48-2-SFP+		25G-15km-C-D-48-2-SFP28	
	ITU-T G.698.1 (11/2009) Table 8-3	MOPA Blueprint	-	MOPA Blueprint
Parameter		No exceptions*		TBD

Table APA.13: 15 km, DWDM Blueprint. IL budget = 17.8 dB in C-band. *ITU-T specification supports 1000 ps/nm of chromatic dispersion which is more than the 270 ps/nm assumed for 15 km of standard G.652 SMF.

40 km, 10/25/100G Dual-fiber	10 Gb/s		25 Gb/s		100 Gb/s	
	10G-40 km-C-G-1-2-SFP+		25G-40 km-O-G-1-2-SFP28		100G-40 km-O-L-4-2-QSFP28 or 100G-40 km-O-G-1-2-QSFP28	
	IEEE 802.3 Cl 52 (10GBASE-ER)	MOPA Blueprint	IEEE 802.3 Cl 114 (25GBASE-ER)	MOPA Blueprint	IEEE 802.3 Cl. 88 (100GBASE-ER4) Or 100G Lambda MSA (100G-ER1-40)	MOPA Blueprint
Parameter						
Wavelength	1530 to 1565 nm	-	1295 to 1310 nm	-	1294.53 to 1310.19 nm or 1308.09-1310.19 nm	-
Launch power (min) in OMA minus TDP	-2.1 dBm	+2.0 dBm*	-1.0 dBm	+2.0 dBm*	+0.1 dBm or +3.3 dBm	+3.1 dBm* Or +6.3 dBm*
Optical Modulation Amplitude (min)	-1.7 dBm	+2.4 dBm*	0.0 dBm	+3.0 dBm*	NA or +4.7 dBm	NA or +7.7 dBm*

Table APA.14: 40 km, dual-fiber, Blueprint. IL budget = 21 dB in O-band or 15 dB in C-band. Since the MOPA IL budget is higher than the one used by IEEE, the MOPA blueprint would use the IEEE specification with an increased launch power and optical modulation amplitude. *Such high optical modulation amplitude may not be achievable with available cost-effective technology.

40 km, 10/25/100G BiDi	10 Gb/s		25 Gb/s		100 Gb/s	
	10G-40 km-O-B2-2-1-SFP+		25G-40 km-O-B2-2-1-SFP28		100G-40 km-O-B2-2-1-QSFP28	
	IEEE 802.3 Cl. 158 (10GBASE-BR40)	MOPA Blueprint	IEEE 802.3 Cl. 159 (25GBASE-BR40)	MOPA Blueprint	IEEE 802.3dk [†] or ITU-T G.9806 (Amend. 3 [†])	MOPA Blueprint
Parameter						
Wavelength		No exceptions	1314/1289nm	1314/1289nm		TBD
Launch power (min) in OMA minus TDP	-1.0 dBm	+2.0 dBm*	-1.0 dBm	+2.0 dBm*		TBD
Optical Modulation Amplitude (min)	0.0 dBm	+3.0 dBm*	0.0 dBm	+3.0 dBm*		TBD

Table APA.15: 40 km, BiDi, Blueprint. Insertion loss budget = 21 dB in O-band. Since the MOPA IL budget is higher than the one used by IEEE, the MOPA blueprint would use the IEEE specification with an increased launch power and optical modulation amplitude. *Such high optical modulation amplitude may not be achievable with available cost-effective technology. †In progress.

TDM-PON	2.5/1.25 Gb/s		10/10 Gb/s		25 / 10 Gb/s or 25 Gb/s	
	GPON-20 km-OS-B3-1-SFP-OLT GPON-20 km-OS-B3-1-SFP-ONU		XGS-PON-20 km-OL-B3-1-SFP+-OLT XGS-PON-20 km-OL-B3-1-SFP+-ONU		25GS-PON-20 km-O-B3-1-SFP28-OLT 25GS-PON-20 km-O-B3-1-SFP28-ONU	
	ITU-T G.984.2	MOPA Blueprint	IEEE 802.3 Clause 75 (10GBASE-PR-D/U3) or ITU-T G.9807.1(Amend 2) (Annex B)	MOPA Blueprint	IEEE 802.3 Clause 141 (25/10-PQ30X) (25/25-PQ30X) or 25GS-PON MSA V2.0	MOPA Blueprint
Parameter						
IL Budget	28dB	No exceptions	33 dB or up to 35 dB	No exceptions	29 dB or 31 dB	No exceptions

Table APA.16: 20 km TDM-PON Blueprint. Multiple insertion loss classes from 28 dB to 35dB depending on configuration and data-rate.

Appendix B: Optical pluggable performance for tight synchronization

1. Introduction - Impact of pluggables on transported time synchronization

In a packet transport network using PTP (Precision Time Protocol [PTP]) for time synchronization distribution, PTP timestamping accuracy must be tightly controlled. Any effect, deterministic or stochastic, potentially leading to uplink/downlink propagation delay asymmetry in a link directly impacts the time error budget. The acceptable contribution of pluggables in point-to-point links to overall uplink/downlink delay asymmetry should be a small percentage of the overall requirement for the full system. For TDM-PON systems the delay is inherently asymmetric, and this is circumvented by a termination of PTP at the OLT, the use of TPS-TC (Transport Protocol Specific – Transmission Convergence), and generation of PTP at the ONU side. In the case of TDM-PON the uplink/downlink propagation delays as such are allowed to be different but they must be estimated correctly for a precise distribution of Time of Day to the ONUs.

This document reports a detailed description of node level and link level aspects of accurate sync distribution via PTP, how the characteristics of optical pluggables can impact cTE, and proposes a classification of optical pluggables in order to estimate and compensate for constant time errors.

2. Factors impacting PTP accuracy

In packet transport networks, time synchronization can be transported using **PTP** [PTP]. A time transmitter node provides high accuracy time to a time receiver node, compensating for propagation delays, via time measurements of messages including “time-stamping” in the messages (see Figure APB.1)

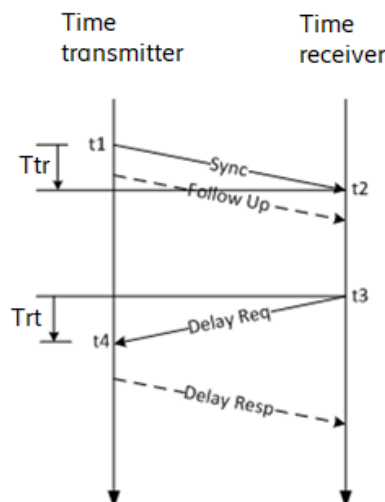

Figure APB.1: Propagation of timing messages.

Time is calculated at the time receiver node with a very simple approach. First, the mean path delay between the two nodes is calculated based on the measured values of t_1 , t_2 , t_3 and t_4 :

$$\text{Delay} = [(t_2 - t_1) + (t_4 - t_3)] / 2 = (\mathbf{T_{tr}} + \mathbf{T_{rt}}) / 2$$

The obtained propagation delay is then used to calculate the time (clock) offset between the time transmitter and the time receiver nodes:

$$\text{Offset (time transmitter to time receiver)} = t_2 - t_1 - \text{Delay} = \mathbf{T_{tr}} - \mathbf{Delay}$$

The two single-ended propagation delays, **T_{tr}** and **T_{rt}** are assumed equal: if they are **different**, half their difference becomes a source of **time error** taken by the time receiver node.

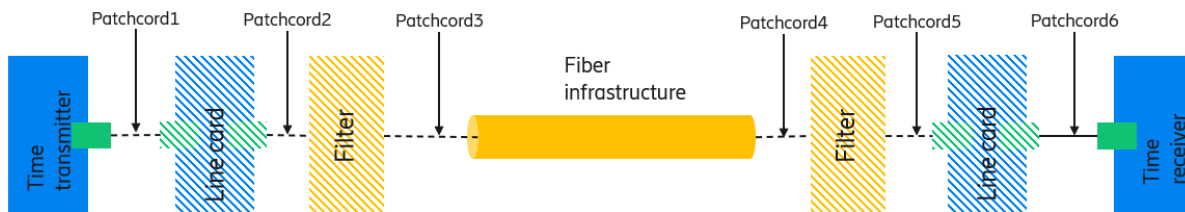

Figure APB.2: Fiber optic system with several possible delay asymmetry contributors.

In fiber optic links, there are several possible contributors to this propagation delay asymmetry (see Figure APB.2):

The most obvious one is the fibers' length mismatch, including patch-cords: considering the flight time of signals in glass fibers (approx. 5 $\mu\text{s}/\text{km}$), *every meter of length mismatch contributes 5 ns of propagation delay asymmetry*. For dual fiber plants, the Tx/Rx fiber patch-cords length mismatch can be minimized using only dual fiber, "matched" patch-cords.

Concerning the outside plant fiber, due to the "loose-tube" construction technology of underground cables, in the worst case two fibers randomly picked from the same cable can exhibit a length mismatch in the range of **3% to 5%**.

BiDi optical interfaces, initially introduced to save fiber, have become popular in the fronthaul space because they allow the removal of this contribution. This highlights a secondary effect of a dual fiber plant, i.e. the impact of fiber chromatic dispersion, causing different wavelengths to propagate at different speeds. This effect can be minimized by limiting the wavelength difference in the two directions. In estimating this contribution, wavelength drifts caused by changes in the operating temperature of the lasers at both ends of the links must be considered, as they may be significant in case of lasers without thermo-electric coolers ("uncooled" lasers). Anyway, this is accounted for if the

worst case, over temperature and lifetime, minimum and maximum wavelengths are used for the estimation.

System internal optical and electronics components in a link can contribute to the worst-case delay asymmetry. One example is WDM optical filter fiber pigtails, which may differ in length depending on the component internal optical paths.

Lastly, optical transceivers and digital integrated circuits on the line cards can contribute to these delay asymmetry values. Standardization bodies⁹ are trying to improve the timestamping accuracy process at system level, but there is no effort to put a cap on the possible contribution from optical pluggables

3. The impact of optical pluggables in link propagation delay asymmetries

For low bit rates (25 Gb/s and below), the internal structure of optical pluggables is simple and mostly “analog” in nature. The most complex electronic part in pluggables can be a simple retimer/CDR (Clock and Data Recovery). The contribution to propagation delay asymmetry of pluggables is determined by the symbol latency through optical and electrical components, and by possible length mismatches in the short PCB (Printed Circuit Board) traces, making it easy to imagine a nanosecond contribution to asymmetry even in a multi-vendor, multi-design environment.

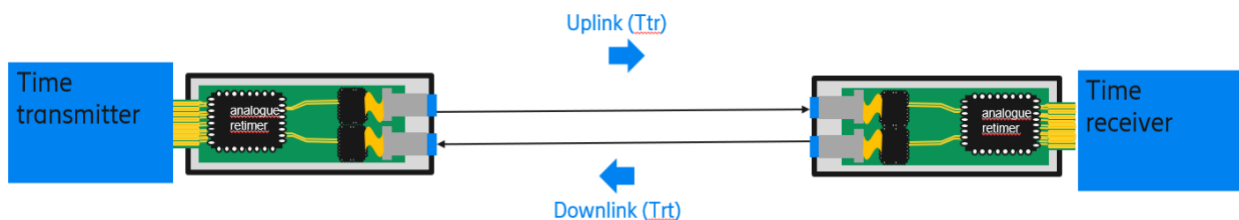

Figure APB.3: Details of a Time transmitter and Time receiver link where the optical pluggables mostly have analogue internal components.

With the rise of higher bit rates (50 Gb/s and higher) and the adoption of advanced modulation formats (PAM-4 or Coherent), complex digital signal processors (DSPs) can appear in optical pluggables. A DSP converts analogue signals into digital and implements complex signal processing functions in the digital domain. In the Tx case, it can also convert the signal back to analogue to drive the optical transmitter.

⁹ The **IEEE P802.3cx** “improving PTP timestamping accuracy” Task Force is working to make the overall timestamping mechanism more precise, especially for high-speed Ethernet aggregates partitioned over several ‘stripes’ or ‘lanes’.

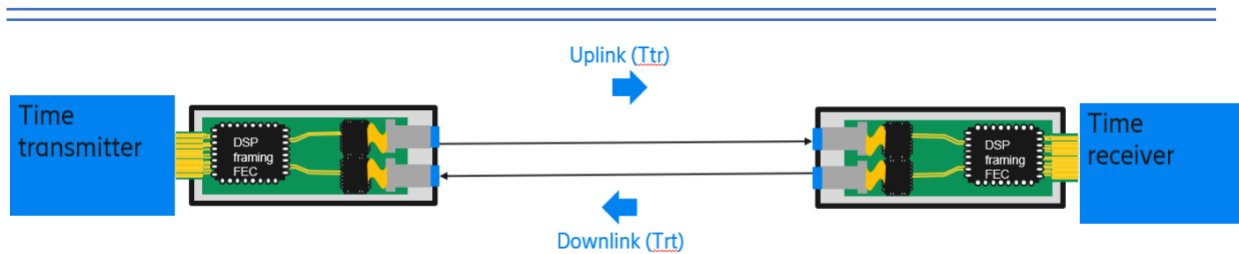

Figure APB.4: Details of a Time transmitter and Time receiver link where the optical pluggables have DSPs.

The presence of DSPs can potentially make **T_{tr}** and **T_{rt}** significantly different, especially if minimizing propagation delay asymmetry was not considered as a design criterion. Different DSP vendors can have different signal pipeline architectures: but also considering a transceiver from a single vendor, with the same DSP on both ends, uplink and downlink signal paths inside the devices are nominally identical but **process/ temperature / supply voltage variations, DSP state machine evolution** different at both ends may introduce a propagation delay asymmetry.

In some cases, even more complex digital functions like gear-boxing, framing and FEC (Forward-Error Correction) can be implemented in the DSP and, if they were designed without the requirement to minimize delay asymmetry, they could easily dominate the contribution of optical pluggables.

System vendors, pluggable vendors and DSP vendors can *collaboratively make future DSP-based optics more “timing and sync friendly”* by characterizing and putting a cap on the propagation delay asymmetry so that the overall contribution of optical pluggables can be engineered in the complete system.

4. “Link” vs. ITU-T “node” views

Not all networks are created equal, and different scenarios may require different tiers of PTP time accuracy. Such scenarios are described in ITU-T G.8271 and G.8271.1, and other relevant recommendations in the G.827x series. The accuracy requirement is described in different categories of Time Alignment Errors between RUs as per 3GPP TS38.104, resulting in a “node” budget for transport Time Errors. The stricter the category, the more stringent the requirement on the network nodes (in terms of their amount and their performance). The synchronization performance of network nodes acting as T-BC (Telecom Boundary Clock) or T-TSC (Telecom- Time Slave Clock) nodes in the synchronization path is described in Classes as indicated in Table 7.3 from G.8273 Annex B:

Table 7-3 – T-BC/T-TSC permissible range of constant time error

T-BC/T-TSC Class	Permissible range of constant time error – cTE(ns)
A	±50
B	±20
C	±10
D	For further study

Figure APB.5: Table 7.3 from G.8273 Annex B.

It covers the so-called “constant time error” contribution (cTE), and describes four accuracy classes, A through D, in decreasing range of permissible time error.

As an example, “Class A” nodes are normally used for mobile backhaul networks (Category C requirements) while “Class B” or “Class C” nodes may be required in fronthaul networks having to support time-sensitive features (TDD, advanced spectrum coordination in FR1 or in FR2, etc.) (Category B or Category A requirements).

“Constant” means “not varying in-service” and seems suitable for pluggable optics: once an optical link is operational, the propagation delay asymmetry introduced by pluggables does not change significantly while a disruptive event (e.g. fiber cut and restore, or changing one of the pluggables on the endpoints to a different vendor) may cause this value to change.

ITU-T G.8273.2 defines time accuracy classes at “node” level, and the way to test time error at node level is indicated in figure APB.6:

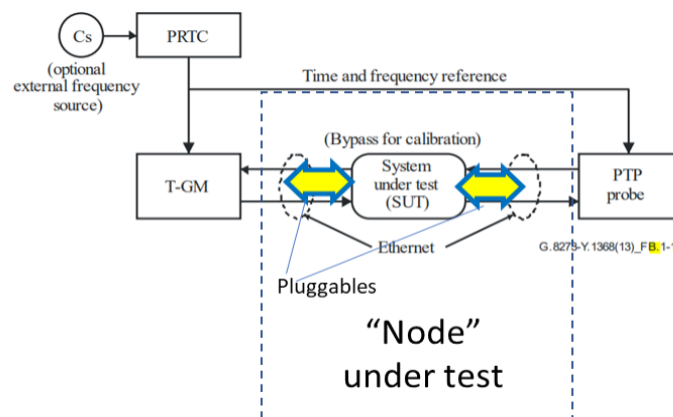

Figure APB.6: Figure B.1.1 from G.8273.2 Annex B.

This “node level” view is not in conflict with the “link level” description of the asymmetries shown previously. Two pluggables enter in the G.8273.2 node test setup, and their Tx/Rx propagation delay differences contribute to the “node level” time error budget. Two pluggables also contribute to the worst-case asymmetry at link level. In both cases, we always must estimate the worst-case propagation delays introduced by a couple of pluggables and to put a cap on their difference.

It’s important of course not to count the pluggables contribution twice: if considering the contribution of pluggables embedded in the “node” classification as per ITU-T, at link level only asymmetries introduced by the fiber plant and infrastructure need be considered.

5. Eliciting transceiver-level requirements from node-level class

The assumption is that the Tx and Rx propagation delays of a transceiver “i” remain within the boundaries of a max and min value, which can be expressed as a **“typical”/average value T0 and R0 plus or minus a respective worst case (maximum) “delta” value** as shown in the diagram in figure APB.7:

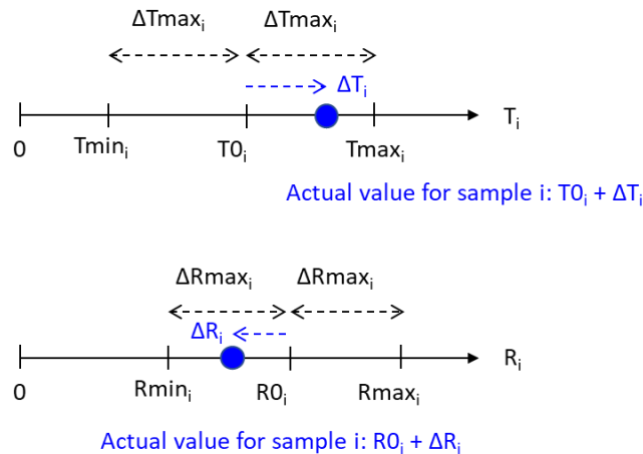

Figure APB.7: Tx and Rx average and delta propagation delay values.

These values can be measured **during Design Validation Testing (DVT)**, by grabbing a population of transceivers and measuring Tx and Rx propagation delays at corners and several times after link re-start conditions.

Considering a *couple* of transceivers “1” and “2”, their **max and min propagation delays** can be written as:

$T_1 = T0_1 \pm \Delta T_{max1}$	$T_2 = T0_2 \pm \Delta T_{max2}$
$R_1 = R0_1 \pm \Delta R_{max1}$	$R_2 = R0_2 \pm \Delta R_{max2}$

“Typical”/average values may be vendor, generation and revision dependent. We could put a loose cap on them (to make sure latency is low) but variations could be accounted for by **storing these “typical” values, T0 and R0, in locations of the internal optical module EEPROM.**

Both Node A and Node B will read the “typical” values from their respective transceivers, effectively moving the *reference planes* at the fiber plant edge. The quasi-static parts (Δ) will contribute to the residual time error budget for optical pluggables. The PTP standard [PTP] describes the compensation for ingress and egress latency asymmetry in a Node. Each node A and B can perform

the compensation individually without needing to exchange these “typical values” between the nodes.

The remaining delay asymmetry would only be dependent on the “quasi-static” contribution per couple of pluggables in a link: $\Delta T_{max_1} + \Delta T_{max_2} + \Delta R_{max_1} + \Delta R_{max_2}$:

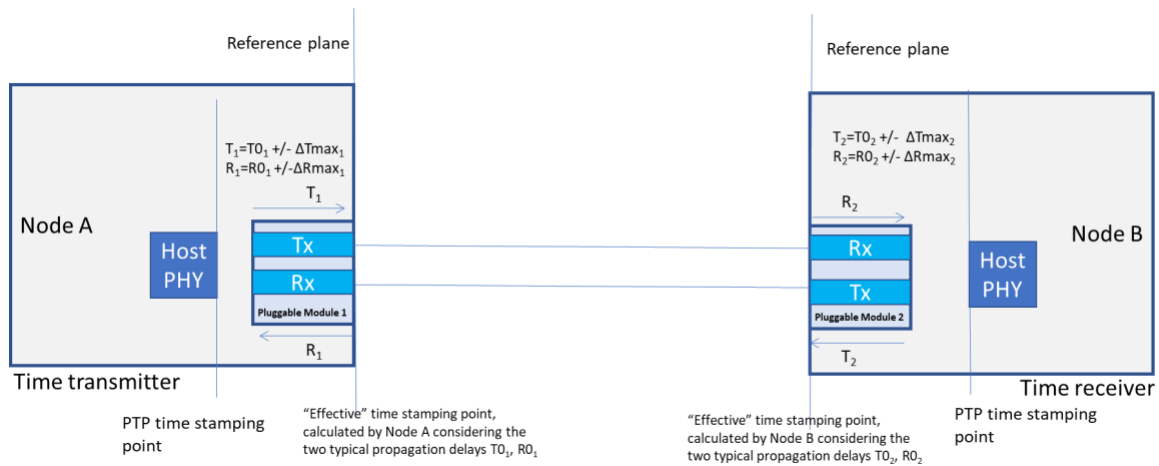

Figure APB.8: Tx and Rx average and delta propagation delay values for optical pluggables in two nodes across an optical link.

Looking now only at one side of a link - for instance, focusing on the time transmitter side:

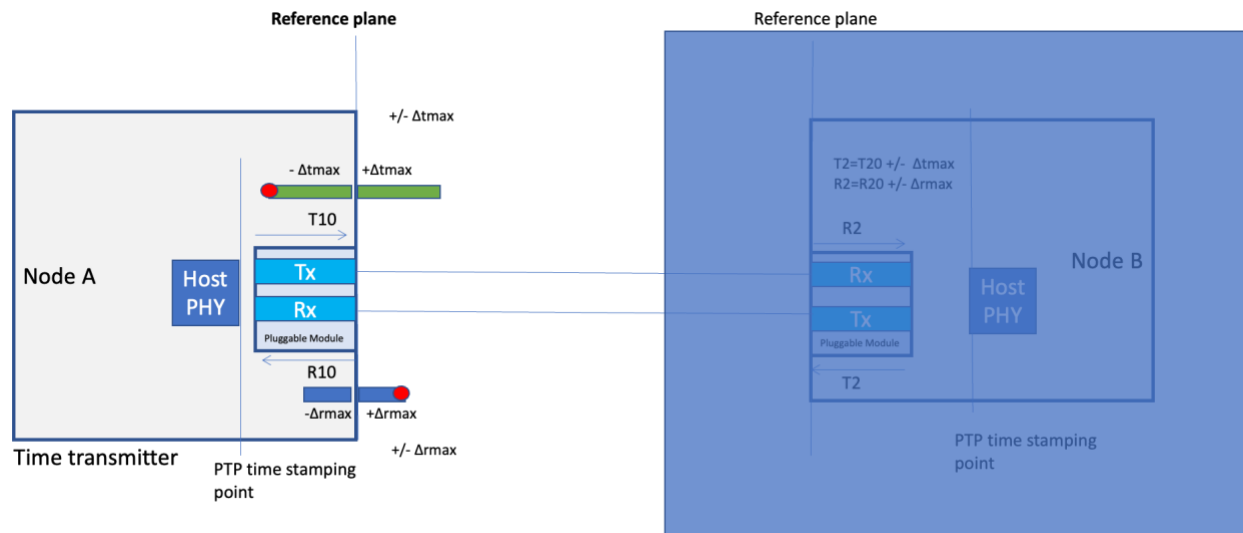

Figure APB.9: Time transmitter side average and delta propagation delay values.

Worst case error on the reference plane position happens when the two deltas on Tx and Rx are of opposite sign, so the max cTE added will simply be $\frac{1}{2} * (\Delta T_{max} + \Delta R_{max})$.

6. A methodology define propagation to delay accuracy classes of optical pluggables

Pluggable propagation delay accuracy classes can be based on “node” classes, by adding a simple percentage number.

An “**X.Y**” class pluggable would support node-level accuracy **Class X** and consume **Y%** of the relevant cTE budget (see Table APB.1 below where the G.8273.2 “node” accuracy classes are listed again for convenience). This creates a link between the node/application level and optical pluggables and defines the target optical pluggables specification.

G.8273.2 “node” accuracy classes	Class A	Class B	Class C
Max constant time error	+/-50ns	+/-20ns	+/-10ns

Table APB.1: G.8273.2 “node” accuracy classes.

For example, a “Class C.2” pluggable consumes 2% of the cTE budget ITU-T G.8273.2 allocates for Class C nodes and hence its worst-case contribution to cTE is equal to +/-0.2ns, translating in both ΔT_{max} and ΔR_{max} = +/-0.2ns. Such target values appear achievable for very simple pluggable implementations, maintaining an analogue signal chain.

A “Class A.20” pluggable instead consumes 20% of the cTE budget ITU-T G.8273.2 allocates for Class A nodes and hence its worst-case contribution to cTE is equal to +/-10ns, translating in both ΔT_{max} and ΔR_{max} = +/-10ns. These target values should enable use of quite complex digital parts inside the pluggable,

In table APB1.2 we propose a meaningful definition of pluggable transceiver classes, in decreasing order of worst case cTE contribution:

	Class A.10	Class A.20	Class B.10	Class B.20	Class C.2	Class C.10
Max constant time error budget allocated to one pluggable	+/- 5ns	+/-10ns	+/- 2ns	+/- 4ns	+/- 0.2ns	+/- 1ns
	$\Delta T_{max}=\pm 5ns$	$\Delta T_{max}=\pm 10ns$	$\Delta T_{max}=\pm 2ns$	$\Delta T_{max}=\pm 5ns$	$\Delta T_{max}=\pm 0.2ns$	$\Delta T_{max}=\pm 1ns$
	$\Delta r_{max}=\pm 5ns$	$\Delta r_{max}=\pm 10ns$	$\Delta r_{max}=\pm 2ns$	$\Delta r_{max}=\pm 5ns$	$\Delta r_{max}=\pm 0.2ns$	$\Delta r_{max}=\pm 1ns$

Table APB.2: Proposed optical pluggable classes.

While such pluggable transceiver accuracy classes are related to node classes, it doesn't mean a class C.x transceiver can only be used in class C nodes. What's important is the intended maximum constant time error contribution of pluggables, to be used in node and link level cTE budgeting. Using more accurate pluggables in a less accurate node class (e.g. Class C.x pluggables in a Class B node) is always possible, and relaxes cTE requirements for the rest of the node. Using less accurate pluggables in a more accurate node class (e.g. Class A.x pluggables in a Class B node) may still be possible if the overall node level cTE budget is still met. It is also allowed for both ends of a link, or both ports of a node, to use pluggables of different classes as long as the end-to-end cTE budget is still met.

It is important to note that for cost reasons, the accuracy class to which a certain pluggable belongs should be guaranteed by design, and compliance to the specs should be ensured during design verification testing (DVT), not during manufacturing verification tests.

For pluggables supporting **multiple bit rates**, the exact configuration of the Tx/Rx signal chain may depend on the bit rate setting. If different operating modes bring significant differences in Tx and Rx propagation delay, all operating modes should be characterized. Different modes might support different accuracy classes and could have different "static" delay values, which should all be represented in the internal EEPROM.

6.1 Structure of the additional EEPROM data content for propagation delay characterization

The data structure in the optical transceiver EEPROM is expected to support the data necessary to estimate propagation delay contributions of the pluggable module and to apply propagation delay compensations for the module. Modules with multiple modes of operation (e.g. multiple bitrates) are expected to allow to deduce the latency values for each mode.

The following data is suggested:

- Number of modes the pluggable module supports.
- Mode currently used by the pluggable module.
- For each supported mode: Typical Tx propagation delay. Typical Rx propagation delay.
 - The suggested range is at least 10 ps to 50 μ s.
- For each supported mode: quasi-static Tx propagation delay, quasi-static Rx propagation delay.
 - The suggested range is at least 10 ps to 100 ns.

6.2 Pluggables propagation delay characterization principles

While it is important to have numbers for propagation delays that can be used for cTE budgeting, it is equally important that the determination of such numbers is not a cost adder for the pluggables. We do not anticipate individual transceiver characterization during volume manufacturing tests will be necessary. The proposed approach to modeling propagation delays should enable a *guaranteed by design* approach, supported by characterization of a statistically significant population of individuals exposed to a variety of corner conditions during the design validation test (DVT) phase.

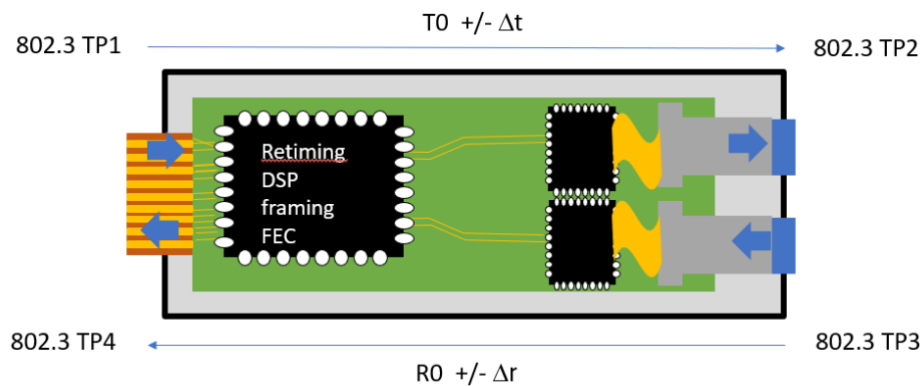

Figure APB.10: measurement points.

Propagation delay in Tx will be measured between the electrical pluggable input and the optical Tx connector output; using the nomenclature of IEEE 802.3, between test points TP1 and TP2. Propagation delay in Rx will be measured between the optical Rx connector input and the electrical pluggable output using the nomenclature of IEEE 802.3, between test points TP3 and TP4. Repeating these basic measurements over a significant number of units, exposed to corner combinations in terms of voltage, case temperature, unit's soft and hard restarts, fiber connection/disconnection events, it will be possible to create distribution histograms of the measured values.

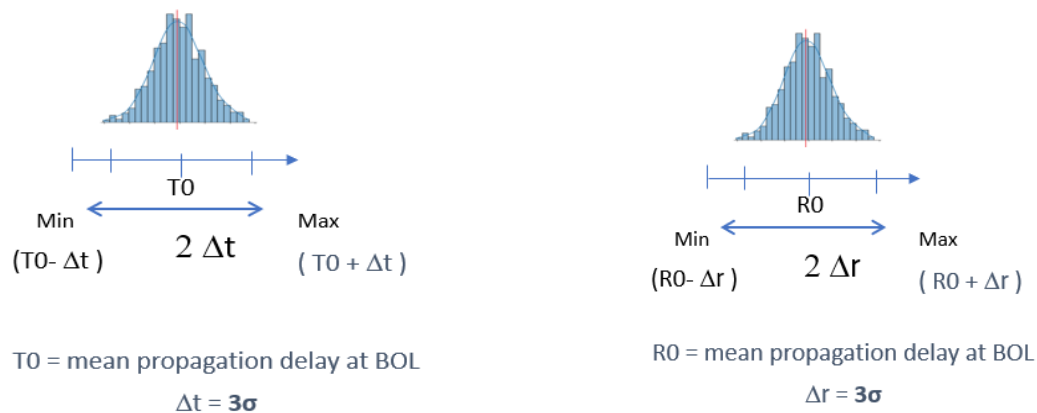

Figure APB.11: histogram measurements

The "typical" propagation delays for Tx and Rx will be the mean values of both distributions. The "quasi static" part will be set at three standard deviations from the mean value. These four values for each supported bit rate, determined during DVT, will then be written in the internal EEPROM map of all the individual transceivers belonging to that design generation, as described in 6.1.

7. An example of link cTE budgeting

Pluggables are just a part of a node/link, and the overall cTE at system level also depends on the optical infrastructure and the hosts. Therefore, it may be possible to meet the intended cTE limit for a given application *with different allocations of cTE to the different contributors*.

The following figure illustrates the different contributions of a given link between two nodes to the end-end cTE. Nodes A and B have a link composed of module i on Node A, module j on Node B, and interconnecting fiber. (For completeness, the contributions to cTE can also be considered at Node level as shown at the bottom of the figure).

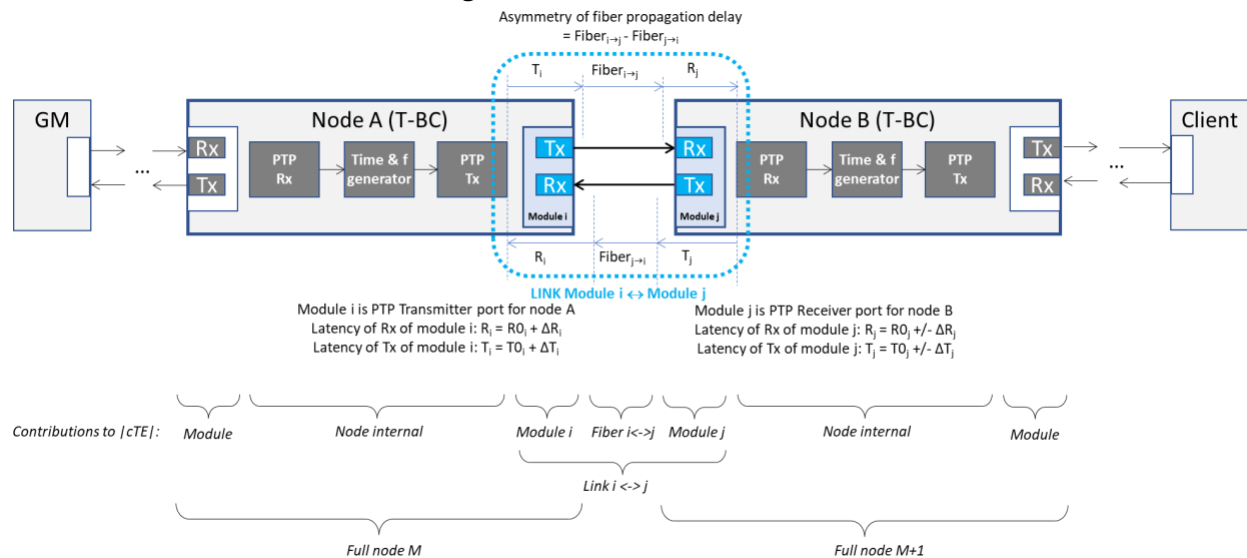
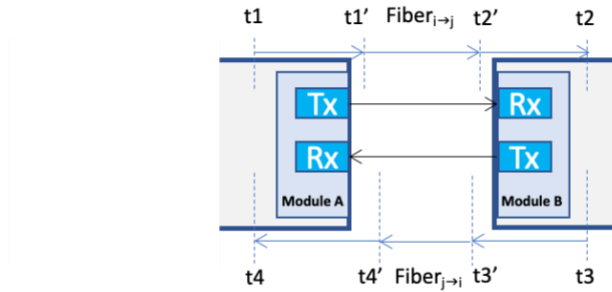

Figure APB.12: Different propagation delay contributions to end-to-end cTE.

The typical values R_0 , T_0 of both modules are known and can be compensated for in their respective PTP functions, as described in IEEE 1588 [PTP]. In case the optical interconnection between i and j is also known (fiber distance, fiber type, wavelengths used by the Tx of modules i and j) the fiber propagation asymmetry can be deduced and can also be compensated for at the PTP receiver side. The compensated values t_1' , t_2' , t_3' , t_4' are then used in the PTP process.

Fiber propagation asymmetry = $Fiber_{i \rightarrow j} - Fiber_{j \rightarrow i}$



Compensations in Node A:

$$t1' = t1 + TO_i$$

$$t4' = t4 - RO_i$$

Compensations in Node B:

$$t1' = t1$$

$$t2' = t2 - RO_j$$

$$t3' = t3 + TO_j$$

$$t4' = t4$$

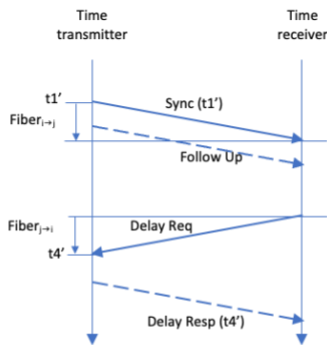

$$\rightarrow \text{Delay for PTP Rx in Node B} = \frac{1}{2} ((t2' - t1') + (t4' - t3'))$$

Additionally, the Delay can be compensated for known fiber asymmetry.

Figure APB.13: Propagation delay compensation in nodes across a link.

The remaining contribution to cTE of the link $i \leftrightarrow j$ is composed of the unknown (and hence uncompensated) asymmetries of modules i and j , and the fiber propagation in case the optical interconnection is not known (e.g. unknown fiber distance):

$$\pm \frac{1}{2} [\text{max asymmetry}_i + \text{max asymmetry}_j (+ \text{max asymmetry}_{\text{fiber}} \text{ if unknown})]$$

With the module asymmetries determined by their respective Class;

Module i Class => $\text{max asymmetry}_i = \Delta T_{\text{max}_i} + \Delta R_{\text{max}_i}$

Module j Class => $\text{max asymmetry}_j = \Delta T_{\text{max}_j} + \Delta R_{\text{max}_j}$

8. Classes for TDM-PON optics

For **TDM-PON OLT and ONU pluggables** the asymmetry in up- and down-stream directions is allowed. The ranging process for basic ONU operation takes the round-trip delay into account. But unknown contributions to cTE in each direction must be limited to reduce the inaccuracy of the ToD deduction in the ONU. A similar classification as above can be taken for TDM-PON pluggables. Note that PON systems are modeled as a pair of media converters in G.8271.1. The whole PON system includes OLT uplink optics, OLT node, OLT PON optics, Optical Distribution Network (ODN), ONU PON optics, ONU node, and ONU UNI optics.

For consistency the contribution to cTE by the OLT PON optics and ONU PON optics (together with the ODN forming a PON link) can follow the same classification designation as for point-point optics.

9. References

[PTP] IEEE 1588-2019 "IEEE Standard for a Precision Clock Synchronization Protocol for Networked Measurement and Control Systems", 2020-06-16

Annex A: 50 Gb/s xWDM 15 km LLS blueprint

1. Implementations under study

Different implementations for 50 Gb/s WDM are currently under study keeping in mind network requirements widely described in this paper:

- Maximum distance of 15 km to accommodate the same requirement used for lower data rates and current infrastructure.
- SFP56 is the preferred form factor as it is beneficial to keep the same mechanical dimensions as lower data-rate transceivers.
- As described in chapter 6.1 “I-temp” operating temperature range and low power consumption are very important.

Since technologies are already available in the market and employed in gray optics, 25 GBaud PAM4 modulation format appears to be the most reasonable choice.

The increasing data rate makes it very challenging to meet the required performance so to fulfill these needs, different options are under evaluation to meet the insertion loss budget requirement and reduce chromatic dispersion impairments.

To have acceptable dispersion penalties, O-band could be adopted. It is generally known that O-band has a risk of FWM (Four Wave Mixing), especially when the wavelengths are closer to the zero-dispersion wavelength of the fiber (1310 nm typ.¹⁰) and the grids are denser, but theoretically FWM can be managed by operating far enough from the zero-dispersion wavelength. Another thing to consider is that longer wavelengths distant from zero-dispersion, such as 1370 nm, has disadvantage in dispersion. Optimum wavelength grids, such as 1320 nm to 1350 nm, are under study.

In C-band, the dispersion penalty is a big challenge for 15 km distances at high data rates. One way to overcome this challenge is to implement dispersion compensation methods like DCM (dispersion compensation modules – e.g. based on dispersion compensation fiber or fiber Bragg gratings), EDC (electronic dispersion compensation) at the receiver, signal predistortion at the transmitter, ODC (optical dispersion compensation) at transmitter or receiver by means of photonic integrated circuits (PICs) or the use of modulation formats resilient to chromatic dispersion (duobinary and its extension: Combined Amplitude and Phase Shift keying (CAPS), Differential Quadrature Shift Keying (DQPSK)). All these techniques have their pros and cons, as discussed in [4] and [5], and further evaluation is needed to understand the most suitable one.

On the other hand, Coherent solution in C-band is sufficient to overcome the dispersion challenge with no risk of FWM. As is commonly known, this solution also enables higher data rates such as 100 Gb/s, which will likely be a necessary data rate in LLS link in the future. In this case, however, since DSP is indispensable for the implementation, power consumption of the 100G Coherent pluggable

¹⁰ Rec. ITU-T G.652 (11/2016) states in Tables 1 and 2 that the zero-dispersion wavelength is between 1300-1324 nm.

module is assumed to be 6W in QSFP28 form factor over I-temp range at present (see section 6.1, Table 2). This is a major challenge to be addressed in order to adopted for radio units. It is also challenging to incorporate all the necessary components into SFP56 form factor. Also due to DSP, latency is another possible major challenge which needs to be carefully evaluated especially for use in LLS link. (see Appendix B “Optical pluggable performance for tight synchronization”).

2. Candidates of wavelength grid in O-band vs Four-wave mixing penalties

In order to assess the possible penalties deriving from Four Wave Mixing (FWM) for O-band WDM, a simplified analytical model derived from [1], [2] and [3] has been used for simulations. FWM penalties are known to get worse with low amount of chromatic dispersion, close spacing of wavelengths, high power per wavelength launched into fiber [2,3]. In order to estimate the order of magnitude of such penalties, we have used three scenarios, which are listed and illustrated below:

- 1) A “baseline” scenario, considering 12 wavelengths with 800GHz spacing on the LAN-WDM grid.
- 2) An “overlay” upgrade scenario, in which 3x100GHz DWDM wavelengths are injected into each of the 12 LAN-WDM filter slots of the “baseline” scenario.
- 3) An “expansion” upgrade scenario, in which the original 12 x 800GHz LAN-WDM wavelengths of the “baseline” scenario are not touched but 48 new wavelengths, with 100GHz spacing on the DWDM grid are added right above of the LAN-WDM region (>1322nm).

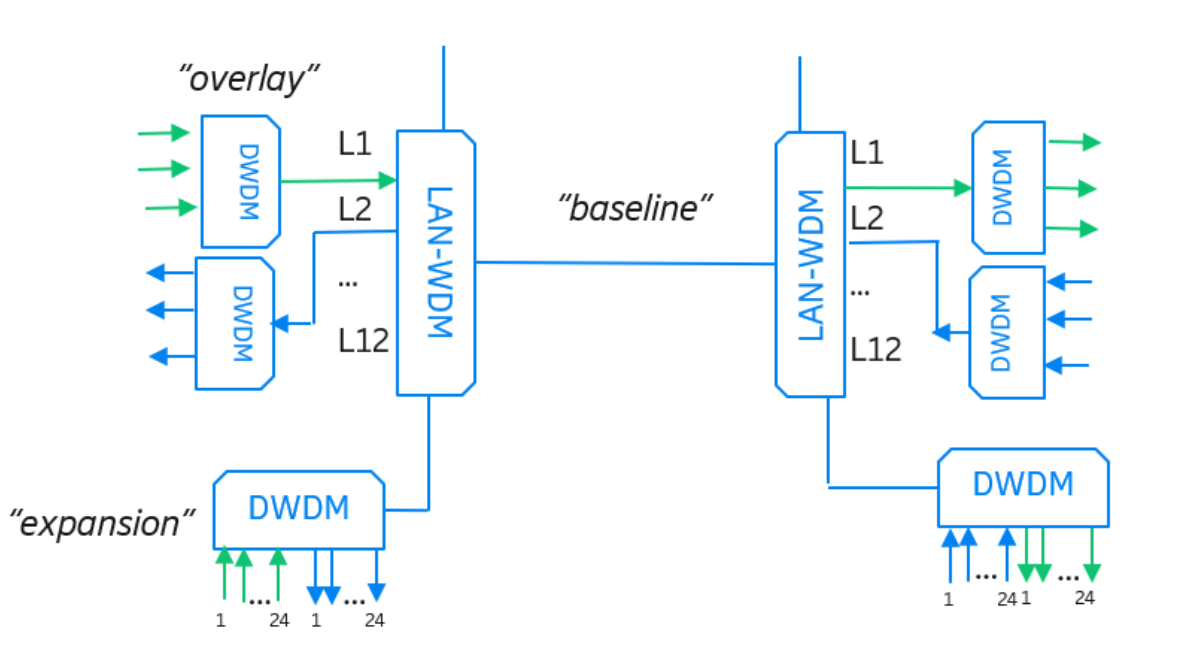

Figure ANA.1: “baseline”, “overlay” and “expansion” scenarios.

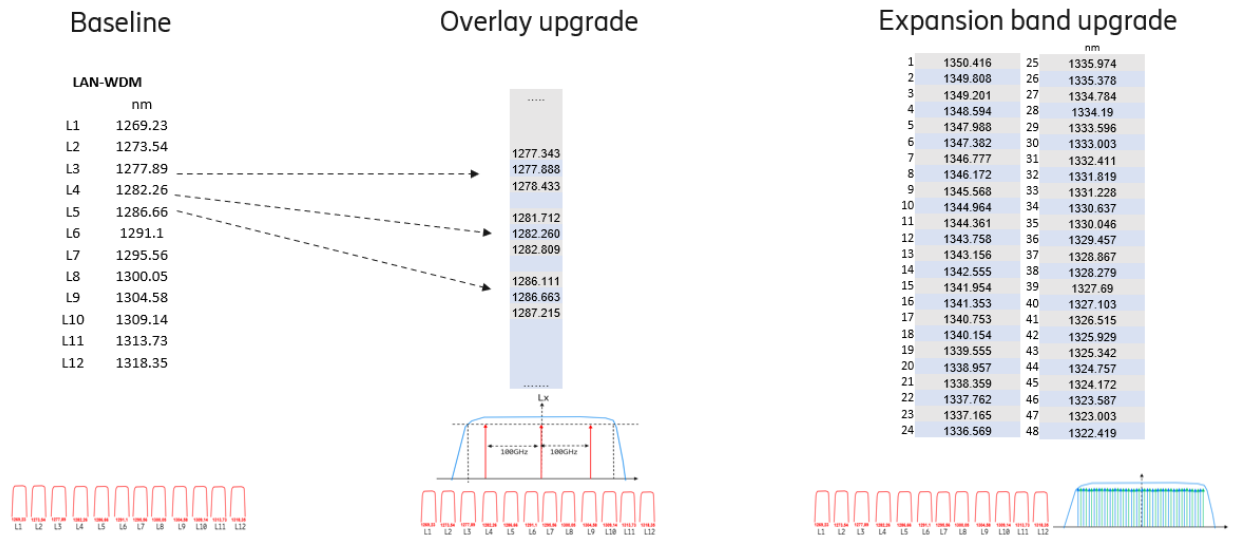

Figure ANA.2: "baseline", "overlay" and "expansion" wavelength grids.

The simulation calculates the OSXR (optical signal to nonlinear crosstalk ratio) in a worst-case condition, assuming corner conditions with all FWM penalties coinciding:

- maximum transceiver output power and minimum optical filter losses,
 - These conditions result in a +2 dBm launch power per channel after WDM filters,
- nominal fiber distance of 15km (for max cumulative effect),
- exact polarization match of all transmitters,
- fixed spacing wavelength grids,
- channels exactly on the nominal wavelength.

A sweep of the optical fiber "zero dispersion" wavelength, in the allowed variation range dictated by ITU-T G.652 [G.652], is performed in order to exacerbate all possible 'resonance' conditions between the signal wavelength grid and the specific zero-dispersion wavelength value. Once OSXR is obtained, it can then be translated into BER under the simplifying assumption that crosstalk noise behaves as additive Gaussian noise. Then, assuming the target BER is 5E-5 (Reed-Solomon "KR" pre-FEC threshold), the FWM penalty in dB can be estimated. These simulations are shown in the figures below:

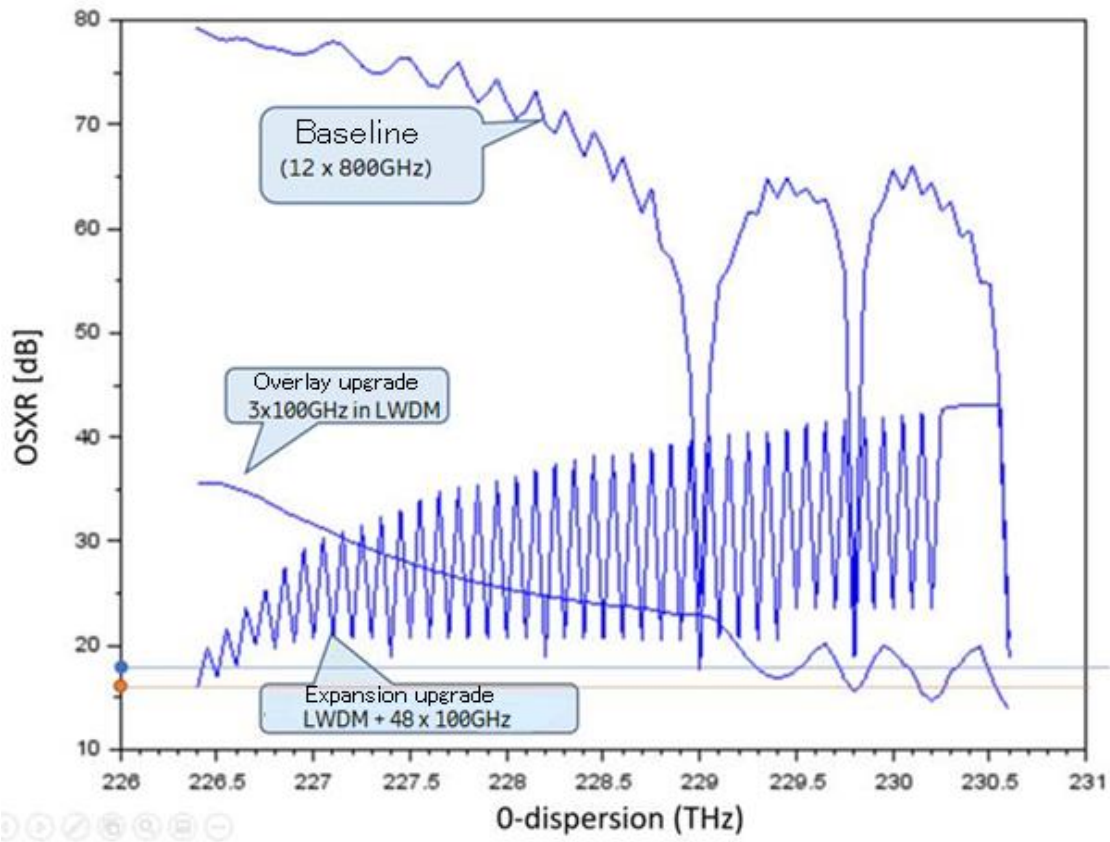
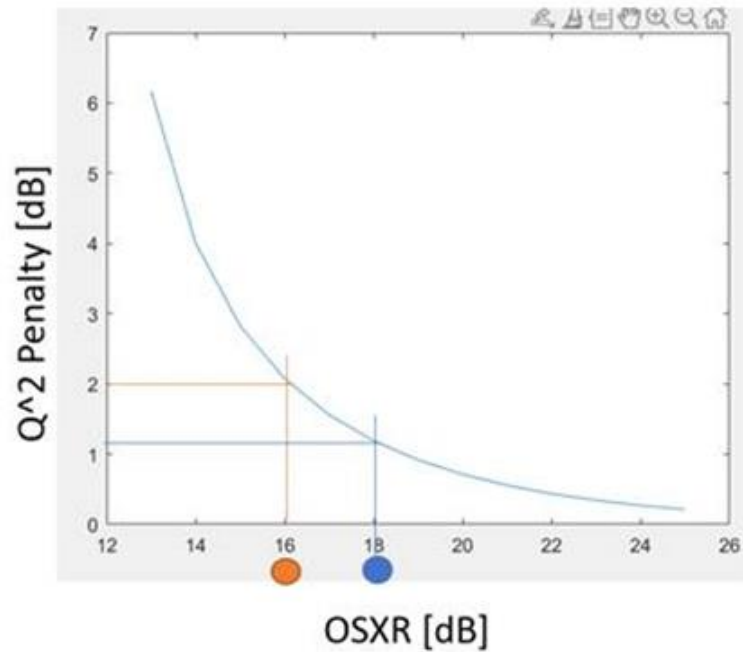

Figure ANA.3: OSXR results obtained by sweeping the zero-dispersion wavelength all over the allowed range, for the three considered scenarios.



```

BER=5e-5;
Q0=(1.4142*erfcinv(2*BER));
OSXR=[13:1:25];
Qfwm=10.^(OSXR/20);

Qpen=-10*log10(1-Q0^2./(Qfwm.^2))

```

Figure ANA.4: OSXR to penalty conversion under the assumption of additive Gaussian crosstalk noise.

As is shown in the figures above, for the “baseline” 12 x 800GHz LAN-WDM system, there are three “notches” in correspondence of specific values for zero-dispersion fiber wavelengths “resonating” with the fixed grid, which brings the OSXR close to 18dB, corresponding to 1dB penalty.

For the system in the “overlay” scenario, the combination of denser spacing (100GHz) with relative vicinity to the region in which zero-dispersion fiber wavelength is swept brings OSXR to be lower than 16dB in the worst case.

For the system in the “expansion” scenario, the effect of denser spacing is de-potentiated by the fact signal wavelengths are far from than the zero-dispersion fiber wavelength range, and the worst case OSXR is again close to 18dB.

These simulation results show a safe worst-case objective for FWM effects in the “baseline” and “expansion” scenarios could be 18dB OSNR, corresponding to a FWM penalty of about 1dB @ BER=5E-5. It should be noted that the simulation conditions are extremely unrealistic, as it in the real world is very unlikely that all the possible corner conditions will combine in the most unfavorable way. It should also be noted that this worst-case penalty of 1dB could be further mitigated by putting a cap on the maximum output power of transceivers. The effect of launched

power is more than linear, so each dB of reduction in Tx power is expected to bring a 2dB improvement of OSXR.

Summarizing findings: LAN-WDM with its wide spacing does not pose FWM penalty concerns; 100GHz DWDM grids in the LAN-WDM wavelength region would be impacted more severely by FWM; 100GHz grids at wavelengths above 1322nm does not appear to pose FWM penalty concerns, thanks to the beneficial effect of residual chromatic dispersion.

3. Preliminary Blueprint

Whatever the solution will be, per-channel flexibility and adaptability to different values of links chromatic dispersion mitigation will be required in order to be adopted in the mobile application. Moreover, as already mentioned, implementation in a widespread pluggable format like SFP56 and reuse of mature technology like PAM4 are preferred, provided it is possible to fit the performance parameters specified in the following.

To limit loss budget constraints, an option is to carefully reconsider the number of channels and filter requirements.

The following table shows the preliminary estimates of required loss budgets for C-band and O-band to support 15 km:

	Fiber Attenuation	Connectors Insertion Loss	Maintenance Margin	Mux/DeMux Insertion Loss	Total Loss budget
C-band DWDM 48ch	3.8 dB *	2 dB *	1 dB *	9 dB (2 x 4.5 dB)	15.8 dB
O-band DWDM 48ch	6.0 dB *	2 dB *	1 dB *	9 dB (2 x 4.5 dB)	18.0 dB

Table ANA.1: Preliminary Loss budget estimations for C-band DWDM and O-band DWDM. * Using the values of Table 4 in Section 6.9.

DSP-based pluggable modules are increasingly attractive for mobile applications while this function introduce higher latency, costs and power consumption.

Analog CDR-based solution is beneficial in terms of power consumption and latency. How much loss budget can be achieved by CDR is under study.

The table below summarizes a preliminary 15 km xWDM 50 Gb/s LLS blueprint:

Typical use cases	15 km RU-DU, passive DWDM over a single fiber Blueprint (chapter 8.2.3) 15 km RU-DU, passive DWDM bus over a single fiber Blueprint (chapter 8.2.4) 15 km RU-DU, semi-active DWDM bus over a single fiber Blueprint (chapter 8.2.5)
Distance	Typ Min 0 km; Typ. Max: 15 km
Channel Insertion Loss	18 dB in O-band, 15.8 dB in C-band (under study)
Chromatic Dispersion	< 65 ps/nm @ 1350nm * (< 270 ps/nm @ C-band**)
Mode, Nr ch., Wavelengths	Dual fiber pluggables, single fiber trunk: 48 wavelengths @ 100 GHz spacing
Temp. Range/Class	I-temp
Lifespan	15 years
Data rates	50 Gb/s
Formfactor	SFP56
FEC, Mod format	yes, PAM4 (likely)
Power Class	Under study (PC4 / 2.5 W preferred, but 3.0W appears to be more reasonable target for tunable solutions)
Pluggables codes	50G-15Km-?-?-48-2-SFP56
Key technologies	Low-cost 50Gb/s EML DWDM without wavelength lockers, APD. Athermal AWG or TFF filters
Standards	No

Table ANA.2: Preliminary 15 km xWDM 50 Gb/s LLS blueprint. () 1350nm is a preliminary example of the possible longest wavelength to be adopted with an aim to limit FWM effect. The chromatic dispersion for 1350 nm is calculated by " $S_{omax}/4*L*(\lambda-\lambda_{omin}^4/\lambda^3)$ ", where S_{omax} is the maximum zero dispersion slope (0.092 ps/nm²/km), L is the maximum fiber length (15 km), λ_{omin} is the minimum zero dispersion wavelength (1300 nm), λ is 1350nm. "4 ps/(nm*km)" described in Section 6.9 is not used here because 1350 nm is distant from the typical wavelength of O-band. (**) This dispersion has to be compensated by DCM in fiber link or EDC in pluggable module, etc., which requires further evaluation.*

4. References

[1] "FWM simulations in O-band", Dora van Veen & Vincent Houtsma, Nokia Bell Labs – contribution to the P802.3ca IEEE Task Force:

https://www.ieee802.org/3/ca/public/meeting_archive/2016/07/van_veen_3ca_1_0716.pdf

[2] N. Shibata, R. P. Braun, and R. G. Waarts, "Phase-mismatch dependence of efficiency of wave generation through four-wave mixing in a singlemode optical fiber," IEEE J. Quantum Electron., vol. 7, pp. 1205-1210, July 1987.

[3] K. Inoue, "Four-wave mixing in an optical fiber in the zero-dispersion wavelength region," J. Lightwave Technol., vol. 10, pp. 1553-1561, Nov. 1992.



[4] E. Forestieri, M. Secondini, L. Potì and F. Cavaliere, "High-Speed Optical Communications Systems for Future WDM Centralized Radio Access Networks," in *Journal of Lightwave Technology*, vol. 40, no. 2, pp. 368-378, 15 Jan.15, 2022, doi: 10.1109/JLT.2021.3131399.

[5] P. Iovanna et al., "Optical Components for Transport Network Enabling The Path to 6G," in *Journal of Lightwave Technology*, vol. 40, no. 2, pp. 527-537, 15 Jan.15, 2022, doi: 10.1109/JLT.2021.3117122.



Annex B: Remote optical module management

1. Description of the application

This annex proposes and describes a messaging channel, a frame structure, a memory map, and a protocol that together enable the management of optical modules at the two ends of an optical “black link”, either WDM or gray and single or dual fiber. The mechanism reuses the head-to-tail message channel (HTMC) defined in ITU-T rec. G.698.4 with focus on remote performance monitoring also called Remote DDMI.

In the tunable DWDM case, the requirement for end-to-end operation of the messaging channel is that the two module transmitters are tuned to the correct wavelength(s) so that messages sent by one module’s transmitter will be received at the receiver port of the other module.

As shown in Figure ANB.1, optical transceivers at both ends of the optical link are equipped to send and receive messages to and from the other end. The messages are transmitted over a low frequency, low modulation depth amplitude modulated channel on top of high-speed digital data (see Figure ANB.1).

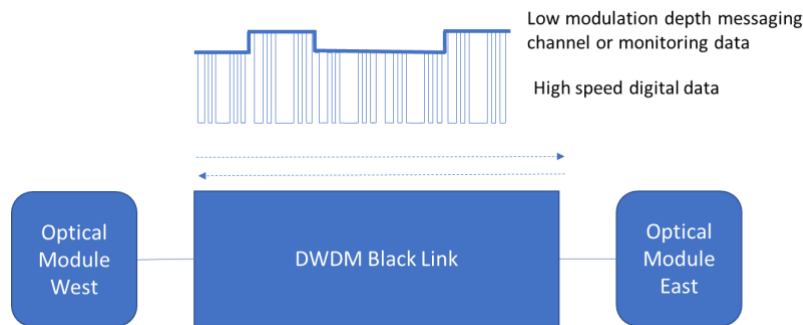

Figure ANB.1: Optical modules exchanging messaging channel and monitoring data over a DWDM black link¹¹ (as an example).

Unless otherwise specified, the messaging channel is assumed to be generated by the optical module and not by the host system. Similarly, the specified protocols (“state machines”) are assumed to run in the module and not in the host system. This makes it desirable to specify the same behavior for the transceivers at both ends of the link.

There are situations where HEE (head-end equipment) (e.g., a DU) may send control messages to transceivers at the TEE (tail-end equipment) (e.g., a RU) or may request data from the TEE transceiver’s memory. This scenario is illustrated in Figure ANB.2.

¹¹ The term “black link” means that the internal details of the link are not defined here.

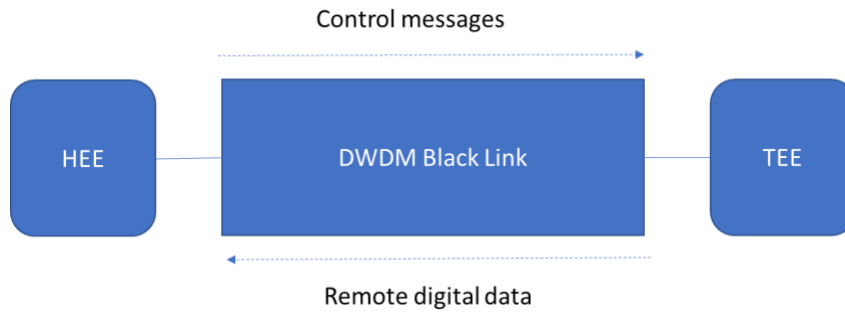

Figure ANB.2: WDM black link example with HEE and TEE

2. Message channel characteristics

The message channel is a low-frequency, low modulation-index channel on top of the regular NRZ data. It is based on the message channel defined in ITU-T G.698.4 [G.694.4]. By keeping the modulation index low, below 10%, the receiver sensitivity penalty due to the message channel can be kept to less than 1 dB. The exact signaling rate and tolerance are currently under study. Issues include the potential impact on EDFAs (erbium-doped fiber amplifier) if used in the network, and overall message throughput being adequate.

Parameter	Range	Unit
Signaling rate (-40 to 85°C)	5 kb/s +/- 5%	kb/s
Signaling rate tolerance	100,000	Ppm
Modulation index	0 to 10	%
Modulation format	2-level Manchester code	

Table ANB.1: Message channel characteristics

3. Frame structure and message types

Messages are organized into 48-bit frames as specified by ITU-T Recommendation G.698.4:

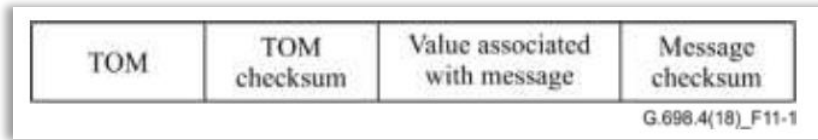

Figure ANB.3: ITU-T Rec. G.698.4 message frame format

TOM value (11-bit field)	Message type	Message content (24-bit)
0x000 to 0x00B	Used by G.698.4 for frequency tuning	
0x2A0	Command and Response	Send command and respond message
0x2A1	Retransmission	Requesting message retries
0x2A2-0x2A7	Reserved	Reserved
0x2A8	Sending page data content	Send A0h and vendor page data
0x2A9	Sending page data content	Send A2h and reserved page data
0x2AA	Extended Idle	A 24-bit running counter.
0x2AB-0x2AF	Reserved	Reserved

Table ANB.2: New Message types (TOM) used for Remote Performance Monitoring

4. SFP memory pages and registers

To support the messaging channel and remote DDMI, several new registers are added to the existing SFF-8472 / SFF-8690 [SFF8690] standard locations. These registers are added to A2h pages 02h (support registers) and A2h pages 20h to 24h (mapped remote pages). Host software communicates messages to the remote device through these registers.

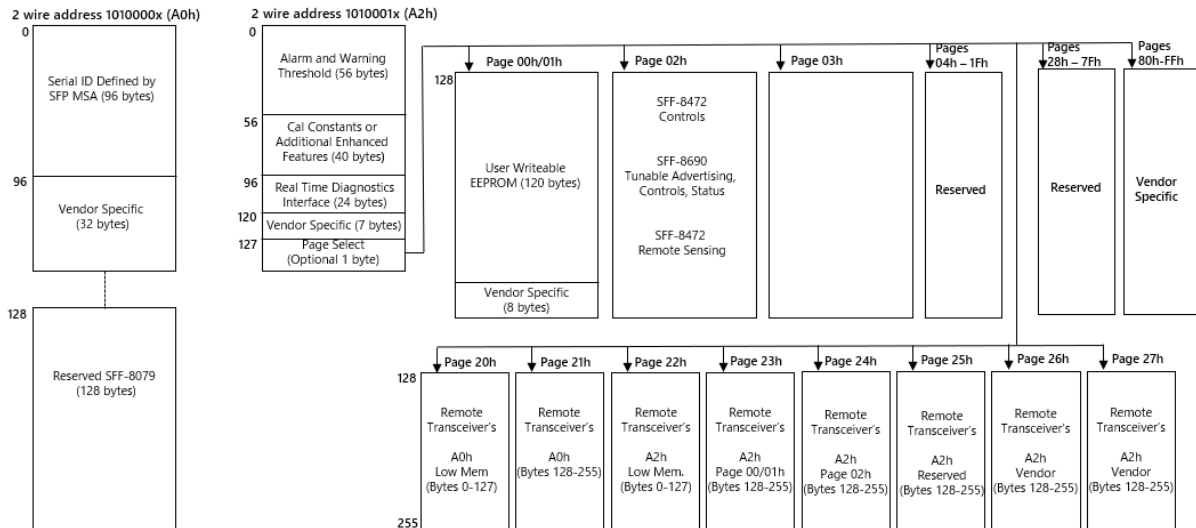

Figure ANB.4: SFF-8472 Memory Organization showing register locations for Remote transceiver.

Data received from the remote device is stored in up to 5 new pages at A2h pages 20h to 24h, with another 3 pages, 25h to 27h proposed for future and vendor specific use. The mapping between the remote device pages and these locations are given in Table ANB.3. Proposed new registers and their locations are listed in Table ANB.4.

A2h upper page (host)	Remote page
20h	A0h, lower
21h	A0h, upper
22h	A2h, lower
23h	A2h, upper 00/01h
24h	A2h, upper 02h
25h to 27h (optional)	Vendor specific

Table ANB.3: Mapping from remote device pages to new pages at the local (host) device.

A2h Address Bytes	Function	Description
192-197	Status/Debug	Clock Status and Debug
198-207	Error Counters	Return frame error counters, enables calculation of BER or FER
208-210	Tx Remote Cmd	Allow remote memory map to be written.
211	Tx Mod Index	Modulation Index
212-215	Reserved	Reserved
216-231	Reserved	Reserved for Alarm Bit Mask of frames.
232-255	Reserved	Reserved

Table ANB4. Page 02h Register Summary for Remote Performance Monitoring. Note: The mapping of registers 198-207 in A2 high allows the HEE to monitor the remote sense Rx channel error rates. The HEE can request this error rate information and can adjust the Tx modulation index to reduce the error rate.

5. Operations enabled by the message channel

5.1 The value and standardization of remote monitoring and management of optical modules

As described above, adding a message channel and the necessary firmware to SFP transceivers enables management and monitoring of remote transceivers. For 5G front-haul line systems this means that the host software at the HEE can send commands and request data from individual transceivers at the TEE / RRU site. The technique is generic and can be applied to modules attached to a gray link.

Since the transceivers at the TEE may be from different vendors, installed at different times, potentially by different organizations, multi-vendor interoperability is important. Standards development organizations (SDOs) such as ITU-T SG15 have a role to play in doing the work to publish recommendations for the industry. Typically, those recommendations are published once the industry has agreed on a set of specifications through activities such as company specific specifications, alliances such as MOPA, and various MSAs such as the Smart Tunable MSA [SmartT].

5.2 Proposed remote-DDMI method

There is a common state machine inside the modules at both ends of the link. Under host system control, one end of the link is activated as the HEE and will be the module that requests remote DDMI data from the TEE module. The detailed state diagram is currently in development in the industry and is planned to be standardized in a relevant standards group.

5.3 Autonomous module tuning

The Smart Tunable MSA has published a specification for self-tuning of transceivers when they are first plugged into the network, or when a module reset is performed. Self-tuning is fully autonomous because channel isolation components (Mux/Demux) restrict messages received to just those sent on a particular frequency. Like the remote-DDMI methods described here,

multiple vendor's tunable modules comply with the self-tuning specification through firmware methods.

5.4 Proposed remote tuning method

In cases where the modules used do not have autonomous tuning capabilities, it is possible to use the messaging channel for remote tuning. If the remote modules comply with SFF-8690 [SFF8690] they will initialize to a default transmit frequency stored in A2h bytes 146-147. However, unless the Tx of the remote device is connected to the correct Mux port, it will not be able to join the network until it is reprogrammed to the correct frequency. This is achieved by having host software and SFP firmware that implements the state diagram discussed above.

6. References

- [G.694.4] ITU-T Rec. [G.694.4 "Multichannel bi-directional DWDM applications with port agnostic single-channel optical interfaces", March 2018
- [SFF8690] SFF-8690 "Tunable SFP+ Memory Map for ITU Frequencies", January 2013, (<https://www.snia.org/technology-communities/sff/specifications>)
- [SmartT] smarttunable-msa.org